

Mata le Chéile

5

Florence Gavin

Colmán Ó Drisceoil
a d'aistrigh

 AN GÚM

Baile Átha Cliath

An leagan Béarla

Ba iad Mulberry Publications a chéadfhoilsigh faoin teideal *Maths Together: Five*

© Florence Gavin, 1999

An Dara hEagrán 2002

An leagan Gaeilge

© Foras na Gaeilge, 2006

ISBN 978-1-85791-546-4

Gach ceart ar cosaint. Ní ceadmhach aon chuid den fhoilseachán seo a atáirgeadh,
gan cead a fháil roimh ré ón bhfoilsitheoir.

Tá cead ón bhfoilsitheoir ag múinteoirí, áfach, fótachóipeanna a dhéanamh
de leathanaigh lena n-úsáid sa seomra ranga.

Mulberry Publications Teo. a chuir suas an cló

Printset & Design Teo. a chlóbhuail in Éirinn

Le fáil ar an bpost uathu seo:

An Siopa Leabhar,
6 Sráid Fhearchair,
Baile Átha Cliath 2.
ansiopaleabhar@eircom.net

nó

An Ceathrú Póilí,
Cultúrlann Mac Adam–Ó Fiaich,
216 Bóthar na bhFál,
Béal Feirste BT12 6AH.
leabhair@an4poili.com

Orduithe ó leabhardhioltóirí chuig:

Áis,
31 Sráid na bhFíníní,
Baile Átha Cliath 2.
eolas@forasnagaeilge.ie

An Gúm, 24-27 Sráid Fhreidric Thuaidh, Baile Átha Cliath 1

Réamhrá

Is é cuspóir *Mata le Chéile 5* cur le tuiscint na ndaltaí ar na príomhchoincheapa atá leagtha amach in *Curaclam na Bunscoile: Matamaitic* (An Roinn Oideachais agus Eolaíochta, 1999). An obair phraiticiúil atá ar fáil sa phacáiste seo, cuirfidh sí le heolas na ndaltaí ar an Matamaitic agus tabharfaidh sí deis dóibh teanga na Matamaitice a fhoghlaim agus a úsáid go beacht.

Déantar coincheapa na Matamaitice a fhorbairt de réir a chéile sa phacáiste seo. Tá deis ag daltaí dá réir sin a gcuid scileanna a fhorbairt de réir a chéile, ar luas a oireann dóibh féin. D'fhéadfaí *Mata le Chéile* a úsáid le rang iomlán, le grúpa daltaí nó le daltaí aonair. D'fhéadfadh codanna éagsúla den phacáiste a bheith in úsáid ag aon am amháin san aon rang amháin, ag brath ar chumas na ndaltaí. Ós ceadmhach leathanaigh *Mata le Chéile* a chóipeáil is féidir leis an múinteoir na coincheapa agus na scileanna a chur i láthair, agus dul siar orthu, ar an gcaoi is fearr a oireann do chumas agus d'fhorbairt na ndaltaí ina rang féin. Bíonn daltaí ann a fhoghlaimíonn coincheapa agus scileanna na Matamaitice go gasta ach is beag dalta a fhoghlaimíonn iad gan dul siar go rialta orthu.

Cuirtear béim ar leith sa churaclam nua ar fhorbairt scileanna teanga. Bíonn béim freisin ar théarmaíocht na Matamaitice a fhoghlaim in éineacht leis na coincheapa agus leis na scileanna. Dá ainneoin sin, áfach, gearradh siar ar an léitheoireacht a oiread agus a d'fhéadfaí sa phacáiste seo sa chaoi is gur féidir leis an múinteoir féin díriú ar fhorbairt na scileanna teanga. Tá go leor leathanach sa phacáiste a chabhróidh go mór leis an múinteoir caint agus plé a spreagadh sa rang má chuirtear i láthair an ranga ar an mbealach cuí iad. Tá leathnaigh eile ann a oireann don obair fhorbartha agus athneartaithe a leanfadh an chéadchur i láthair.

Is gá timpeallacht 'shaibhir' thacúil a chur ar fáil sa seomra ranga má tá suim na ndaltaí sa Mhatamaitic le múscailt agus le cothú. Ós rud nach sa chóipleabhar foirmiúil a dhéantar obair *Mata le Chéile* moltar do na múinteoirí obair na ndaltaí a chur ar taispeántas sa seomra ranga. Má bhíonn teacht ag daltaí ar a gcuid oibre ar an gcaoi sin, agus má bhíonn taispeántas leanúnach ar fáil acu de na coincheapa agus de na scileanna atá le foghlaim, beidh siad ag cur lena dtuiscint ar na snáithaonaid éagsúla sa siollabas i rith an ama.

Tá sraith de thrialacha i gcúl an leabhair a chabhróidh le múinteoirí tabhairt faoin measúnú neamhfhoirmiúil a mholtar sna *Treoirlínte do Mhúinteoirí* (lch 19) agus in *Curaclam na Bunscoile: Matamaitic* (lgh 121-25).

Florence Gavin
Iúil 2006

Caibidil	Teideal	Snáithe	Snáithaonad
1	Corruimhreacha & Ré-uimhreacha	Uimhreas	Teoiric Uimhris
2	Roinnt Fhada	Uimhreas	Teoiric Uimhris
3	Seichimh & Fachtóirí	Uimhreas	Teoiric Uimhris
4	Codáin	Uimhreas	Codáin
5	Achar & Imlíne	Tomhais	Achar & Fad
6	Uillinneacha & Línte	Cruth & Spás	Línte & Uillinneacha
7	Meáin	Sonraí	Sonraí a léiriú & a léirmhíniú
8	Codáin Dheachúlacha (1)	Uimhreas	Deachúlacha & Céatadáin
9	Cóimheas	Ailgéabar	Rialacha & Airíonna
10	Céatadáin	Uimhreas	Deachúla & Céatadáin
11	Siméadracht	Cruth & Spás	Cruthanna Déthoiseacha
12	Séana	Uimhreas	Deachúlacha & Céatadáin
13	An tAm	Tomhais	An tAm
14	Codáin Dheachúlacha (2)	Uimhreas	Deachúlacha & Céatadáin
15	Cruth & Spás in 2-T	Cruth & Spás	Cruthanna Déthoiseacha, Línte & Uillinneacha
16	An Ciorcal	Cruth & Spás	Cruthanna Déthoiseacha
17	Scála	Tomhais	Fad
18	Graif & Cairteacha	Sonraí	Sonraí a léiriú & a léirmhíniú
19	Fad	Tomhais	Fad
20	Meáchan	Tomhais	Meáchan
21	Toilleadh	Tomhais	Toilleadh
22	Cruthanna 3-T	Cruth & Spás	Cruthanna Tríthoiseacha
23	Abairtí Matamaiticiúla	Ailgéabar	Cothromóidí
24	Seans	Sonraí	Seans
Aguisín	Teimpléid	Cruth & Spás	Cruthanna Tríthoiseacha
	Trialacha		
	Freagraí		

Corruimhreacha agus Ré-uimhreacha



Corruimhir is ea 7.

Ré-uimhir is ea 6.

Is féidir **ré-uimhreacha** a chur ina dhá shraith chothroma gan aon fuílleach.

① _____ uimhir is ea 8.

② _____ uimhir is ea 9.

③ _____ uimhir is ea 5.

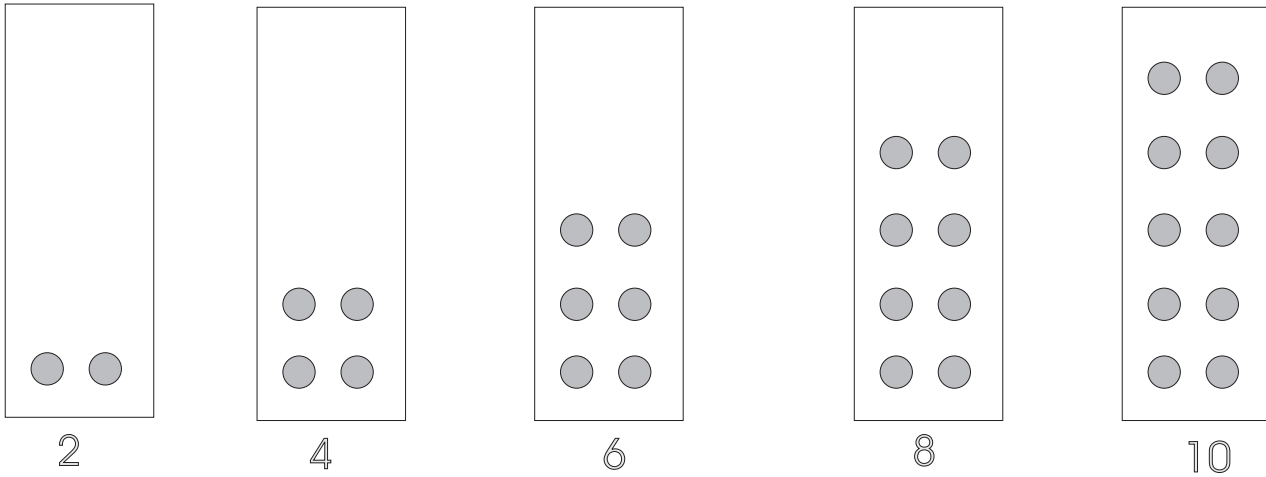

Is ré-uimhreacha iad seo thuas. Tá “páirtí” ag gach ponc.

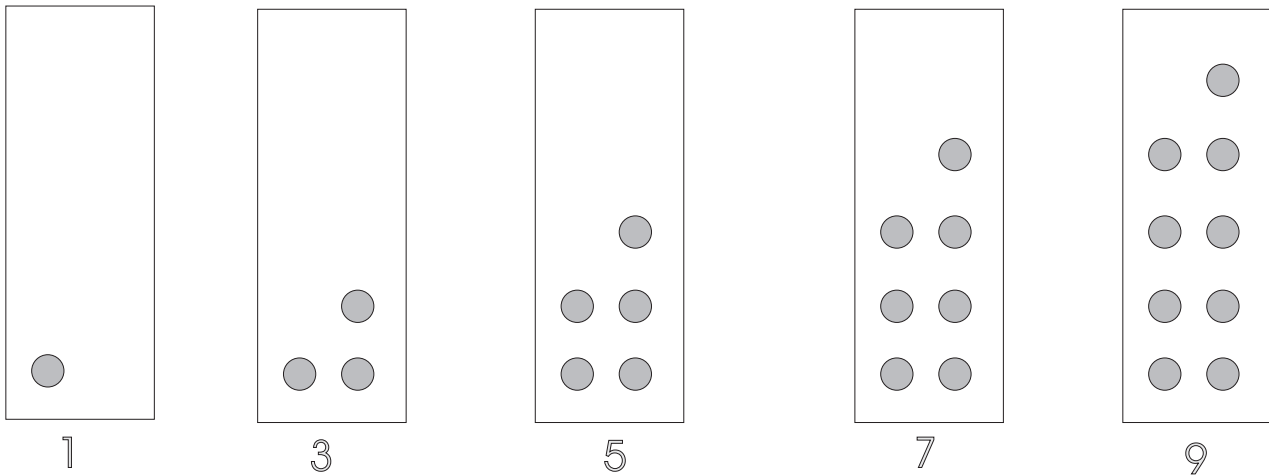

Is corruimhreacha iad seo thuas. Fuílleach 1 a bhíonn ag **corruimhreacha** nuair a roinntear ar 2 iad.

Nuair a chuirimid dhá **chorruimhir** le chéile faighimid **ré-uimhir**.

$$\text{corruimhir} + \text{corruimhir} = \text{ré-uimhir}$$

$$5 + 7 = \square$$

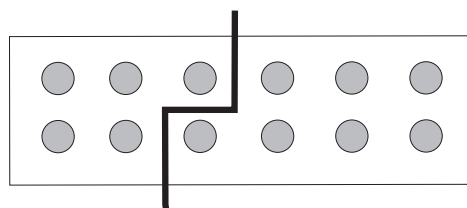

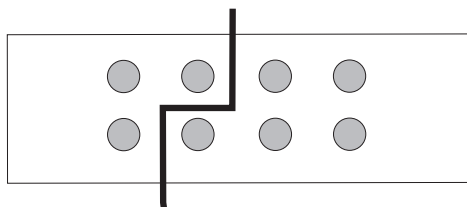

① $3 + \square = \square$

② corruimhir + $\square = \square$

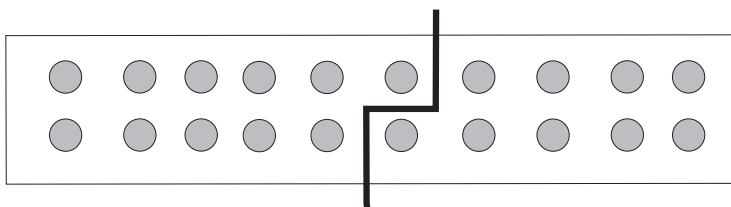

③ $11 + \square = \square$

④ corruimhir + $\square = \square$

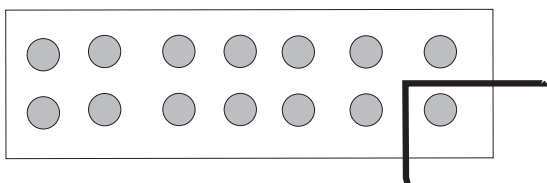

⑤ $13 + \square = \square$

⑥ corruimhir + $\square = \square$

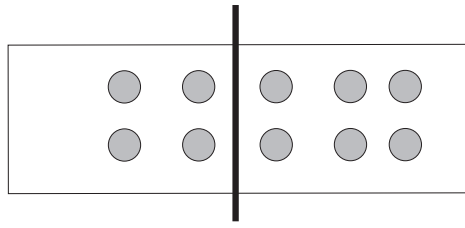

① $4 + \square = \square$

② ré-uimhir + $\square = \square$

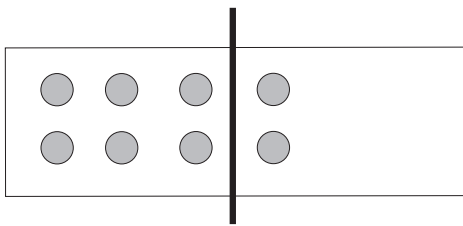

③ $6 + \square = \square$

④ ré-uimhir + $\square = \square$

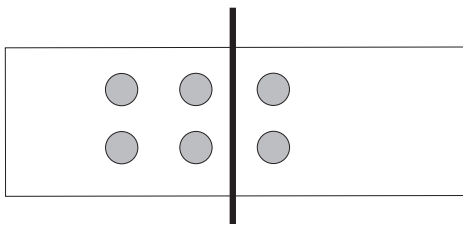

⑤ $4 + \square = \square$

⑥ ré-uimhir + $\square = \square$

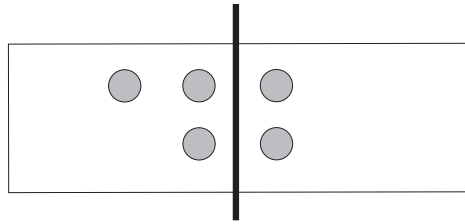

① $3 + 2 = 5$

② corruimhir + ré-uimhir = corruimhir

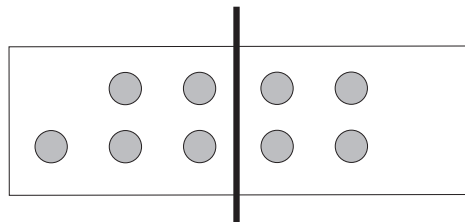

③ $5 + \square = \square$

④ corruimhir + $\square = \square$

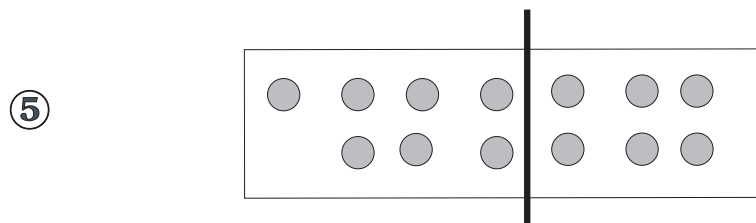

⑤ $\square + \square = \square$

⑥ $\square + \square = \square$

Le foghlaim

Ré-uimhir + Ré-uimhir = Ré-uimhir

Corruimhir + Corruimhir = Ré-uimhir

Corruimhir + Ré-uimhir = Corruimhir

①

Scríobh na chéad trí théarma eile sna seichimh uimhreacha seo a leanas.

(a) 1, 4, 7, 10, _____, _____, _____.

(b) 5, 9, 13, 17, _____, _____, _____.

(c) 31, 28, 25, _____, _____, _____.

(d) $1\frac{1}{2}$, $3\frac{1}{2}$, $5\frac{1}{2}$, _____, _____, _____.

(e) $1\frac{1}{4}$, $2\frac{1}{2}$, $3\frac{3}{4}$, _____, _____, _____.

(f) 25, 50, 75, _____, _____, _____.

(g) $5 \cdot 2$, $6 \cdot 3$, $7 \cdot 4$, _____, _____, _____.

(h) 2, 4, 8, 16, _____, _____, _____.

(i) 2, 3, 2, 6, 2, 9, 2, __, __, __.

Lean an patrún agus líon isteach na boscaí.

$$4 \times 4 = 14 + 2$$

$$4 \times 5 = 16 + 4$$

$$4 \times 6 = 18 + 6$$

$$4 \times 7 = 20 + 8$$

①

$$\square \times \square = \square + \square$$

$$(11 \times 5) - 0 = 55$$

$$(11 \times 6) - 2 = 64$$

$$(11 \times 7) - 4 = 73$$

$$(11 \times 8) - 6 = 82$$

②

$$(a) (\square \times \square) - \square = \square$$

Ná
Dearmad

Ní bhuaileann línte
comhthreomhara
le chéile riamh.

Cuir tic ✓ leis an mbosca ceart.

① Níl aon iolraí ag 6 ar ré-uimhir / corruimhir é mar is ré-uimhir / corruimhir í 6.

② Scríobh iolraithe 6 go dtí 72.

③ An ré-uimhreacha nó corruimhreacha iad go léir?

④ Níl aon iolraí ag 8 ar ré-uimhir / corruimhir é mar is ré-uimhir / corruimhir í 8.

⑤ Scríobh iolraithe 8 go dtí 96.

⑥ An ré-uimhreacha nó corruimhreacha iad go léir?

Is iolraí 2 í uimhir a chríochnaíonn ar 0, 2, 4, 6 nó 8.

e.g. 144

⑦ Liostaigh na hiolraithe go léir atá ag 2 ó 20 go dtí 40.

Is iolraí 5 í uimhir a chríochnaíonn ar 0 nó 5.

e.g. 125

⑧ Liostaigh na hiolraithe go léir atá ag 5 ó 0 go dtí 100.

Roinnt Fhada

Tabhairt Suas agus Garmheastachán a dhéanamh

Déan garmheastachán ar na freagraí: tabhair na huimhreacha go dtí an 10 is gaire.

e.g $61 \div 21$

Tabhair 61 síos go dtí 60.

Tabhair 21 síos go dtí 20.

Is é an garmheastachán atá le déanamh anois ná $60 \div 20$ nó $20 \overline{)60}$ nó cé mhéad uair is féidir liom 20 a bhaint as 60.

$65 \div 21$, $66 \div 21$, $67 \div 21$, $68 \div 21$, $69 \div 21$

Tabhair 65, 66, 67, 68, 69 suas go dtí 70 mar go bhfuil na huimhreacha sin níos gaire do 70 ná do 60. Tá 65 leathbhealach, ach tabhair suas go dtí 70 é.

21 tugtha síos = 20.

Anois déan garmheastachán orthu seo a leanas sa tslí chéanna.

① $65 \div 20$

④ $84 \div 30$

② $84 \div 20$

⑤ $85 \div 40$

③ $98 \div 20$

⑥ $99 \div 40$

A

Tabhair na huimhreacha seo go dtí an 10 is gaire.

$39 \quad \square \quad 32 \quad \square$

$56 \quad \square \quad 27 \quad \square$

$71 \quad \square \quad 44 \quad \square$

$29 \quad \square \quad 57 \quad \square$

B

Tabhair na huimhreacha seo go dtí an 10 is gaire.

$185 \quad \square \quad 142 \quad \square$

$199 \quad \square \quad 237 \quad \square$

$236 \quad \square \quad 478 \quad \square$

$481 \quad \square \quad 364 \quad \square$

C



① $344 \div 43 = \square$

② $623 \div 89 = \square$

③ $496 \div 62 = \square$

④ $786 \div 78 = \square$

⑤ $294 \div 98 = \square$

⑥ $385 \div 77 = \square$

⑦ $440 \div 88 = \square$

⑧ $456 \div 76 = \square$

D

Cé mhéad uair is féidir liom 10 a dhealú ó na huimhreacha seo?

① 48 \square huaire

② 56 \square huaire

③ 63 \square huaire

④ 87 \square n-uair

⑤ 92 \square n-uair

⑥ 127 \square uair déag

⑦ 108 \square n-uair

⑧ 147 \square huaire déag

Cuimhnigh!

Buille faoi thuairim an-mhaith is ea meastachán.

Is féidir leis a bheith rómhór nó róbheag.



An Roinnteoir

An Inroinnt

An Líon

An Fuílleach

An Líon	→ 4	An Inroinnt	Is é 22 an <input style="width: 50px; height: 20px;" type="text"/>
	$\begin{array}{r} 22 \overline{)89} \\ - 88 \\ \hline 1 \end{array}$		Is é <input style="width: 30px; height: 20px;" type="text"/> an Inroinnt.
An Roinnteoir	→ -88		Is é 4 an <input style="width: 50px; height: 20px;" type="text"/>
An Fuílleach	→ 1		

Beidh colún don obair gharbh uait agus roinnt fhada á déanamh

$$\begin{array}{r} 3 \\ 19 \overline{)57} \\ -57 \\ \hline 00 \end{array}$$

Déan garmheastachán

$$20 \overline{)60} = 3$$

$$\begin{array}{r} 19 \\ \times 3 \\ \hline 57 \end{array}$$

Déan iad seo anois sa tslí chéanna.

① $14 \overline{)56}$

⑤ $13 \overline{)91}$

② $13 \overline{)26}$

⑥ $17 \overline{)51}$

③ $23 \overline{)46}$

⑦ $15 \overline{)60}$

④ $13 \overline{)39}$

⑧ $21 \overline{)84}$

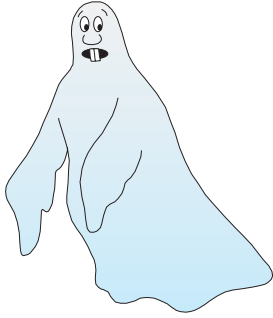

Roinn 14 pháiste 57 úll taifí eatarthu féin Oíche Shamhna. Cé mhéad a fuair gach páiste?

$$\begin{array}{r} 4 \\ 14 \overline{)57} \\ \underline{-56} \\ 1 \end{array}$$



Fuair siad 4 úll taifí an páiste. Bhí ceann amháin fágtha. **FUÍLLEACH** a thugtar air.

An freagra: 4 f 1 (Seasann f do **FUÍLLEACH**).

Déan iad seo anois sa tslí chéanna.

① $13 \overline{)93}$

④ $13 \overline{)28}$

② $17 \overline{)55}$

⑤ $15 \overline{)65}$

③ $23 \overline{)48}$

⑥ $21 \overline{)89}$

DÉAN IAD
SEO ANOIS.



① $14 \overline{)70}$

② $17 \overline{)84}$

③ $19 \overline{)94}$

④ $26 \overline{)79}$

⑤ $13 \overline{)94}$

⑥ $17 \overline{)96}$

⑦ $14 \overline{)97}$

⑧ $19 \overline{)60}$

⑨ $23 \overline{)93}$

⑩ $29 \overline{)88}$

⑪ $17 \overline{)57}$

⑫ $19 \overline{)89}$

Roinnt Fhada (Cuid a Dó)

Tá páistí ann a dhéanann garmheastachán ar an gcéad digit.

e.g. $592 \div 23$

$$\begin{array}{r} 23 \overline{)592} \end{array}$$

Bain triail as 2 i do cholún d'obair gharbh.

$$2 \times 23 = 46$$

Sa Roinnt Fhada

Déan garmheastachán/ Tabhair go dtí an deich is gaire

Ansin:

Roinn

Iolraigh

Dealaigh

Bain anuas an chéad uimhir eile agus tosaigh arís.

Roinn

Iolraigh

Dealaigh

$$\begin{array}{r} 2 \\ 23 \overline{)59} \\ -46 \\ \hline 13 \end{array}$$



$$\textcircled{1} \quad 27 \overline{)149}$$

$$\textcircled{2} \quad 38 \overline{)243}$$

$$\textcircled{3} \quad 307 \div 42$$

$$\textcircled{4} \quad 464 \div 58$$

$$\textcircled{5} \quad 318 \div 36$$

$$\textcircled{6} \quad 352 \div 37$$

$$\textcircled{7} \quad 56 \overline{)293}$$

$$\textcircled{8} \quad 49 \overline{)394}$$

$$\textcircled{9} \quad \begin{array}{r} 279 \\ \hline 28 \end{array}$$

$$\textcircled{10} \quad \begin{array}{r} 268 \\ \hline 28 \end{array}$$

Fadhbanna

Seiceáil do chuid freagraí leis an áireamhán.

- ① Cé mhéad péire bróg ar €64 an péire is féidir a cheannach le €76? Déan garmheastachán ar dtús.
- ② Tá slí ar an mbus do 67 duine. Cé mhéad bus a bheadh ag teastáil le 465 páiste a thabhairt chuig cluiche peile?
- ③ Cheannaigh Rút fáiscín gruaige ar 94c. Cheannaigh Úna sé cinn ar dhathanna éagsúla. Cé mhéad a chaith Úna ar fháiscíní gruaige?
- ④ Cosnaíonn lítear bainne 70c. Cé mhéad lítear bainne a cheannaigh teaghlach más é €4.55 an bille bainne a bhí acu?
- ⑤ Choigil Aoife €432 le haghaidh rothair nua. €16 a choigil sí gach seachtain. Cé mhéad seachtain a thóg sé uirthi an t-airgead a choigilt?
- ⑥ Cé mhéad 36 atá in 828? Déan garmheastachán ar dtús.
- ⑦ Tá 925 mirlín ag Feargus. 25 mirlín a chuireann sé i ngach mála don aonach saothair. Cé mhéad mála mirlíní a dhéanfaidh sé?

Seichimh Uimhreacha

Uimhreacha Triantánacha, Uimhreacha Cearnacha & Uimhreacha Dronuilleogacha

An Fachtóir Coiteann is Airde (FCA)

An tIolraí Coiteann is Lú (ICL)

Uimhreacha Triantánacha



1

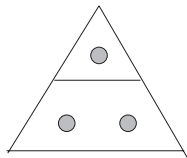

3

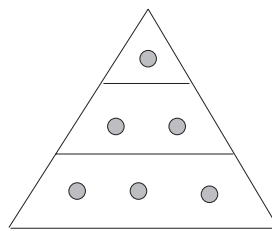

6

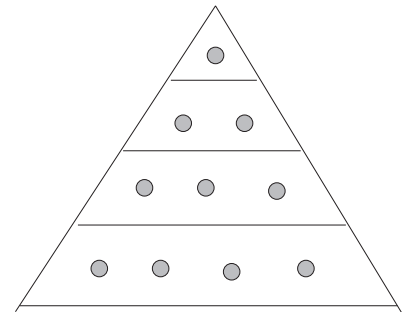

10

Is féidir gach uimhir thriantánach a bhriseadh síos mar seo.

$$1 = 1$$

$$1 + 2 = 3$$

$$1 + 2 + 3 = 6$$

$$1 + 2 + 3 + 4 = 10$$

① $1 + 2 + 3 + 4 + 5 =$

② Cad é an chéad uimhir thriantánach eile?

Is iad seo an chéad seacht n-uimhir thriantánacha:

1, 3, 6, 10, 15, 21, 28.
 +2 +3 +4 +5 +6 +7

Críochnaigh an patrún.

①

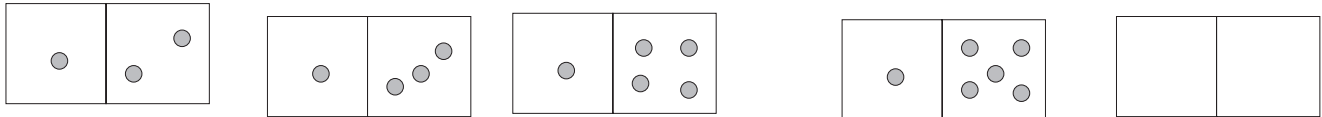

Lean de na patrúin uimhreacha seo.

②

$$12 \times 3 = 36$$

$$36 \div 3 = 12$$

$$3 \times 12 = 36$$

$$\square \div \square = \square$$

③

$$4 \times 4 = 10 + 6$$

$$4 \times 5 = 12 + 8$$

$$4 \times 6 = 14 + 10$$

$$4 \times 7 = 16 + 12$$

$$4 \times 8 = 18 + 14$$

$$\square \times \square = \square + \square$$

④

$$5 \times 6 = 24 + 6$$

$$5 \times 7 = 27 + 8$$

$$5 \times 8 = 30 + 10$$

$$5 \times 9 = 33 + 12$$

$$5 \times 10 = 36 + 14$$

$$\square \times \square = \square + \square$$

⑤

$$(3 \times 5) + 5 = 10 + 10$$

$$(3 \times 5) + 7 = 10 + 12$$

$$(3 \times 5) + 9 = 10 + 14$$

$$(3 \times 5) + 11 = 10 + 16$$

$$(\square \times \square) + \square = \square + \square$$

Uimhreacha Cearnacha

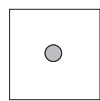

1

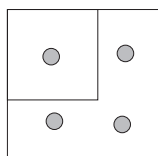

4

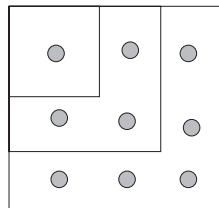

9

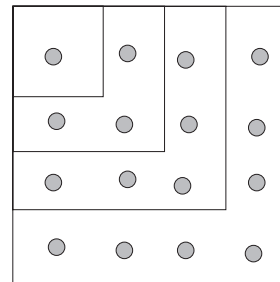

16

$$1 \times 1 = 1$$

 (1^2)

$$2 \times 2 = 4$$

 (2^2)

$$3 \times 3 = 9$$

 (3^2)

$$4 \times 4 = 16$$

 (4^2)

Is féidir na poncphictiúir a bhriseadh síos mar seo:

$$1 = 1$$

$$1 + 3 = 4$$

$$1 + 3 + 5 = 9$$

$$1 + 3 + 5 + 7 = 16 \quad (\text{An féidir leat é sin a fheiceáil sa phoncphictiúr?})$$

Tuilleadh samplaí: $144 = 12 \times 12$

$$81 = 9 \times 9$$

$$64 = 8 \times 8$$



Dronuilleog speisialta
is ea cearnóg.

Uimhreacha Dronuilleogacha

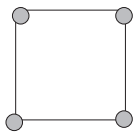

4

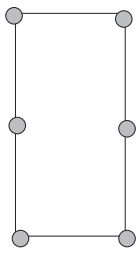

6

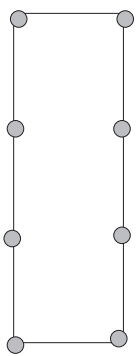

8

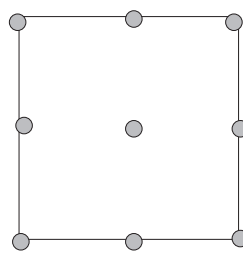

9

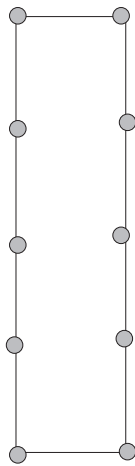

10

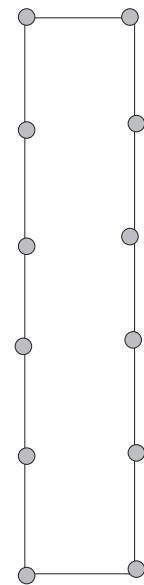

12

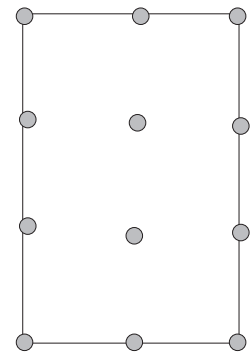

12

① Na huimhreacha 4, , , , , ,

Is féidir a gcruth nó a gcuid fachtóirí a bheith dronuilleogach.

② Tá 2 chruth dhronuilleogacha ag 12. Cén fáth?



Tugtar uimhreacha **ilchodacha** ar na huimhreacha dronuilleogacha, freisin.

① Cuir ciorcal timpeall ar na huimhreacha ilchodacha.

21, 39, 47, 51.

② Cuir ciorcal timpeall ar na huimhreacha triantánacha.

1, 5, 15, 22, 28

③ Cuir ciorcal timpeall ar na huimhreacha príomha.

17, 29, 31, 45.

④ Cuir ciorcal timpeall ar na huimhreacha cearnacha.

25, 9, 21, 16, 49

⑤ Cuir ciorcal timpeall ar na huimhreacha a bhfuil fachtóirí acu.

27, 32, 35, 41, 48.

⑥ Cuir ciorcal timpeall ar na huimhreacha dronuilleogacha.

2, 17, 25, 137

⑦ Scríobh síos na huimhreacha príomha go léir atá níos lú ná 50.



Is uimhreacha **príomha** iad uimhreacha nach uimhreacha dronuilleogacha iad (níl aon fhachtóirí acu).

NÍ uimhir phríomha í 1.



Earatastainéas

Matamaiticeoir sa Ghréig ba ea Earatastainéas. Fuair sé bás thart ar 195 RC. D'aimsigh sé bealach leis an domhan a thomhas. Sa tomhas a rinne sé, ghlac sé leis go raibh an domhan cruinn. Ba é a chreid daoine ag an am sin, agus go ceann na gcéadta bliain ina dhiaidh sin, go raibh an domhan leibhéalta.

Earatastainéas a cheap Criathar Earatastainéas, chomh maith. Córas is ea é sin chun teacht ar uimhreacha príomha.

Bíonn uimhreacha príomha inroinnte ar 1 agus orthu féin, agus sin uile.

Is féidir leat an criathar a oibriú amach duit féin ar an gcéad leathanach eile, faoi mar a d'oibrigh Earatastainéas amach fadó é.

Criathar Earatastainéas

Lean na teoracha thíos agus faigh na huimhreacha príomha suas go dtí 100.

1. Cuir X ar na ré-uimhreacha go léir seachas 2. Cuir ciorcal timpeall ar 2.
2. Cuir ciorcal timpeall ar 3. Cuir X ar iolraithe 3 go léir.
3. Cuir ciorcal timpeall ar 5. Cuir X ar iolraithe 5.
4. Cuir ciorcal timpeall ar 7. Cuir X ar iolraithe 7 go léir.
5. Cuir ciorcal timpeall ar na huimhreacha go léir atá fágtha seachas 1.

Is uimhreacha **Príomha** iad na huimhreacha go léir a bhfuil ciorcal timpeall orthu.

1	2	3	4	5	6	7	8	9	10
11	12	13	14	15	16	17	18	19	20
21	22	23	24	25	26	27	28	29	30
31	32	33	34	35	36	37	38	39	40
41	42	43	44	45	46	47	48	49	50
51	52	53	54	55	56	57	58	59	60
61	62	63	64	65	66	67	68	69	70
71	72	73	74	75	76	77	78	79	80
81	82	83	84	85	86	87	88	89	90
91	92	93	94	95	96	97	98	99	100

Fachtóirí

Tá ceithre thacar éagsúla fachtóirí ag 24.

$$2 \times 12, \quad 6 \times 4, \quad 3 \times 8, \quad 1 \times 24$$

Is iad fachtóirí 24, mar sin, 1, 2, 3, 4, 6, 8, 12, 24.

Tá trí thacar éagsúla fachtóirí ag 18.

$$2 \times 9, \quad 3 \times 6, \quad 1 \times 18$$

Is iad fachtóirí 18, mar sin, 1, 2, 3, 6, 9, 18.

Tá roinnt de na fachtóirí sin sa dá shraith.

Fachtóirí Coiteanna a thugaimid orthu sin.

Is iad seo fachtóirí coiteanna 18 agus 24: 1, 2, 3, 6. Is é 6 an ceann is airde díobh sin. Deirimid, mar sin, gurb é 6 an **Fachtóir Coiteann is Airde** atá ag 18 agus 24.

Scríobhaimid FCA mar ghiorrúchán ar **Fachtóir Coiteann is Airde**.

① Cuir ciorcal timpeall ar na huimhreacha ilchodacha.

13, 15, 17, 20, 24, 28, 29.

② Cuir ciorcal timpeall ar na huimhreacha príomha.

30, 31, 32, 33, 34, 35.



Glactar leis **nach** uimhir phríomha í 1.

Líon isteach na huimhreacha atá in easnamh.

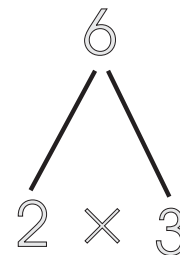
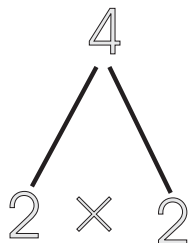
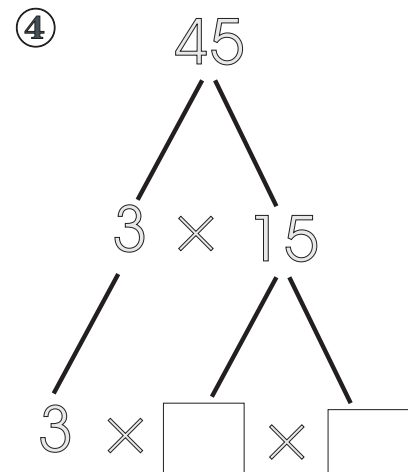
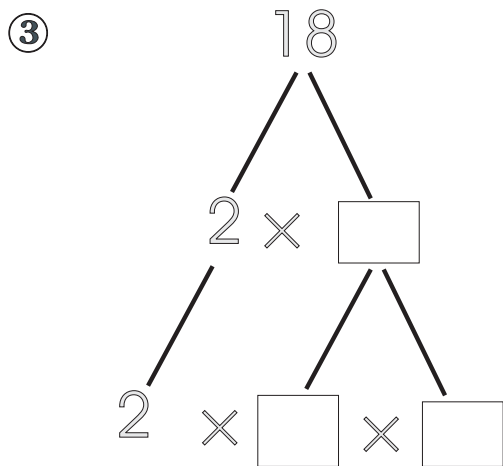
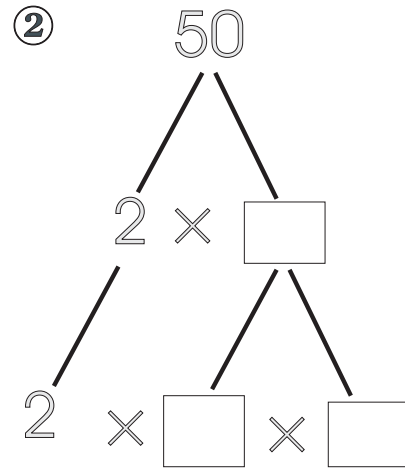
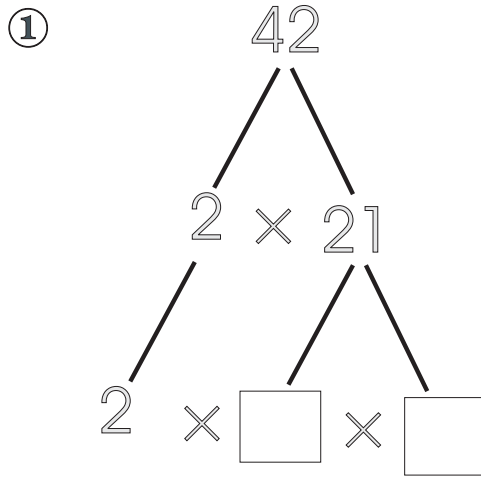

Is fachtóir coiteann é 2 ag 4 agus 6.

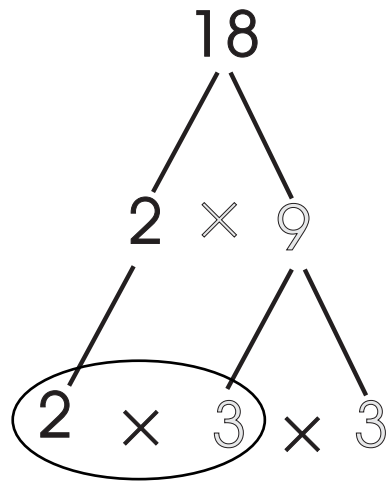
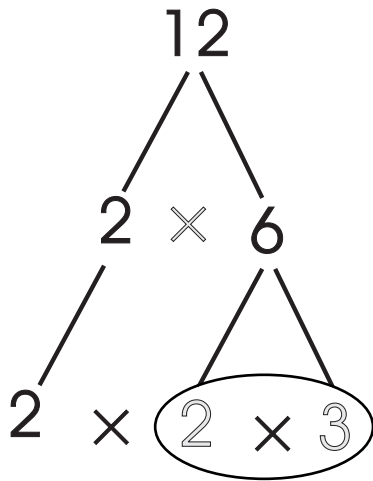

Is féidir fachtóirí 18 a thaispeáint mar seo, chomh maith.

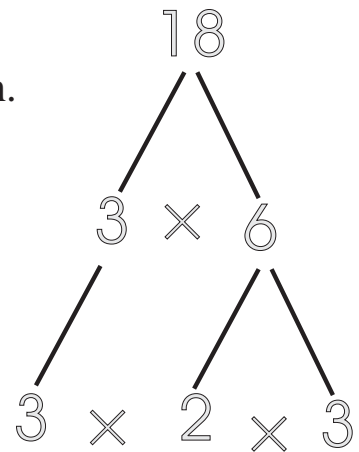

Is fachtóirí coiteanna iad 2, 3, 6 ar an dá thaobh.

Mar sin, is é 6 an FCA atá ag 12 agus ag 18.

① Faigh FCA: 36 agus 42

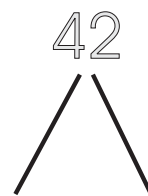
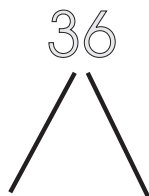

Faigh FCA:



agus

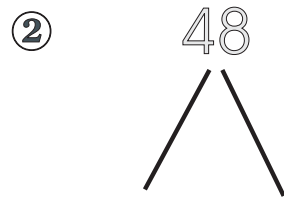
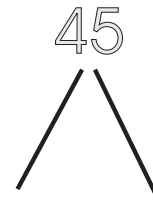

agus

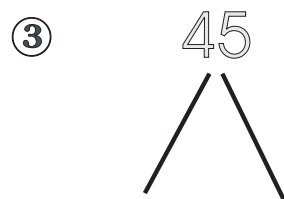
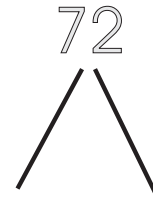

agus

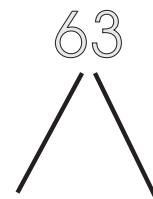

agus

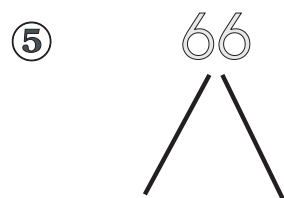
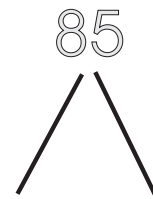

agus

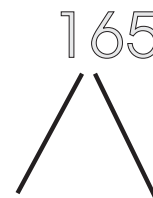

Ceisteanna Ilroghnacha

① Má chuirtear 3 ré-uimhir le corruimhir.

Is é atá sa fhreagra:

- (a) ré-uimhir (b) corruimhir (c) d'fhéadfadh sé a bheith ina ré-uimhir nó ina chorruimhir

② Uimhir phríomha is ea:

- (a) uimhir a bhfuil fachtóirí aici
(b) uimhir gan fachtóirí

③ Roinn ré-uimhir ar 2.

Is é atá sa fhreagra:

- (a) corruimhir (b) ré-uimhir (c) d'fhéadfadh sé a bheith ina ré-uimhir nó ina chorruimhir



Leaschodán is ea $\frac{13}{6}$

Uimhir mheasctha is ea $4\frac{1}{2}$

① Cuir ciorcal timpeall ar na huimhreacha príomha.

1, 3, 4, 5, 6, 7

② Cuir ciorcal timpeall ar na huimhreacha ilchodacha

1, 3, 4, 5, 6, 7

Cuir ciorcal timpeall ar an bhfreagra ceart.

Freagra

③ 2 ré-uimhir agus iad suimithe le chéile.

Corruimhir Ré-uimhir

④ Corruimhir agus ré-uimhir agus iad suimithe le chéile.

Corruimhir Ré-uimhir

⑤ Dhá chorruiimhir agus iad suimithe le chéile.

Corruimhir Ré-uimhir

⑥ Dealraith ré-uimhir ó chorruiimhir.

Corruimhir Ré-uimhir

Líon isteach na boscaí.

⑦ Críochnaíonn na ré-uimhreacha go léir ar

nó nó nó nó

An tIolraí Coiteann is Lú ICL

Fachtóir de 12 is ea 4.

Iolraí 4 is ea 12.

Fachtóir de 35 is ea 5.

Iolraí 5 is ea 35.

Seo roinnt iolraithe atá ag 4: 4, 8, 12, 16, **20**, 24.

Seo roinnt iolraithe atá ag 5: 5, 10, 15, **20**, 25, 30.

Tá 20 sa dá liosta.

Is **iolraí coiteann** ag 4 agus 5 é 20.

Seo roinnt iolraithe atá ag 3: 3, 6, 9, 12, 15, 18, **21**, 24, 27, 30.

Seo roinnt iolraithe atá ag 7: 7, 14, **21**, 28, 35, 42.

Iolraí coiteann ag 3 agus 7 é 21.

Seo roinnt iolraithe atá ag 9: 9, 18, 27, **36**, 45, 54, 63, **72**.

Seo roinnt iolraithe atá ag 12: 12, 24, **36**, 48, 60, **72**, 84, 96.

Tá 36 agus 72 coiteann don dá ghrúpa.

Is é 36 an uimhir is lú díobh sin.

Is é 36 an t-íolraí coiteann is lú atá acu.

An t-Íolraí Coiteann is Lú nó ICL a thugtar air.

① Faigh an tICL ag:

- (a) 5 agus 7
- (b) 12 agus 8
- (c) 24 agus 9
- (d) 36 agus 8
- (e) 20 agus 6
- (f) 15 agus 12

② Faigh an FCA ag:

- (a) 18 agus 24
- (b) 20 agus 15
- (c) 9 agus 15
- (d) 8 agus 12
- (e) 16 agus 36

1	2	3	4	5	6	7	8	9	10
11	12	13	14	15	16	17	18	19	20
21	22	23	24	25	26	27	28	29	30
31	32	33	34	35	36	37	38	39	40
41	42	43	44	45	46	47	48	49	50
51	52	53	54	55	56	57	58	59	60
61	62	63	64	65	66	67	68	69	70
71	72	73	74	75	76	77	78	79	80
81	82	83	84	85	86	87	88	89	90
91	92	93	94	95	96	97	98	99	100

Dathaigh iolraithe 3.

Cuir ciorcal timpeall ar iolraithe 7.

Tá dath ar na hiolraithe **coiteanna** agus tá ciorcal timpeall orthu.

- ① Liostaigh iolraithe 3 (suas go dtí 99).
- ② Liostaigh iolraithe 7 (suas go dtí 98).
- ③ Liostaigh iolraithe coiteanna 3 agus 7 go léir.
- ④ Cuir ciorcal timpeall ar an ICL.

Codáin

Suimiú, Dealú, Iolrú agus Roinnt a dhéanamh ar Chodáin

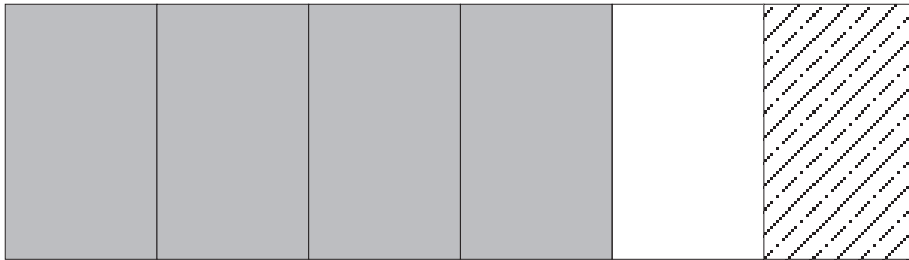

① (a) Cén codán den dronuilleog atá scáthaithe?

(b) Cén codán den dronuilleog atá stríocach?

② (a) Cén codán den chiorcal atá scáthaithe ?

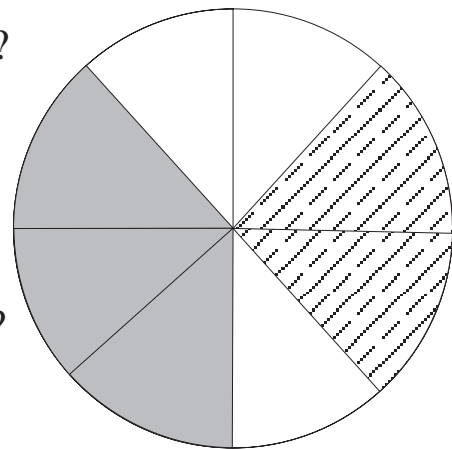

(b) Cén codán den chiorcal atá stríocach ?

③ Cuir dath gorm ar $\frac{1}{4}$ den chiorcal agus cuir dath dearg ar $\frac{1}{8}$ den chiorcal.

Cén codán atá fágtha gan dath?

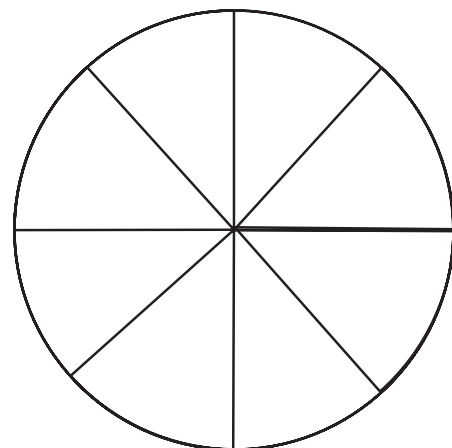

1 aonad amháin

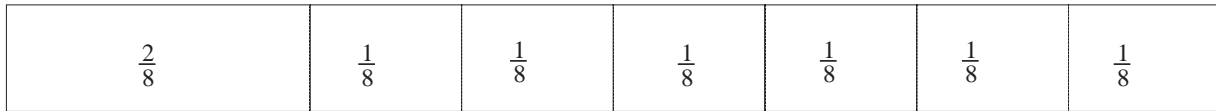
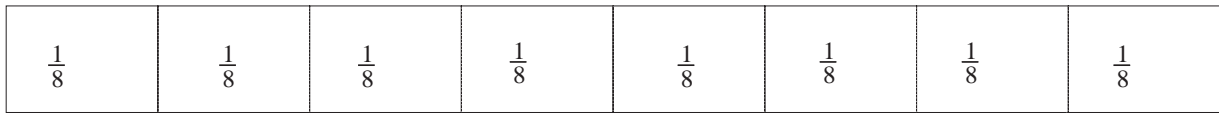

$\frac{8}{8}$ nó 1 aonad amháin

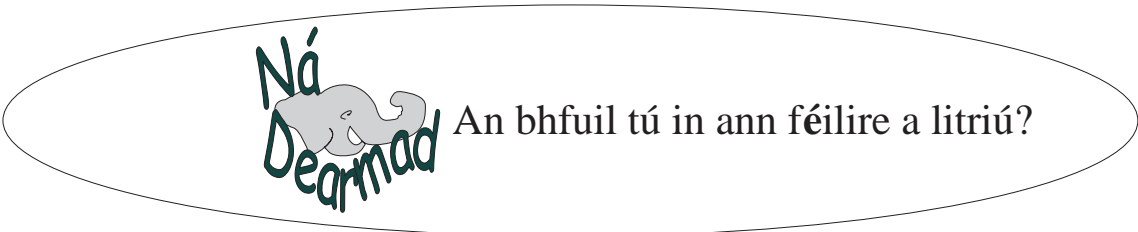

Is féidir le codáin éagsúla seasamh don uimhir chéanna.

Dá réir sin $\frac{1}{2} = \frac{2}{4} = \frac{4}{8}$

Tugtar **codáin choibhéiseacha** ar na codáin sin mar go bhfuil an luach céanna acu.

Féach ar an tábla coibhéiseachta thíos.

Ón tábla seiceáil gur mar seo atá: $\frac{1}{2} = \frac{2}{4} = \frac{4}{8}$

aon aonad amháin

$\frac{1}{2}$

$\frac{1}{2}$

$\frac{1}{3}$

$\frac{1}{3}$

$\frac{1}{3}$

$\frac{1}{4}$

$\frac{1}{4}$

$\frac{1}{4}$

$\frac{1}{4}$

$\frac{1}{5}$

$\frac{1}{5}$

$\frac{1}{5}$

$\frac{1}{5}$

$\frac{1}{5}$

$\frac{1}{6}$

$\frac{1}{6}$

$\frac{1}{6}$

$\frac{1}{6}$

$\frac{1}{6}$

$\frac{1}{6}$

$\frac{1}{7}$

$\frac{1}{7}$

$\frac{1}{7}$

$\frac{1}{7}$

$\frac{1}{7}$

$\frac{1}{7}$

$\frac{1}{7}$

$\frac{1}{8}$

$\frac{1}{8}$

$\frac{1}{8}$

$\frac{1}{8}$

$\frac{1}{8}$

$\frac{1}{8}$

$\frac{1}{8}$

$\frac{1}{8}$

$\frac{1}{9}$

$\frac{1}{9}$

$\frac{1}{9}$

$\frac{1}{9}$

$\frac{1}{9}$

$\frac{1}{9}$

$\frac{1}{9}$

$\frac{1}{9}$

$\frac{1}{9}$

$\frac{1}{10}$

$\frac{1}{10}$

$\frac{1}{10}$

$\frac{1}{10}$

$\frac{1}{10}$

$\frac{1}{10}$

$\frac{1}{10}$

$\frac{1}{10}$

$\frac{1}{10}$

$\frac{1}{10}$

Críochnaigh iad seo a leanas.

Seiceáil do chuid freagraí leis an tábla coibhéiseachta.

① $\frac{1}{2} = \frac{\square}{8}$ $\frac{3}{4} = \frac{\square}{8}$ $\frac{8}{8} = \frac{2}{\square}$ $\frac{2}{8} = \frac{\square}{4}$

② $1 = \frac{4}{\square}$ $1 - \frac{1}{4} = \frac{\square}{4}$ $1 - \frac{3}{8} = \frac{5}{\square}$ $1 - \frac{7}{8} = \frac{1}{\square}$

③ $\frac{2}{3} = \frac{\square}{9}$ $\frac{3}{9} = \frac{1}{\square}$ $\frac{3}{3} = \frac{\square}{6}$ $\frac{2}{3} = \frac{\square}{6}$

④ $1 - \frac{1}{3} = \frac{2}{\square}$ $1 - \frac{2}{3} = \frac{\square}{9}$ $1 - \frac{\square}{3} = \frac{2}{3}$ $1 - \frac{2}{\square} = \frac{1}{3}$

⑤ (a) Bain úsáid as péire de na cártaí agus déan codán atá níos lú ná $\frac{1}{2}$

7

5

11

3

9

$\frac{\square}{\square}$

(b) Cé mhéad níos lú ná 1 atá do chodánsa?

$\frac{\square}{\square}$

①

- a. Ithim $\frac{1}{3}$. Tá fágtha agam.
- b. Ithim $\frac{1}{2}$. Tá fágtha agam.
- c. Ithim $\frac{1}{4}$. Tá fágtha agam.
- d. Ithim $\frac{1}{8}$. Tá fágtha agam.
- e. Ithim $\frac{1}{10}$. Tá fágtha agam.



②

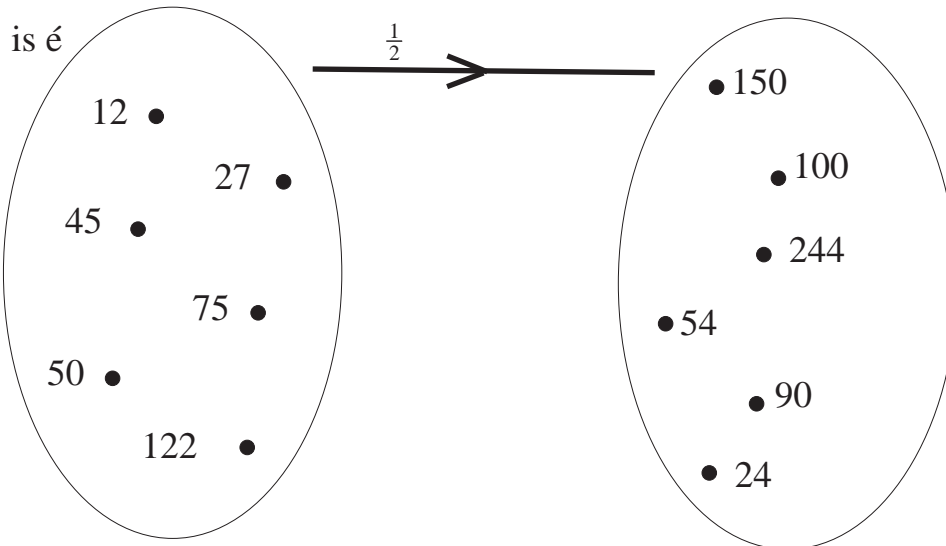

③



Léirítear an uimhir 72 thuas.

- a. $\frac{3}{3}$ den uimhir is ea =
- b. $\frac{2}{3}$ den uimhir is ea =
- c. $\frac{1}{3}$ den uimhir is ea =

aon aonad amháin									
$\frac{1}{2}$					$\frac{1}{2}$				
$\frac{1}{3}$			$\frac{1}{3}$			$\frac{1}{3}$			
$\frac{1}{4}$		$\frac{1}{4}$		$\frac{1}{4}$		$\frac{1}{4}$			
$\frac{1}{5}$		$\frac{1}{5}$		$\frac{1}{5}$		$\frac{1}{5}$		$\frac{1}{5}$	
$\frac{1}{6}$		$\frac{1}{6}$		$\frac{1}{6}$		$\frac{1}{6}$		$\frac{1}{6}$	
$\frac{1}{7}$		$\frac{1}{7}$		$\frac{1}{7}$		$\frac{1}{7}$		$\frac{1}{7}$	
$\frac{1}{8}$		$\frac{1}{8}$		$\frac{1}{8}$		$\frac{1}{8}$		$\frac{1}{8}$	
$\frac{1}{9}$		$\frac{1}{9}$		$\frac{1}{9}$		$\frac{1}{9}$		$\frac{1}{9}$	
$\frac{1}{10}$		$\frac{1}{10}$		$\frac{1}{10}$		$\frac{1}{10}$		$\frac{1}{10}$	

Líon isteach na frámaí thíos. Bain úsáid as an gcairt thuas.

1

a. $\frac{1}{2} + \frac{1}{8} = \frac{\square}{8}$

b. $\frac{1}{2} + \frac{3}{8} = \frac{\square}{8}$

c. $\frac{1}{4} + \frac{1}{8} = \frac{\square}{\square}$

d. $\frac{1}{2} + \frac{1}{8} = \frac{\square}{\square}$

e. $\frac{1}{2} + \frac{1}{4} = \frac{\square}{\square}$

f. $\frac{1}{2} + \frac{1}{4} + \frac{1}{8} = \frac{\square}{\square}$

g. $\frac{1}{3} = \frac{2}{\square}$

h. $\frac{1}{3} + \frac{2}{6} = \frac{\square}{3}$

i. $\frac{2}{3} - \frac{2}{6} = \frac{\square}{6}$

j. $\frac{3}{5} - \frac{2}{5} = \frac{\square}{\square}$

k. $\frac{4}{5} - \frac{1}{10} = \frac{\square}{\square}$

l. $\frac{2}{10} + \frac{6}{10} = \frac{\square}{5}$

m. $\frac{\square}{10} = \frac{4}{5}$

n. $\frac{5}{10} = \frac{1}{\square}$

o. $\frac{1}{2} = \frac{\square}{6}$

p. $\frac{1}{2} = \frac{\square}{8}$

q. $\frac{1}{2} = \frac{\square}{10}$

r. $\frac{1}{5} + \frac{1}{10} = \frac{\square}{10}$

Féach an **chuid** seo den uimhirlíne. Scrúdaigh í.

An féidir leat na leaschodáin a scríobh isteach ag na heangaí?

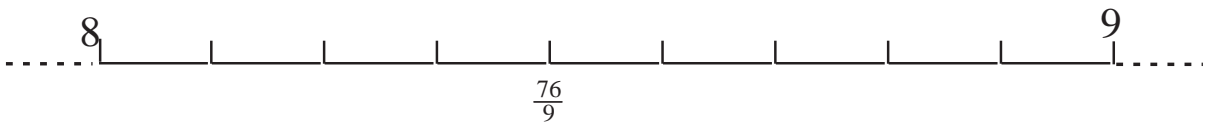
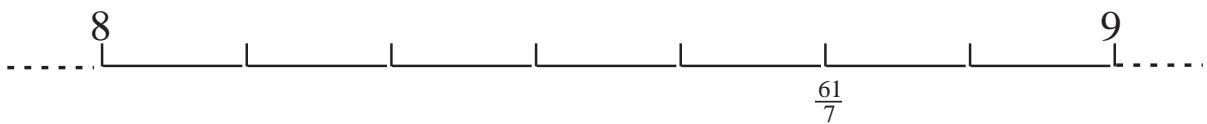
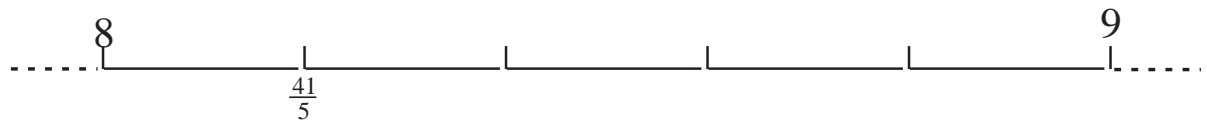
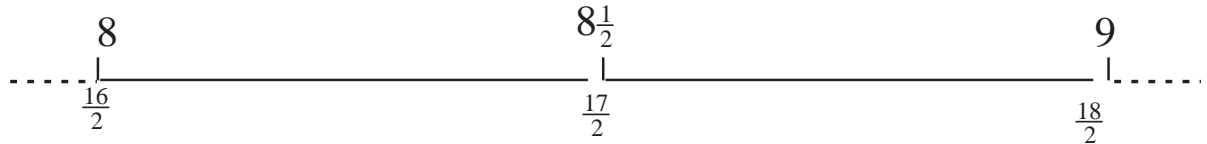

① Léiríonn an léaráid seo thíos go bhfuil $\frac{1}{2} = \frac{\square}{\square}$



② Cuir ciorcal timpeall ar an gcodán atá níos lú ná $\frac{1}{2}$

$\frac{4}{8}$ $\frac{6}{10}$ $\frac{6}{8}$ $\frac{4}{10}$ $\frac{2}{4}$ $\frac{5}{8}$

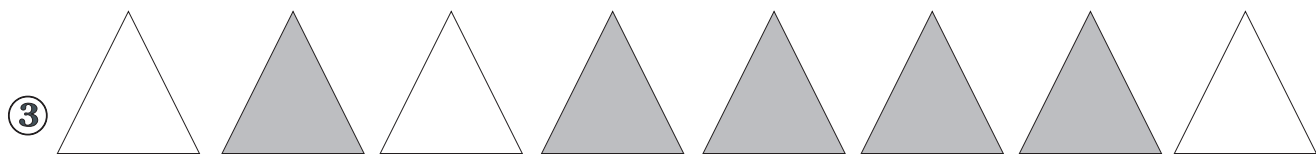

As na dtriantán, tá thriantán scáthaithe.

Is é $\frac{\square}{\square}$ an codán atá scáthaithe.

④ Cén codán atá scáthaithe?

$\frac{33}{6}$ $\frac{3}{3}$ $\frac{1}{3}$ $\frac{6}{9}$

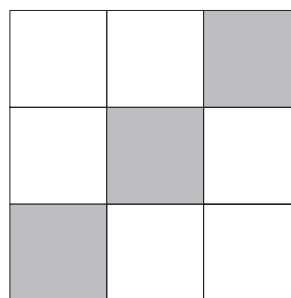

⑤ Cuir ciorcal timpeall ar an gcruth ina bhfuil uimhir ar féidir í a roinnt ar 4, 6 agus 9 gan fuilleach a fhágáil.

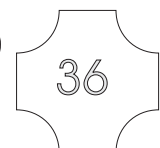
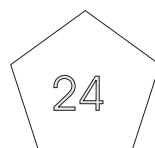

Codáin a Shuimiú agus a Dhealú

An t-uimhreoir a thugtar ar an uimhir os cionn na líne i gcodán.

An t-ainmneoir a thugtar ar an uimhir faoin líne i gcodán.

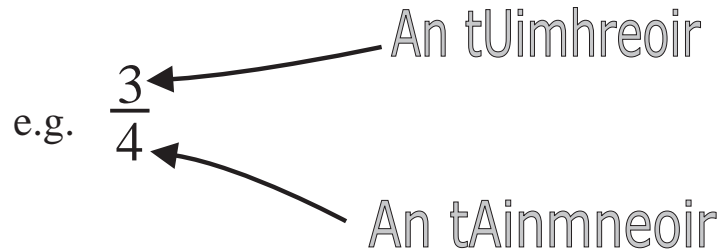

Codáin a shuimiú a bhfuil an t-ainmneoir céanna acu.

Samplaí: $\frac{1}{4} + \frac{1}{4} = \frac{2}{4}$

$$\frac{3}{8} + \frac{4}{8} = \frac{7}{8}$$

$$\frac{1}{5} + \frac{3}{5} = \frac{4}{5}$$

Codáin a shuimiú nach bhfuil an t-ainmneoir céanna acu.

Is féidir sraitheanna de chodáin choibhéiseacha a úsáid le codáin a fháil a bhfuil an t-ainmneoir céanna acu.

Samplaí de chodáin
choibhéiseacha

$\frac{1}{2}$	$\frac{2}{4}$	$\frac{3}{6}$	$\frac{4}{8}$
---------------	---------------	---------------	---------------

$\frac{1}{3}$	$\frac{2}{6}$	$\frac{3}{9}$	$\frac{4}{12}$
---------------	---------------	---------------	----------------

$\frac{1}{4}$	$\frac{2}{8}$	$\frac{3}{12}$	$\frac{4}{16}$
---------------	---------------	----------------	----------------

Sampla: $\frac{1}{2} + \frac{1}{3}$

Ach breathnú ar liostaí na gcodán
coibhéiseach is féidir na codáin a
leanas a athainmniú mar seo: $\frac{1}{2} \rightarrow \frac{3}{6}$
 $\frac{1}{3} \rightarrow \frac{2}{6}$

Dá réir sin $\frac{3}{6} + \frac{2}{6} = \frac{5}{6}$

Codáin a dhealú a bhfuil an t-ainmneoir céanna acu.

Samplaí: $\frac{2}{4} - \frac{1}{4} = \frac{1}{4}$

$\frac{4}{8} - \frac{3}{8} = \frac{1}{8}$

$\frac{3}{5} - \frac{1}{5} = \frac{2}{5}$

Codáin a dhealú nach bhfuil an t-ainmneoir céanna acu.

Is féidir sraitheanna de chodáin choibhéiseacha a úsáid le codáin a fháil a bhfuil an t-ainmneoir céanna acu.

Samplaí de chodáin choibhéiseacha iad seo a leanas:

$\frac{1}{2}$	$\frac{2}{4}$	$\frac{3}{6}$	$\frac{4}{8}$
---------------	---------------	---------------	---------------

$\frac{1}{3}$	$\frac{2}{6}$	$\frac{3}{9}$	$\frac{4}{12}$
---------------	---------------	---------------	----------------

$\frac{1}{4}$	$\frac{2}{8}$	$\frac{3}{12}$	$\frac{4}{16}$
---------------	---------------	----------------	----------------

Sampla: $\frac{1}{2} - \frac{1}{3}$

Níl ainmneoir coiteann ag na codáin seo. Úsáidimid codáin choibhéiseacha ina áit sin ar an gcaoi seo a leanas:

$\frac{1}{2} \rightarrow \frac{3}{6} \quad \frac{1}{3} \rightarrow \frac{2}{6}$

Dá réir sin $\frac{3}{6} - \frac{2}{6} = \frac{1}{6}$



Bíodh an t-ainmneoir céanna ag an dá chodán sula ndéana tú iad a shuimiú nó a dhealú.

Aon aonad amháin											
$\frac{1}{2}$						$\frac{1}{2}$					
$\frac{1}{3}$				$\frac{1}{3}$				$\frac{1}{3}$			
$\frac{1}{4}$			$\frac{1}{4}$			$\frac{1}{4}$			$\frac{1}{4}$		
$\frac{1}{5}$		$\frac{1}{5}$		$\frac{1}{5}$		$\frac{1}{5}$		$\frac{1}{5}$		$\frac{1}{5}$	
$\frac{1}{6}$		$\frac{1}{6}$		$\frac{1}{6}$		$\frac{1}{6}$		$\frac{1}{6}$		$\frac{1}{6}$	
$\frac{1}{7}$		$\frac{1}{7}$		$\frac{1}{7}$		$\frac{1}{7}$		$\frac{1}{7}$		$\frac{1}{7}$	
$\frac{1}{8}$	$\frac{1}{8}$	$\frac{1}{8}$	$\frac{1}{8}$	$\frac{1}{8}$	$\frac{1}{8}$	$\frac{1}{8}$	$\frac{1}{8}$	$\frac{1}{8}$	$\frac{1}{8}$	$\frac{1}{8}$	$\frac{1}{8}$
$\frac{1}{9}$	$\frac{1}{9}$	$\frac{1}{9}$	$\frac{1}{9}$	$\frac{1}{9}$	$\frac{1}{9}$	$\frac{1}{9}$	$\frac{1}{9}$	$\frac{1}{9}$	$\frac{1}{9}$	$\frac{1}{9}$	$\frac{1}{9}$
$\frac{1}{10}$	$\frac{1}{10}$	$\frac{1}{10}$	$\frac{1}{10}$	$\frac{1}{10}$	$\frac{1}{10}$	$\frac{1}{10}$	$\frac{1}{10}$	$\frac{1}{10}$	$\frac{1}{10}$	$\frac{1}{10}$	$\frac{1}{10}$
$\frac{1}{12}$	$\frac{1}{12}$	$\frac{1}{12}$	$\frac{1}{12}$	$\frac{1}{12}$	$\frac{1}{12}$	$\frac{1}{12}$	$\frac{1}{12}$	$\frac{1}{12}$	$\frac{1}{12}$	$\frac{1}{12}$	$\frac{1}{12}$

Sampla

(féach na píosaí scáthaithe thuas)

$$\frac{1}{3} + \frac{1}{4}$$

Athscríobh an dá chodán ionas go mbeidh an t-ainmneoir céanna acu.

$$\frac{4}{12} + \frac{3}{12}$$

Freagra: $\frac{7}{12}$

Tá bealach sciobtha le hiad seo a dhéanamh.

Ar aimsigh tú é?

①

$$(a) \frac{\square}{6} = \frac{3}{18}$$

$$(b) \frac{\square}{6} = \frac{9}{18}$$

$$(c) \frac{\square}{8} = \frac{18}{24}$$

$$(d) \frac{\square}{6} = \frac{4}{12}$$

$$(e) \frac{\square}{10} = \frac{5}{50}$$

$$(f) \frac{\square}{12} = \frac{6}{24}$$

$$(g) \frac{\square}{32} = \frac{1}{16}$$

②

$$(a) \frac{5}{6} = \frac{\square}{30}$$

$$(b) \frac{4}{6} = \frac{\square}{18}$$

$$(c) \frac{7}{\square} = \frac{21}{24}$$

$$(d) \frac{3}{7} = \frac{9}{\square}$$

$$(e) \frac{8}{20} = \frac{\square}{100}$$

$$(f) \frac{\square}{30} = \frac{9}{10}$$

$$(g) \frac{\square}{21} = \frac{1}{3}$$

Uimhir **mheasctha** is ea slánuimhir agus codán curtha léi.

① Cuir ciorcal timpeall ar na huimhreacha measctha.

$$\frac{1}{2} \quad 3\frac{1}{2} \quad 4\frac{1}{8} \quad \frac{3}{4} \quad \frac{1}{10}$$

Leaschodán is ea codán ina bhfuil an t-uimhreoir níos mó ná an t-ainmneoir.

e.g. $\frac{5}{4}$

② Cuir ciorcal timpeall ar na leaschodáin.

$$\frac{3}{2} \quad \frac{10}{5} \quad \frac{1}{2} \quad \frac{2}{3} \quad \frac{6}{5}$$

Uimhreacha Measctha a Shuimiú

Sampla:

$$\begin{aligned} 2\frac{5}{6} + 1\frac{3}{4} & \text{ Faigh an ICL ar dtús.} \\ = 2 + \frac{10}{12} + 1 + \frac{9}{12} \\ = 3 + \frac{19}{12} \\ = 4 + \frac{7}{12} \\ = 4\frac{7}{12} \end{aligned}$$

③ Déan iad seo anois.

(a) $5\frac{3}{7} + 2\frac{1}{2}$

(b) $3\frac{1}{2} + 1\frac{6}{7}$

(c) $4\frac{2}{3} + 3\frac{4}{5}$

(d) $1\frac{7}{8} + 1\frac{3}{4}$

(e) $5\frac{7}{9} + 6\frac{2}{3}$

Codáin a Dhealú

$$\begin{aligned}
 \text{Sampla 1:} \quad & 4\frac{3}{8} - 2\frac{1}{6} \\
 & = 4\frac{9}{24} - 2\frac{4}{24} \\
 & = 2\frac{5}{24}
 \end{aligned}$$

$$\begin{aligned}
 \text{Sampla 2:} \quad & 4\frac{2}{3} - 2\frac{3}{4} \\
 & = 4\frac{8}{12} - 2\frac{9}{12}
 \end{aligned}$$

Déanaimid leaschodáin de na huimhreacha measctha anois.

$$\begin{aligned}
 & = \frac{56}{12} - \frac{33}{12} \\
 & = \frac{23}{12} \\
 & = 1\frac{11}{12}
 \end{aligned}$$

B'fhéidir go mbeadh an bealach seo níos éasca.

$$\begin{aligned}
 \text{Sampla 3:} \quad & 4\frac{2}{3} - 2\frac{3}{4} \\
 & = 4\frac{8}{12} - 2\frac{9}{12} \\
 & \text{Scríobh } 4\frac{8}{12} \text{ mar } 3\frac{20}{12} \\
 & 3\frac{20}{12} - 2\frac{9}{12} \\
 & = 1\frac{11}{12}
 \end{aligned}$$

①

(a) $2\frac{4}{5} + 3\frac{3}{4} =$

(b) $5\frac{3}{8} + 2\frac{1}{4} =$

(c) $2\frac{7}{8} + 2\frac{5}{8} =$

(d) $6\frac{4}{9} + 2\frac{1}{3} =$

(e) $3\frac{3}{4} + 4\frac{5}{6} =$

②

(a) $3\frac{1}{2} - 2\frac{2}{3} =$

(b) $4\frac{7}{8} - 1\frac{9}{10} =$

(c) $3\frac{5}{6} - \frac{11}{12} =$

(d) $5\frac{1}{2} - 2\frac{3}{5} =$

(e) $3\frac{3}{5} - 1\frac{7}{8} =$

③

(a) $4 - 2\frac{1}{3} =$

(b) $2\frac{9}{10} + 3\frac{3}{4} =$

(c) $7\frac{5}{7} - 4\frac{3}{4} =$

(d) $5\frac{1}{5} + 4\frac{4}{5} =$

(e) $4\frac{5}{8} + 4\frac{1}{3} =$

④

(a) $\frac{3}{4} + \frac{7}{8} + \frac{1}{2} =$

(b) $\frac{3}{4} + \frac{7}{8} - \frac{1}{2} =$

(c) $2\frac{3}{4} + 1\frac{1}{4} - \frac{7}{8} =$

(d) $4\frac{5}{6} + 2\frac{1}{3} - 3\frac{1}{2} =$

(e) $4\frac{1}{4} + 5\frac{2}{3} - \frac{1}{2} =$

Codáin a Iolrú

Iolraímid
an t-ainmneoir faoin ainmneoir
agus
an t-uimhreoir faoin uimhreoir
agus codáin á n-iolrú againn.

Sampla: $\frac{2}{3} \times \frac{1}{6}$
 $= \frac{2}{18}$

①

(a) $\frac{5}{6} \times \frac{3}{4} =$

(b) $\frac{1}{2} \times \frac{5}{10} =$

(c) $\frac{7}{8} \times \frac{5}{6} =$

(d) $\frac{2}{5} \times \frac{3}{4} =$

(e) $\frac{6}{7} \times \frac{1}{4} =$

(f) $\frac{5}{8} \times \frac{9}{10} =$

(g) $\frac{11}{12} \times \frac{1}{2} =$

(h) $\frac{1}{5} \times \frac{7}{8} =$



Dhá dhronuillinn le chéile,
déanann siad uillinn dhíreach (180°).

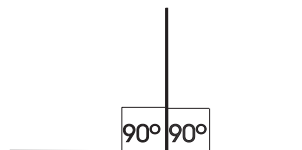

Déan leaschodáin de na huimhreacha measctha ar dtús.

$$\begin{aligned} \text{Sampla: } & 7\frac{1}{2} \times 2\frac{1}{4} \\ & = \frac{15}{2} \times \frac{9}{4} \\ & = \frac{135}{8} \\ & = 16\frac{7}{8} \end{aligned}$$



‘Iolraithe faoi’ is brí le ‘de’ in abairtí ar nós “Faigh $\frac{3}{4}$ de 5”.

①

(a) $2\frac{3}{4} \times 3\frac{2}{5} =$

(b) $3\frac{5}{6} \times 5\frac{1}{9} =$

(c) $2\frac{2}{7} \times 1\frac{3}{4} =$

(d) $6\frac{1}{4} \times 4\frac{1}{5} =$

(e) $3\frac{1}{6} \times 4\frac{1}{9} =$

②

Faigh

(a) $\frac{3}{4}$ de $2\frac{1}{3}$

(b) $\frac{5}{6}$ de $3\frac{3}{4}$

(c) $\frac{2}{5}$ de $8\frac{1}{2}$

(d) $\frac{1}{2}$ de $8\frac{3}{4}$

Codáin a Roinnt

Agus codán á roinnt ar chodán
athraímid an comhartha ‘roinnte ar’ \div ina chomhartha ‘iolraithe faoi’ \times
agus
scríobhaimid an dara codán bun os cionn.

Sampla 1: $\frac{5}{6} \div \frac{5}{12}$

$$= \frac{5}{6} \times \frac{12}{5}$$

Is féidir é seo a oibriú amach ach cealú mar seo a leanas:

$$\frac{\overset{1}{\cancel{5}}}{\underset{1}{\cancel{6}}} \times \frac{\overset{2}{\cancel{12}}}{\underset{1}{\cancel{5}}} = \frac{2}{1} = 2$$

Sampla 2: $2\frac{1}{3} \div 3\frac{1}{9}$

$$= \frac{7}{3} \div \frac{28}{9}$$

$$= \frac{\overset{1}{\cancel{7}}}{\underset{1}{\cancel{3}}} \times \frac{\overset{3}{\cancel{9}}}{\underset{4}{\cancel{28}}} = \frac{3}{4}$$

Déan iad seo anois.

① $1\frac{1}{4} \div 3\frac{1}{8}$

② $1\frac{1}{2} \div \frac{2}{3}$

③ $3\frac{1}{2} \div 4\frac{2}{3}$

④ $3\frac{1}{8} \div 1\frac{1}{4}$

⑤ $6\frac{2}{3} \div 2\frac{1}{2}$

Cén codán de na cruthanna seo atá scáthaithe ?

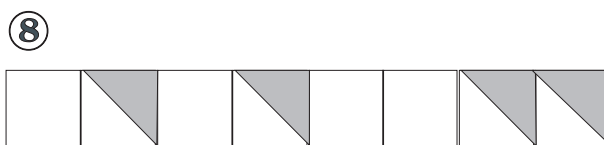
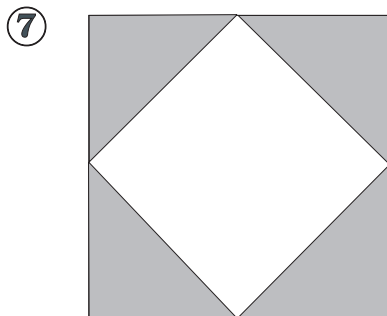
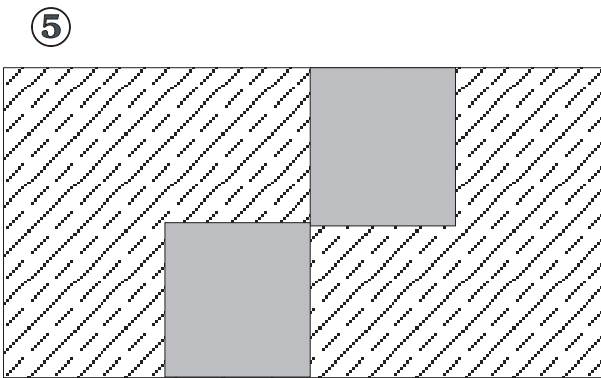
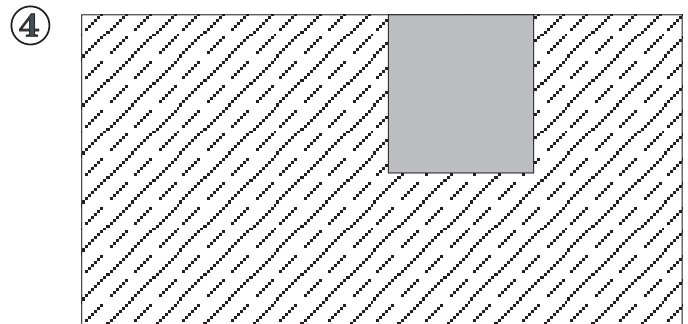
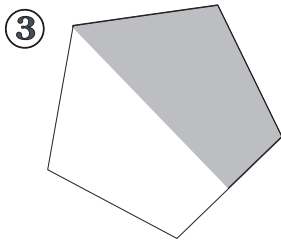
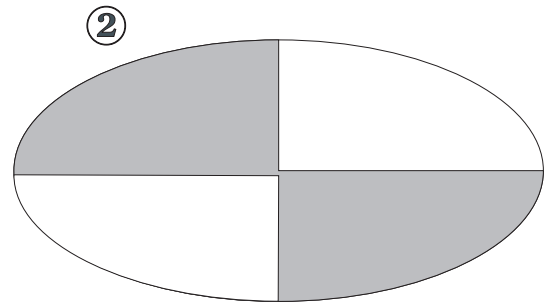
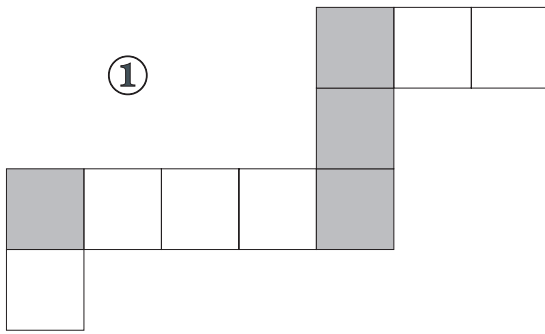

Achar agus Imlíne

Focal eile ar ‘achar’ is ea ‘dromchla’.
Dromchla urláir agus a leithéid a bhíonn i gceist agus suimeanna achair á ndéanamh againn.



Faigh achar na gcruthanna seo trí na cearnóga agus na leathchearnóga a chomhaireamh.

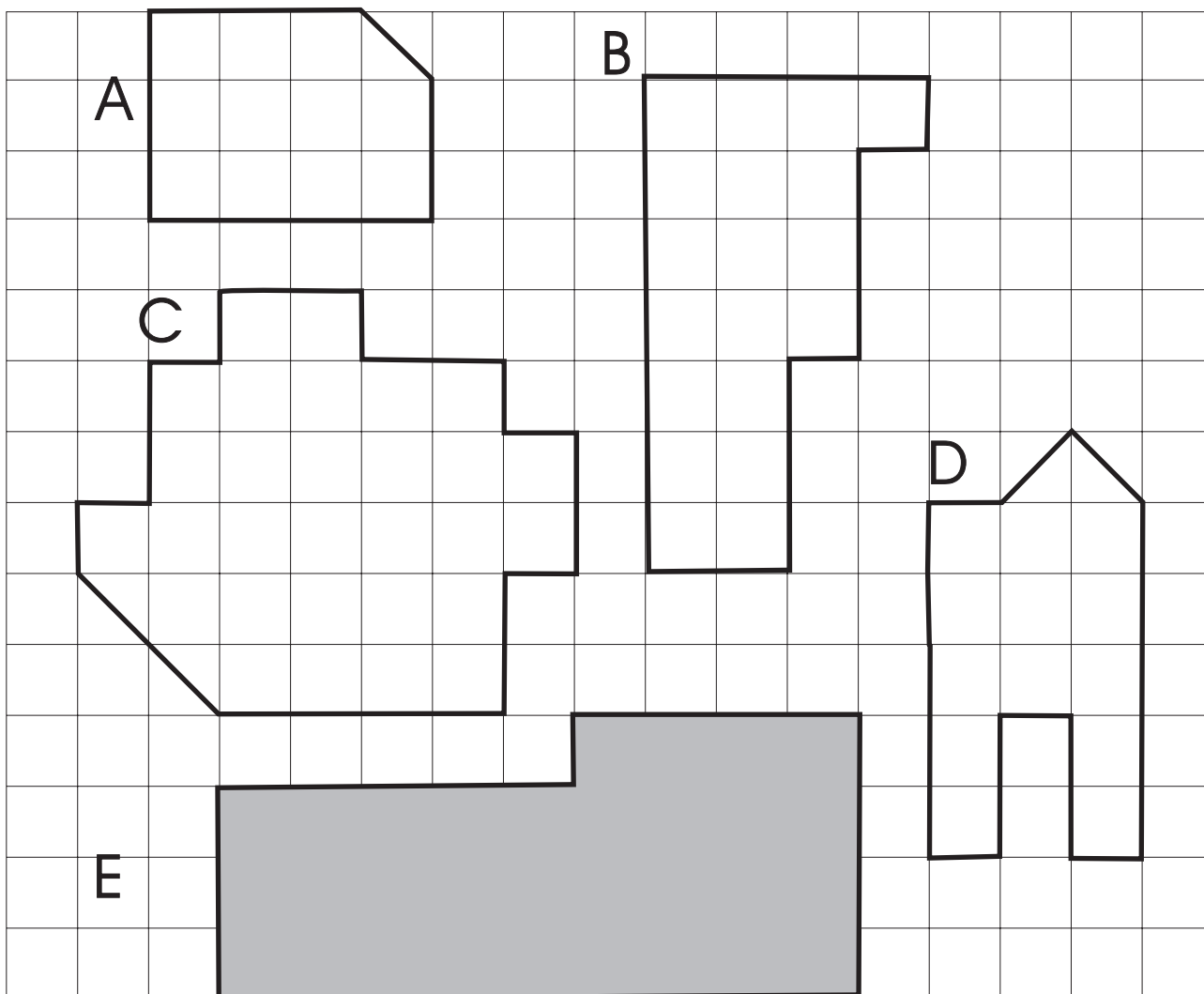

Is ionann imlíne agus an t-imeall ar fad atá ar chruth.
Thomhaisfeadh siúinéir imlíne seomra le go mbeadh a fhios aige cén méid cláir sciortála a bhí le ceannach.
Thomhaisfeadh feirmeoir imlíne páirce agus sreang á ceannach aige do chlaí.

Faigh achar gach crutha. Is ionann gach cearnóg bheag agus 1cm^2

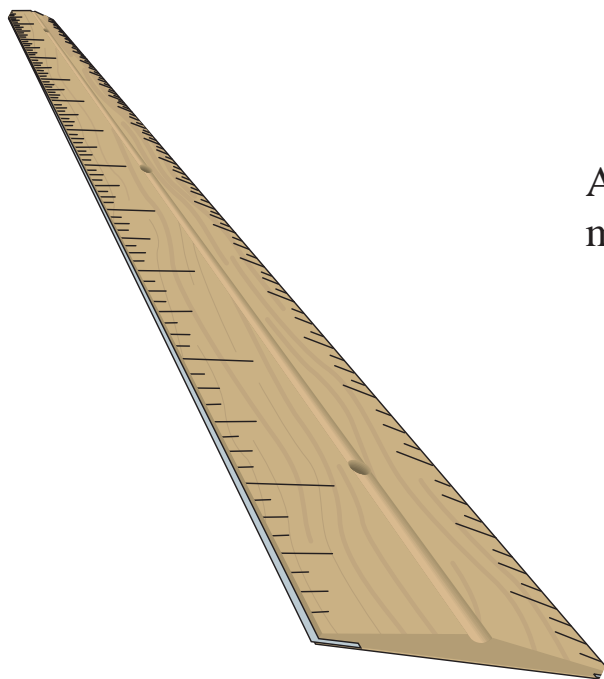
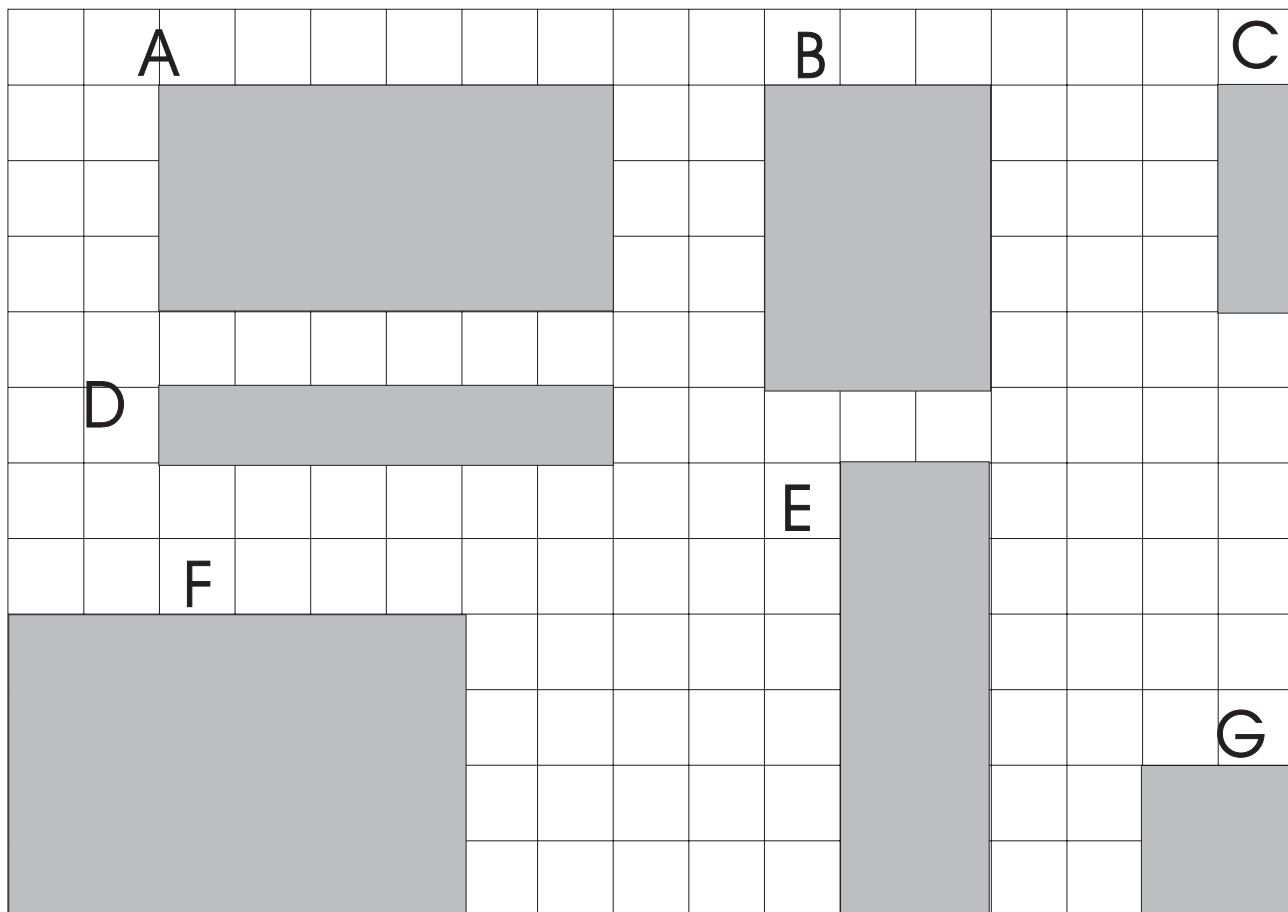

An bhfuil bealach tapa ann le méid an dromchla a fháil ?

Is é 24 cm^2 an freagra ar cheist F thuas. (Ceithre cheintiméadar chearnacha is fiche an bhrí atá leis sin). In áit na cearnóga go léir a chomhaireamh d'fhéadfaimis an freagra a fháil ach 4 cm a iolrú faoi 6 cm.

Déan iad seo ar an mbealach tapa. Scríobh an freagra sa chruth.

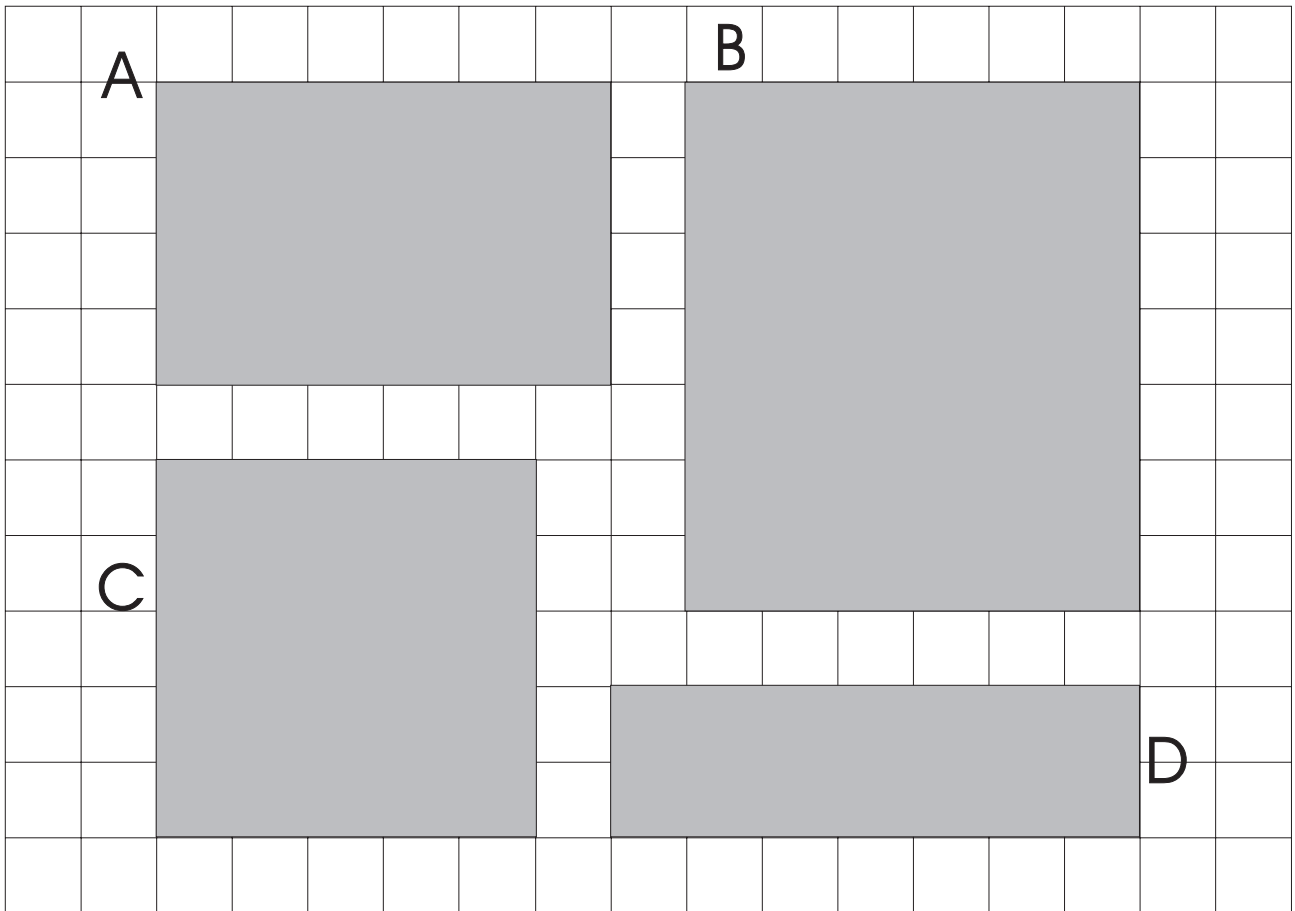

① $12 \text{ cm} \times 7 \text{ cm} =$

② $9 \text{ cm} \times 12 \text{ cm} =$

③ $11 \text{ cm} \times 5 \text{ cm} =$

④ $10 \text{ cm} \times 11 \text{ cm} =$

⑤ $7 \text{ cm} \times 9 \text{ cm} =$

⑥ $8 \text{ cm} \times 6 \text{ cm} =$

⑦ $4 \text{ cm} \times 8 \text{ cm} =$

⑧ $6 \text{ cm} \times 7 \text{ cm} =$

⑨ $9 \text{ cm} \times 5 \text{ cm} =$

⑩ $4 \text{ cm} \times 4 \text{ cm} =$

Is é seo urlár an ghrianáin nua.

Cé mhéad tíl dhubh atá ann?

Cé mhéad tíl bhán atá ann?

Cé mhéad tíl atá ann ar fad?

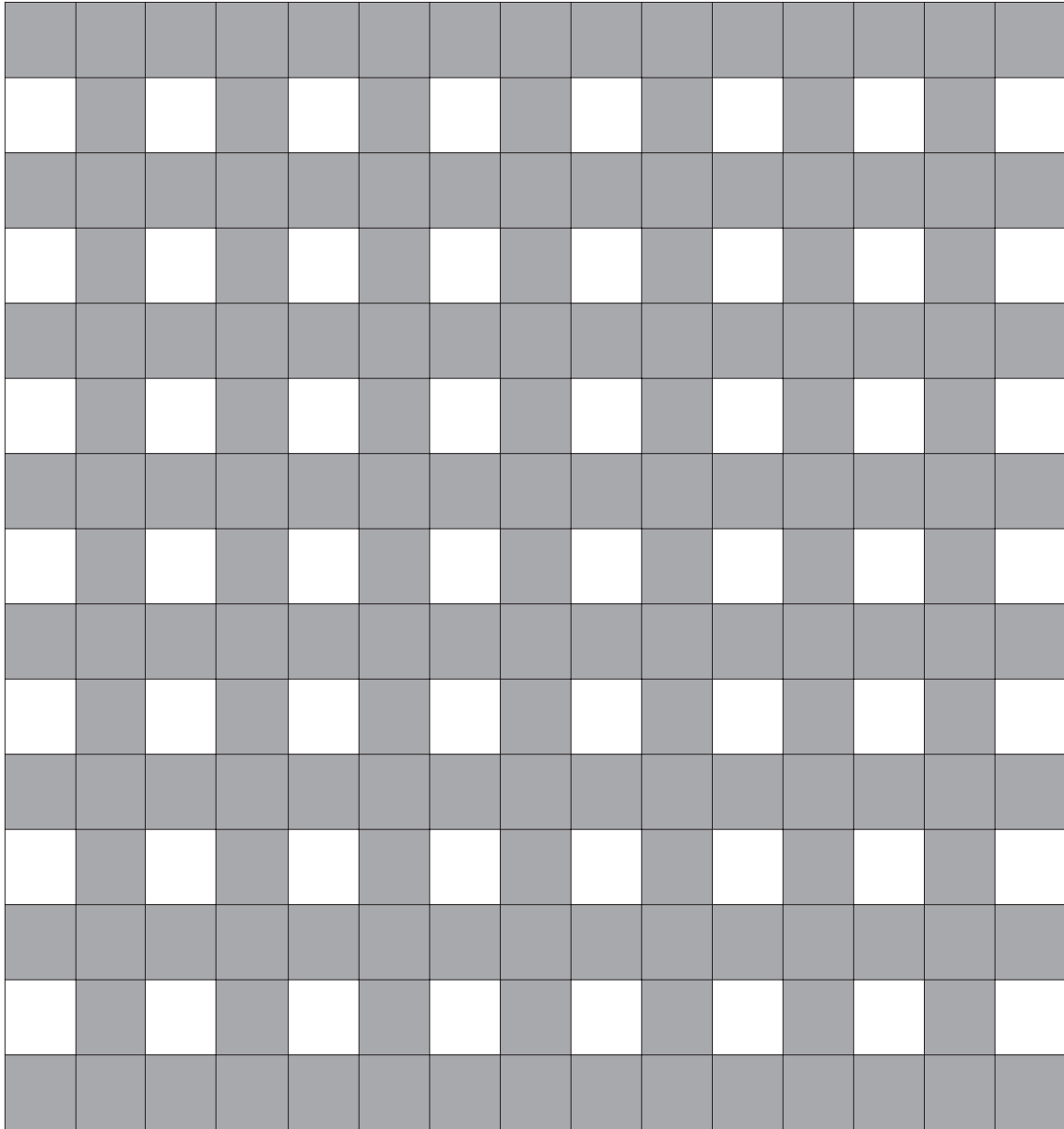

Bain bileog as do chóipleabhar suimeanna.

Cé mhéad dronuilleog éagsúil is féidir leat a dhéanamh agus 16 chearnóg in úsáid agat?

Cén t-achar atá i ngach ceann de na cruthanna seo?

Gach cearnóg – 1 cm²

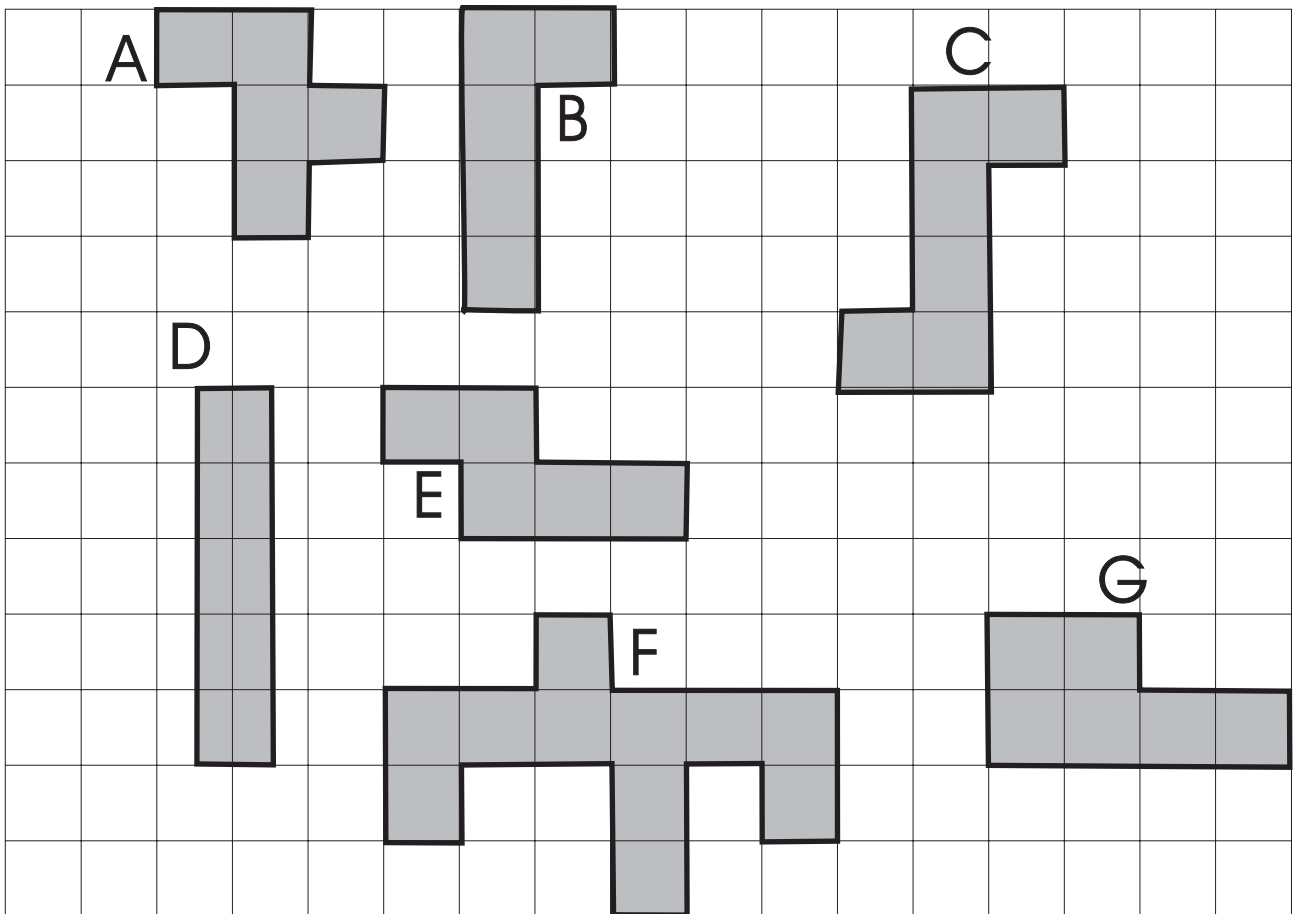

Cén airde atá ionat?

Cuimhnigh: 100 cm = 1 mhéadar

Má tá tú 150 ceintiméadar ar airde is féidir é a scríobh mar seo:

1.5 méadar.

Cén t-achar atá á chlúdach ag na cruthanna seo?

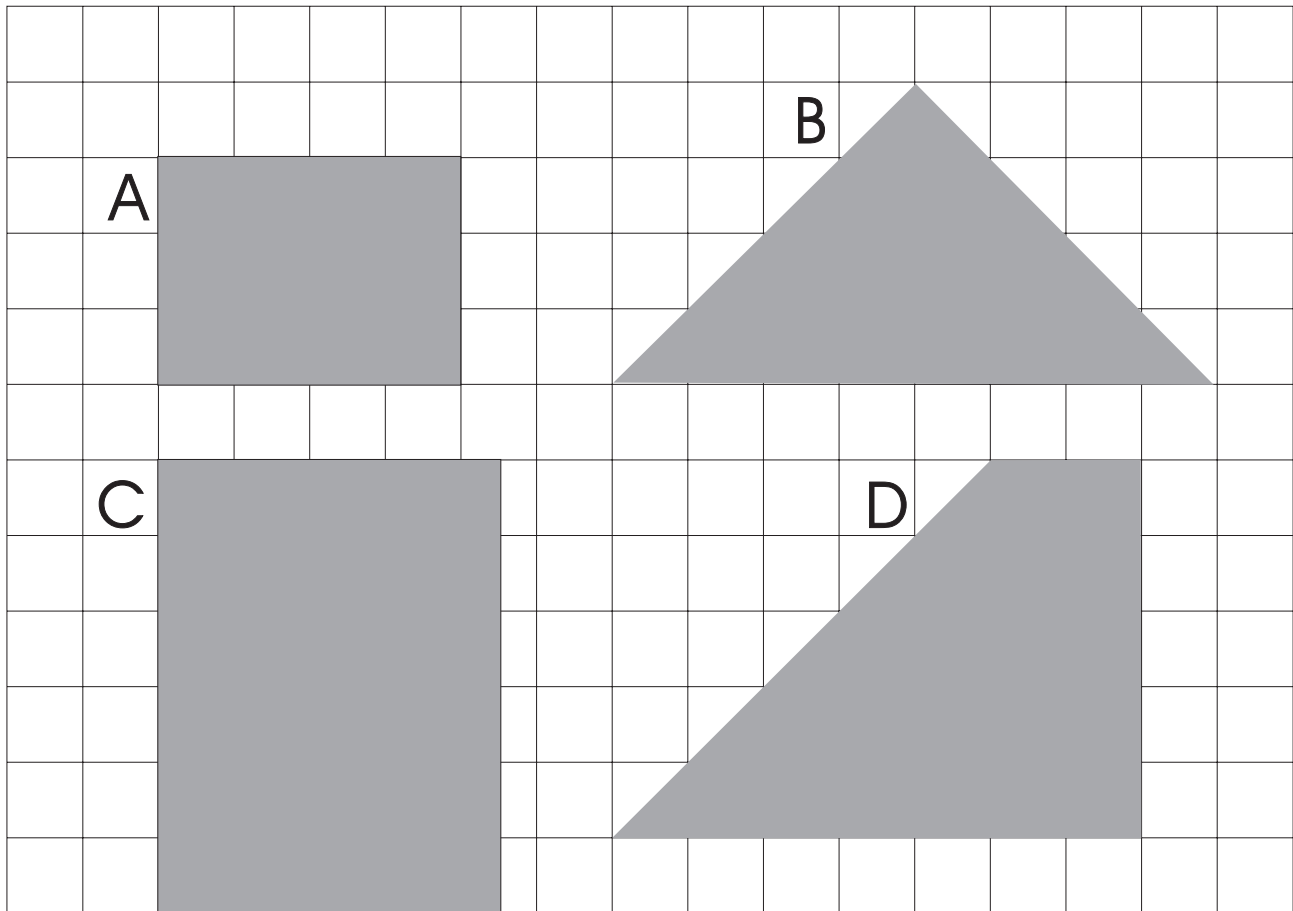

Beidh ² i ngach freagra ar shuimeanna achair.



Bíonn eolas ar channaí péinte faoin achar a chlúdóidh an péint. Abair go raibh dathadóir le ceithre bhalla foirgnimh a phéinteáil. Más é 50 m^2 (caoga méadar cearnach) achar iomlán na mballaí agus má chlúdaíonn canna péinte 18 m^2 (ocht méadar chearnacha déag), bheadh 3 channa péinte ag teastáil ón dathadóir leis an obair a dhéanamh.

Fad × Leithead = Achar

1

$$(a) \quad \begin{array}{c} \text{cm} \\ 3 \end{array} \times \begin{array}{c} \text{cm} \\ \square \end{array} = 36 \text{ cm}^2$$

$$(b) \quad \square \times 2 = 30 \text{ cm}^2$$

$$(c) \quad 15 \times \square = 45 \text{ cm}^2$$

$$(d) \quad \square \times 6 = 48 \text{ cm}^2$$

$$(e) \quad 12 \times \square = 144 \text{ cm}^2$$

$$(f) \quad \square \times 10 = 110 \text{ cm}^2$$

$$(g) \quad 6 \times \square = 54 \text{ cm}^2$$

$$(h) \quad \square \times 9 = 81 \text{ cm}^2$$

$$(i) \quad 30 \times \square = 60 \text{ cm}^2$$

$$(j) \quad \square \times 6 = 72 \text{ cm}^2$$

$$(k) \quad \square \times 8 = 72 \text{ cm}^2$$

$$(l) \quad 11 \times 7 = \square \text{ cm}^2$$

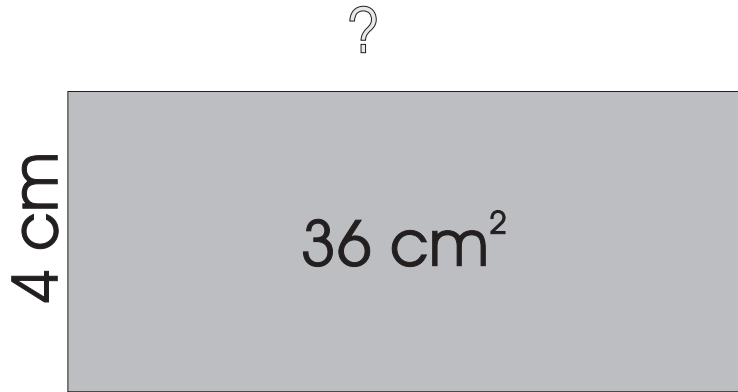

fad \times leithead = achar

$$4 \text{ cm} \times \square = 36 \text{ cm}^2$$

leithead = 9 cm

Nótáil: Níl na léaráidí anseo de réir scála.

① Faigh an leithead.

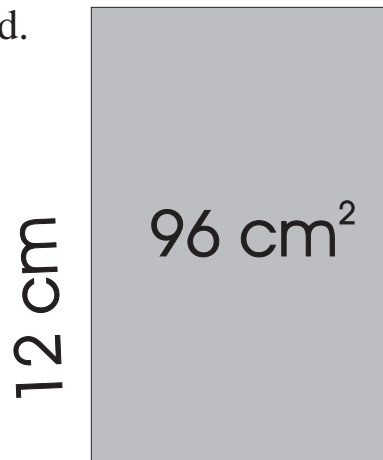

② Faigh an fad.

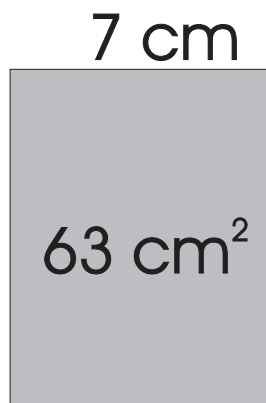

① Faigh leithead gach dronuilleoige.

- (a) achar 272 cm^2 , fad 17 cm
- (b) achar 1406 cm^2 , fad 38 cm
- (c) achar 612 cm^2 , fad 34 cm
- (d) achar 2109 cm^2 , fad 57 cm

② Faigh fad gach dronuilleoige.

- (a) achar 84 cm^2 , leithead 7 cm.
- (b) achar 234 cm^2 , leithead 13 cm.
- (c) achar 2464 cm^2 , leithead 44 cm.
- (d) achar 812 cm^2 , leithead 29 cm.

Ná
Dearmad

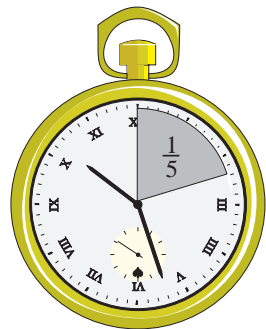

$\frac{1}{5}$ d'uair an chloig = 12 nóiméad.

Is é atá i gceist le himlíne ná timpeall an IMILL.

Tomhais an dronuilleog timpeall ar gach pictiúr thíos.

Tá ceithre thaobh nó ceithre imeall ar gach fráma

Suimigh fad na gceithre imeall le chéile, agus beidh an imlíne agat.

①



②

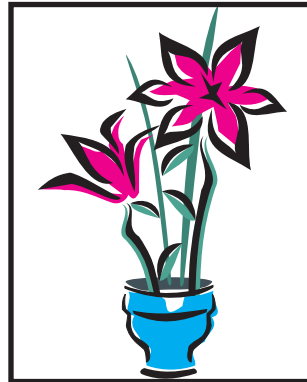

③

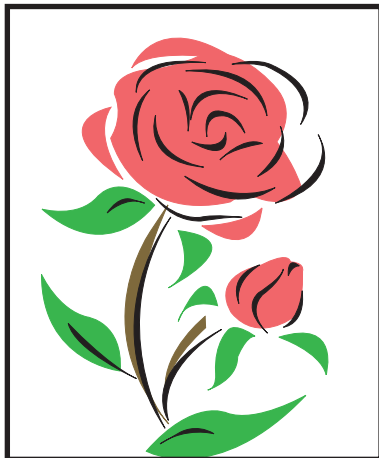

④



⑤

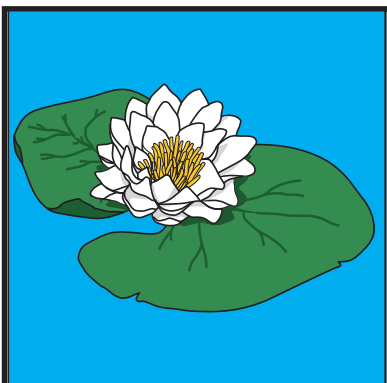

⑥



Conas a rinne tú ceist 4 ar an leathanach roimhe seo?

- An ndúirt tú:
- a) $5 + 5 + 6 + 6?$
 - b) $5 + 6 + 5 + 6?$
 - c) Dhá 5 + Dhá 6?
 - d) $(5+6) \times 2?$

Dá mba uimhreacha móra iad cén bealach ba thapúla dar leat?

Tomhais imlíne na gcruthanna seo.

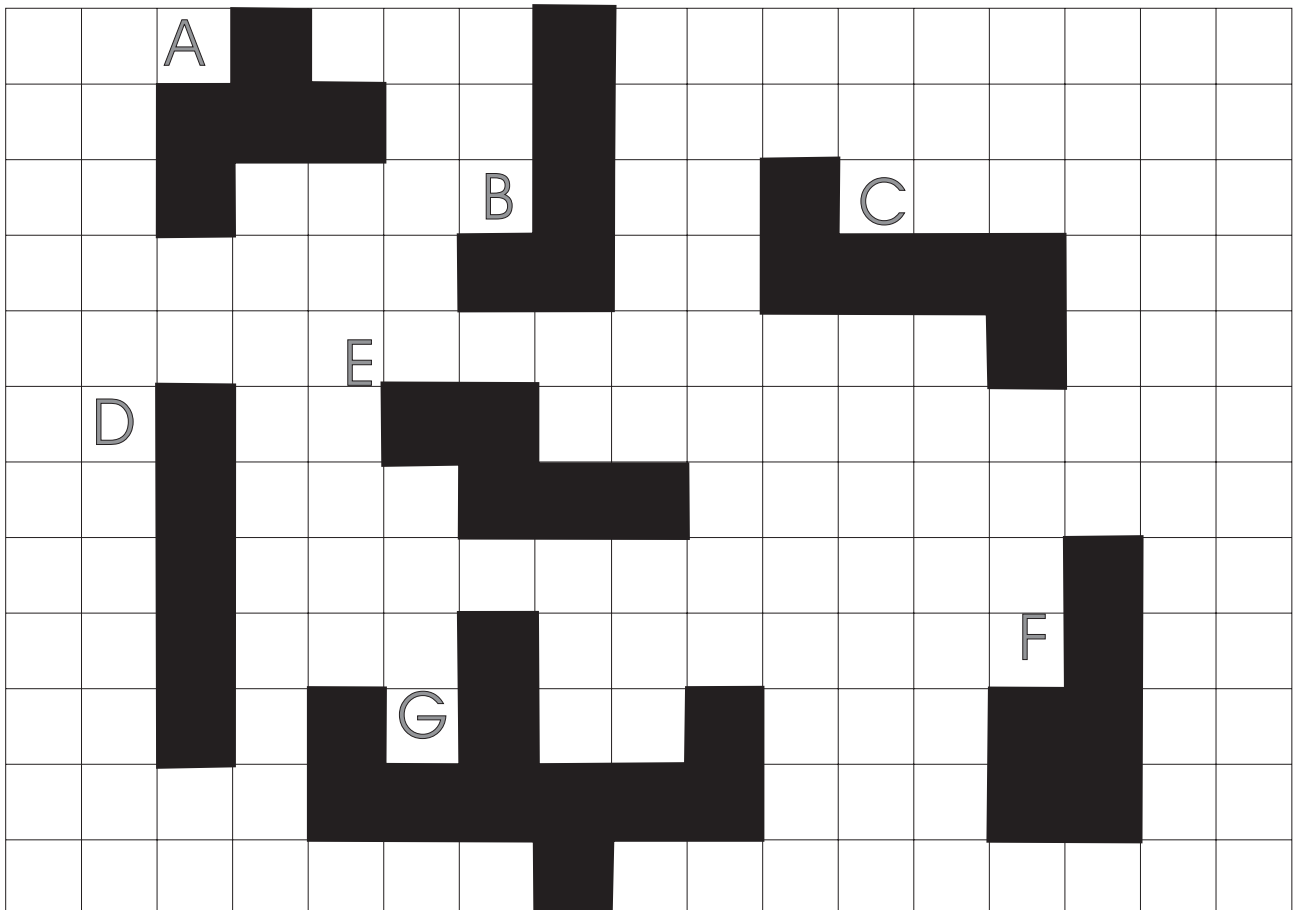

①

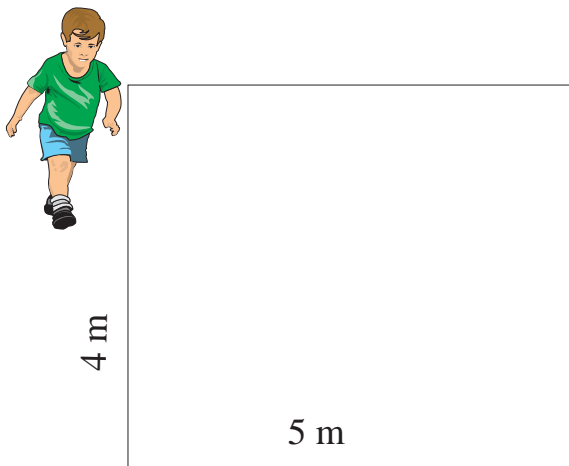

(m = méadar)

Shiúil Seán timpeall imlíne an ghairdín tosaigh. Cén fad a shiúil sé?

②

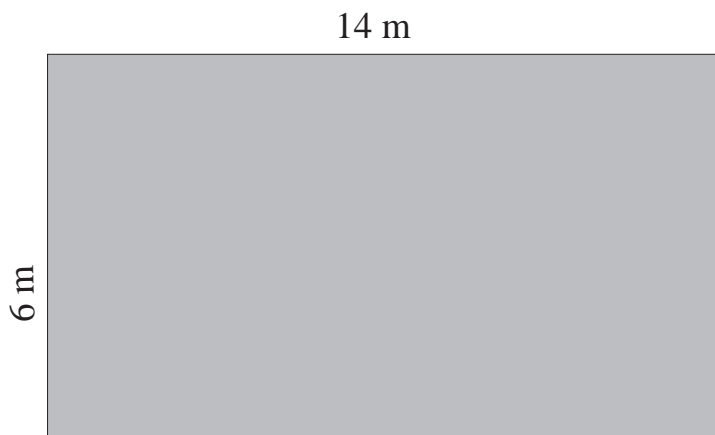

Thomhas Daidí an gairdín le fonsa nua a chur suas. Cé acu achar nó imlíne a bhí á thomhas aige? Cé mhéad sreinge a cheannaigh sé?

③

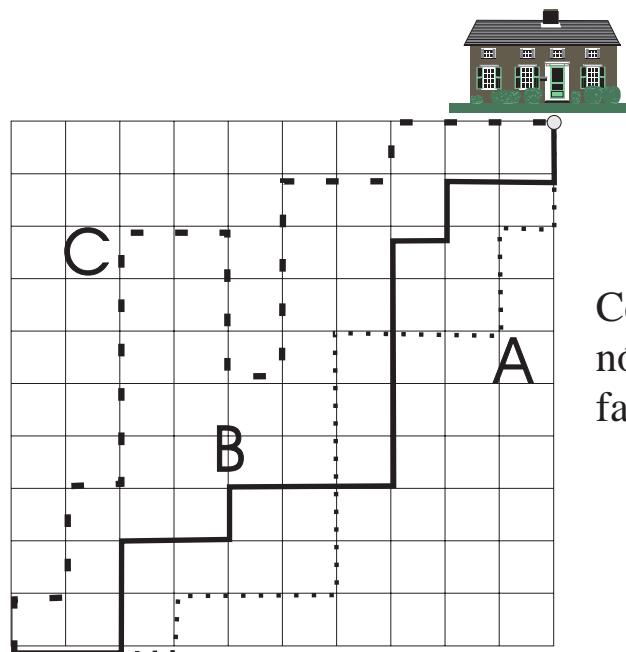

Cé acu cosán A, B, nó C an bealach is faide abhaile?

①

Gairdín atá 18 méadar ar fad agus 25 méadar ar leithead.

a) Cén t-achar atá sa ghairdín?

b) Is féidir le fear 2 m^2 a thochailt in 1 nóiméad amháin.
Cén fad ama a thógfaidh sé air an gairdín go léir a thochailt?

②

Cén t-achar atá i gcearnóg a bhfuil a taobh 6 cm ar fad?

③

Cén imlíne atá ar chearnóg a bhfuil a taobh 8 cm ar fad?

④

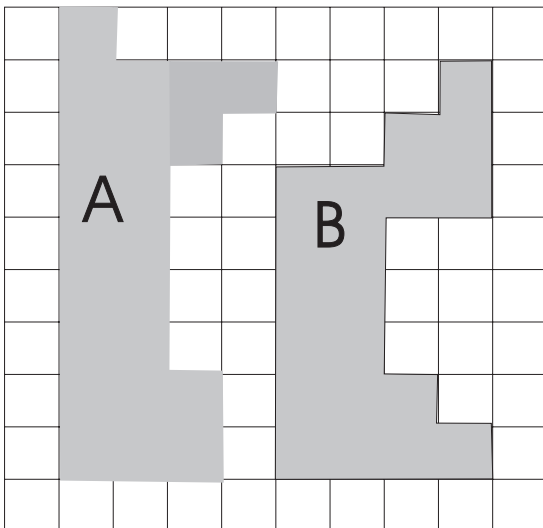

Cuir tic leis an bhfreagra ceart.

- (i) Dhá oiread achar B atá in achar A.
- (ii) Tá achar A níos lú ná achar B.
- (iii) Tá achar A níos mó ná achar B.
- (iv) An t-achar céanna atá in A agus in B.

⑤

Cé mhéad méadar rópa a theastódh ó fheirmeoir le dhá phíosa rópa a chur timpeall ar bhosca capaill dronuilleogach atá 2.3 m ar fad agus 1 m ar leithead?

⑥

Cosnaíonn cairpéad €18 an méadar cearnach. Cén costas a bheadh ar chairpéad a chlúdódh seomra 6 m faoi 4 m?

Ríomh achar na gcruthanna thíos in aonaid chearnacha.

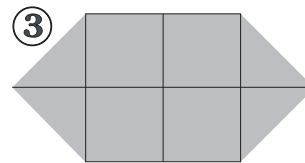
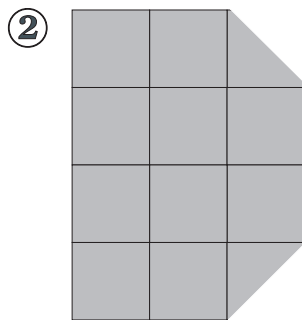

aonad
cearnach
amháin

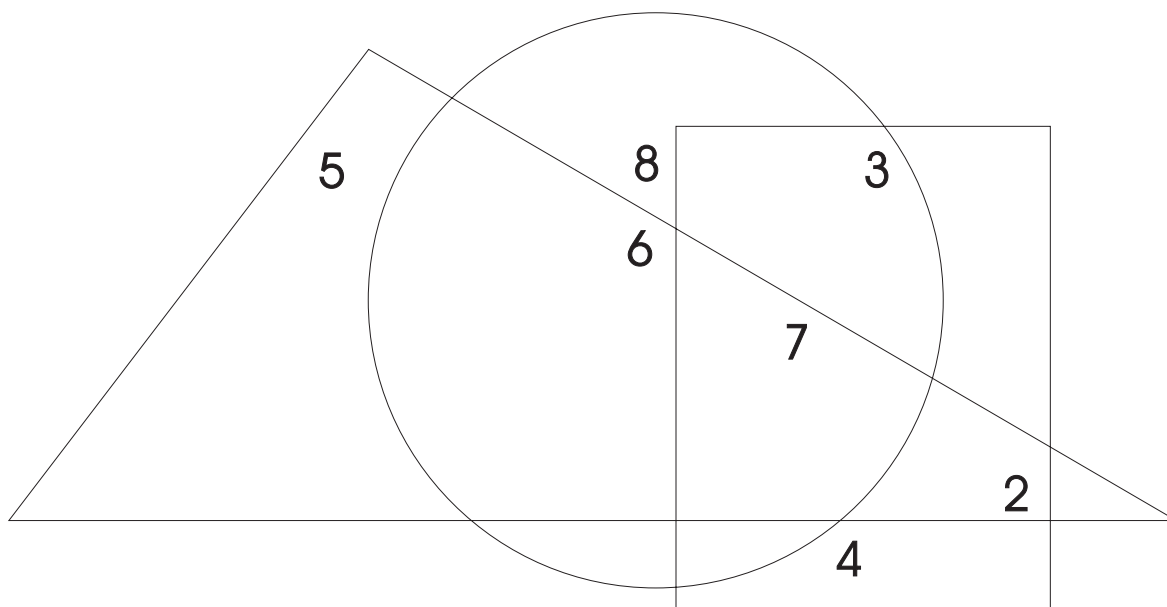

④ Cén uimhir nach bhfuil ach sa triantán amháin?

⑤ Cén uimhir nach bhfuil ach sa triantán agus sa dronuilleog?

⑥ Cén uimhir atá sna trí chruth?

⑦ Cén uimhir nach bhfuil ach sa chiorcal agus sa dronuilleog?

⑧ Cén uimhir nach bhfuil ach sa chiorcal amháin?

⑨ Cén uimhir nach bhfuil ach sa dronuilleog amháin?

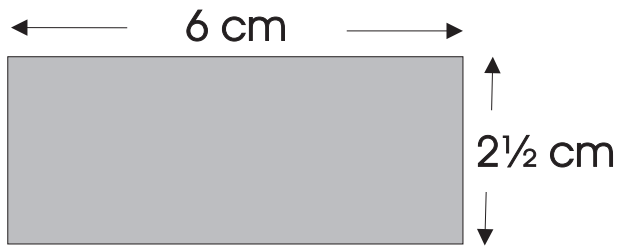

① Is é achar na dronuilleoige:

- (a) 15 cm² (b) 6½ cm² (c) 9 cm² (d) 6½ cm²

② Faigh achar an chrutha seo?

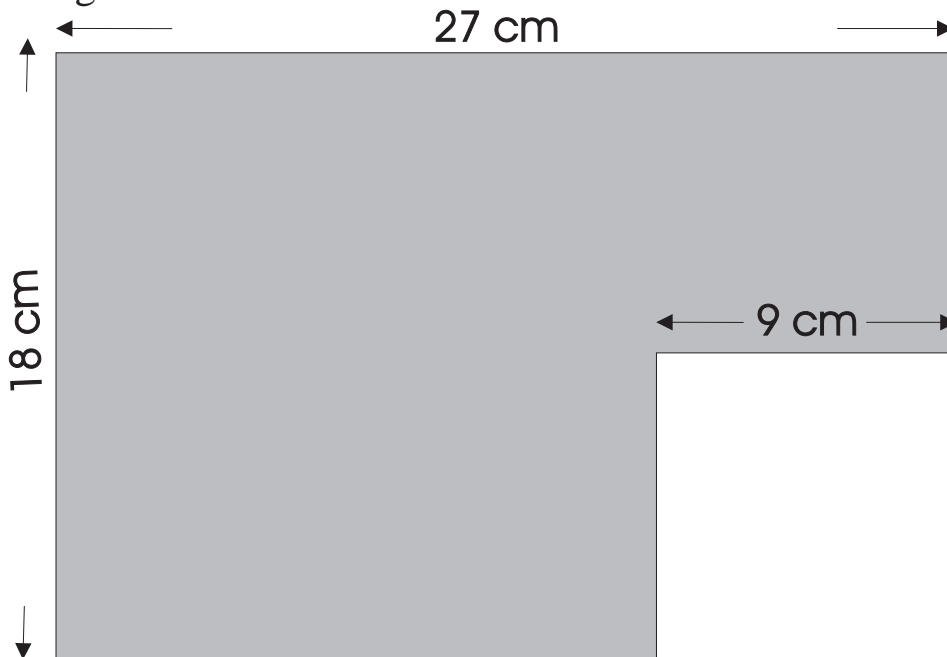

Bíonn ainmneoir coiteann ag teastáil nuair a bhíonn codáin le suimiú nó le dealú.

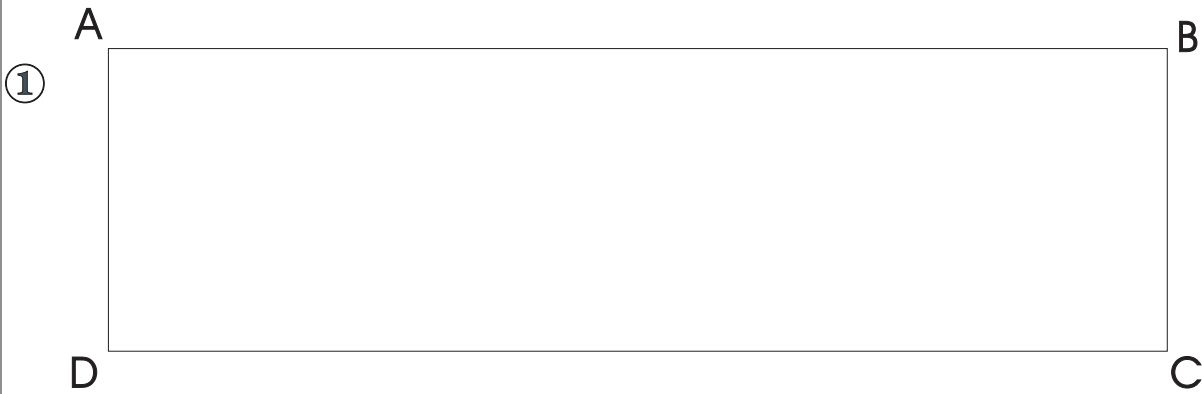

Bain úsáid as do rialóir agus tomhais sleasa na dronuilleoige seo.

AB = cm

AD = cm

Cad é achar na dronuilleoige?

Cad é imlíne na dronuilleoige?



Ríomh:

(a) achar na dronuilleoige.

(b) imlíne na dronuilleoige.

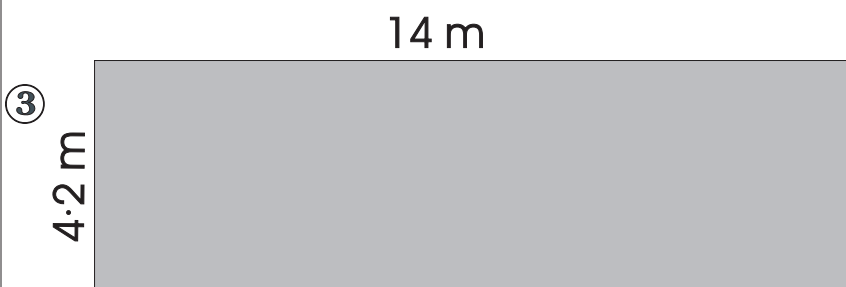

Ríomh:

(a) achar na dronuilleoige.

(b) imlíne na dronuilleoige.

Tomhais imlíne na gcruthanna seo le do rialóir.

①

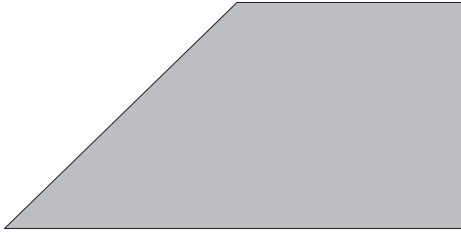

②

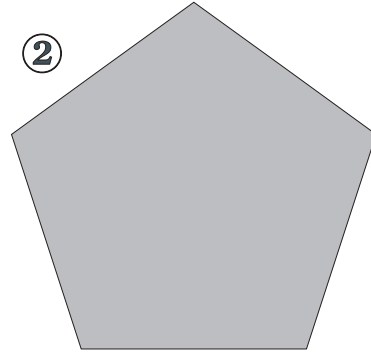

③

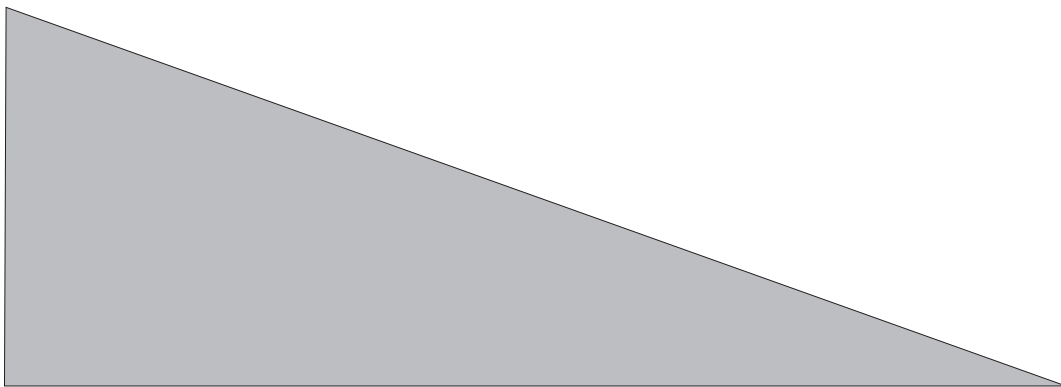

④

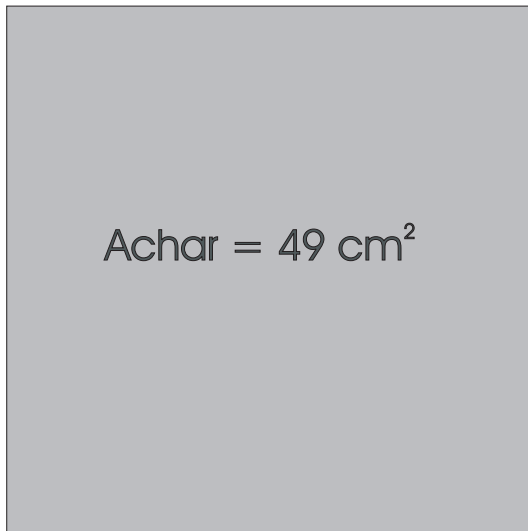

Ríomh imlíne na cearnóige.

⑤

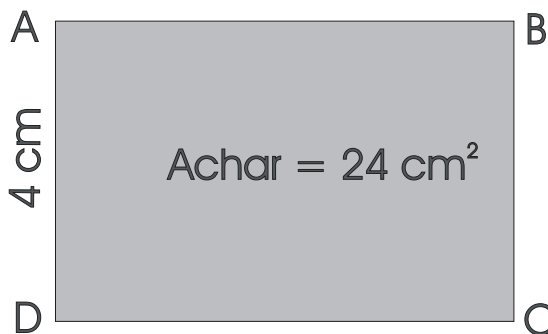

Ríomh fad AB.

Achar Triantáin

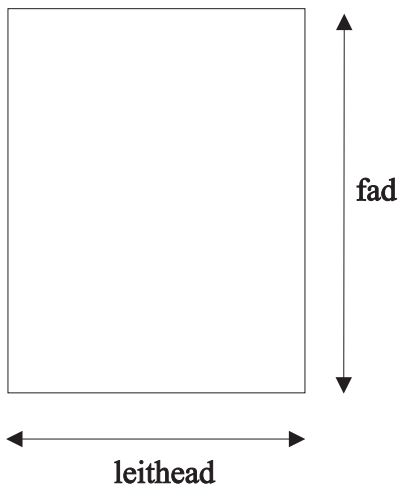

Achar cearnóige nó achar dronuilleoige =
fad \times leithead

Airde a thugtar ar an bhfad i dtriantán.

An **bonn** a thugtar ar an leithead

Achar an phársa den dronuilleog atá scáthaithe, tá sé cothrom le $\frac{1}{2}$ achar na dronuilleoige ina hiomlán.

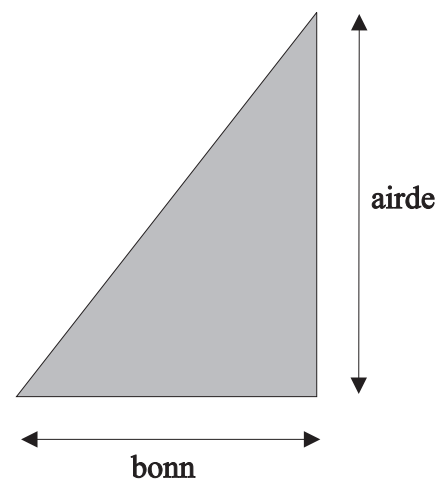
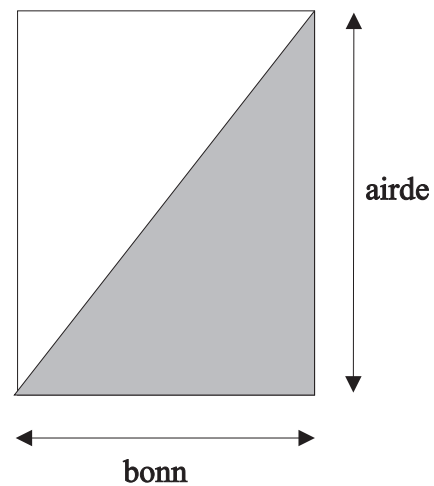

Dá réir sin: Achar triantáin = $\frac{\text{bonn} \times \text{airde}}{2}$

Ríomh achar na dtriantán.

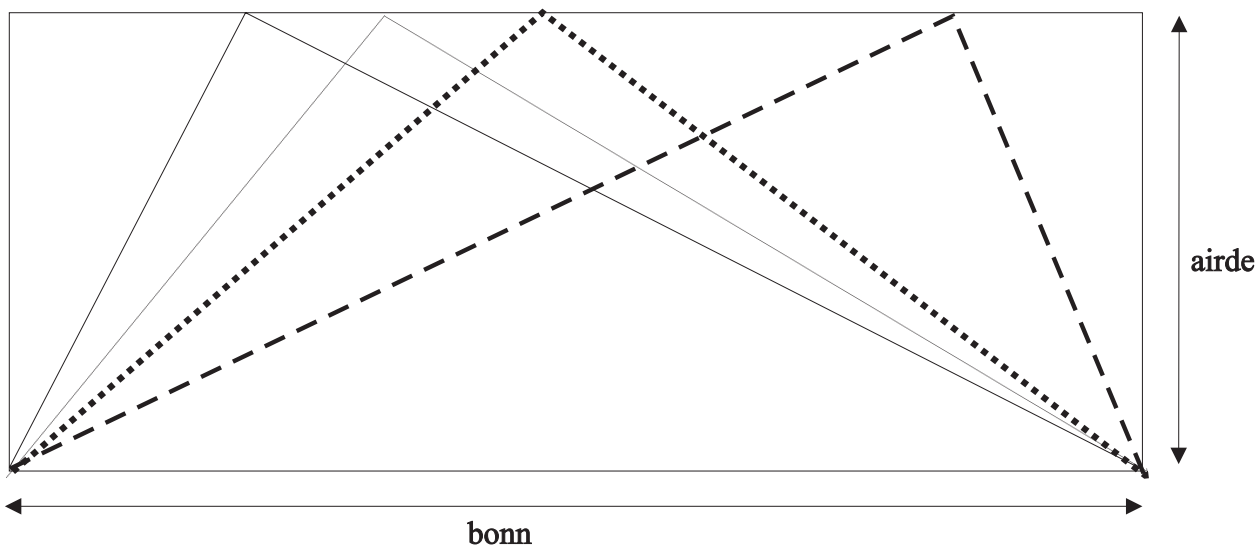
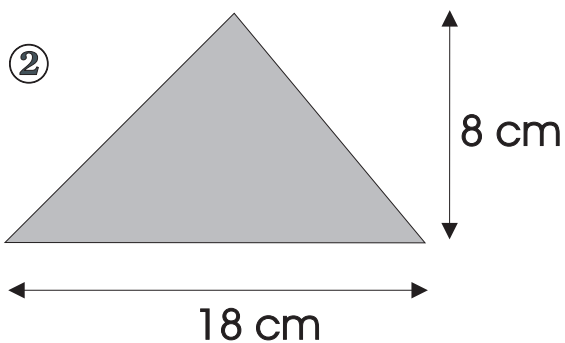
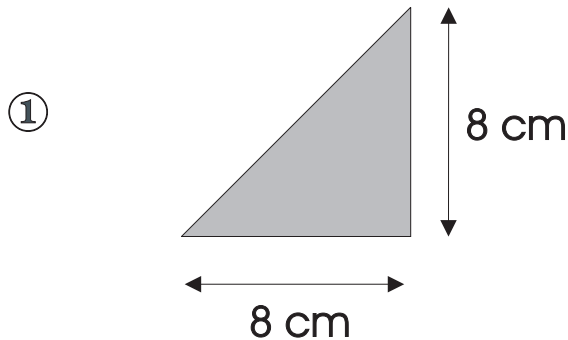

An bhfeiceann tú go bhfuil an t-achar céanna – 45 cm^2 – ag na triantáin seo go léir?

Tarraing triantán eile sa dronuilleog. Bíodh an bonn céanna ann agus an airde chéanna ann.

Cén t-achar atá ann?

Ríomh achar na gcruithanna seo.

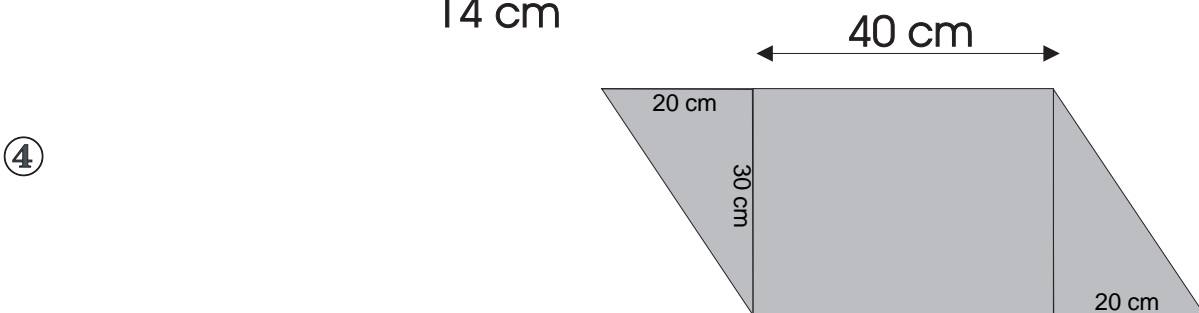
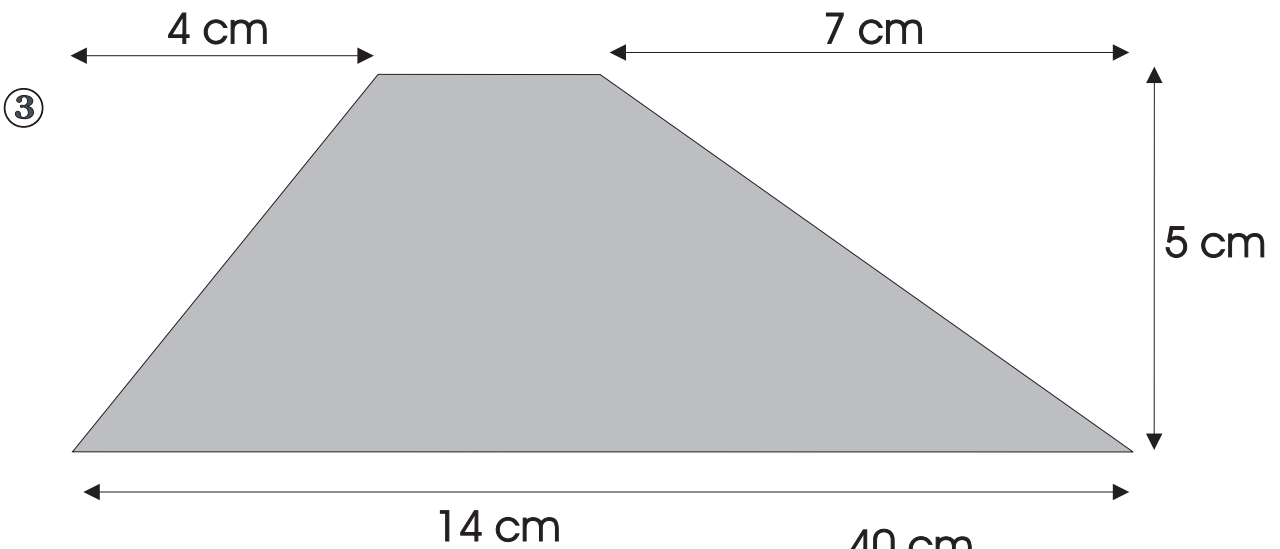
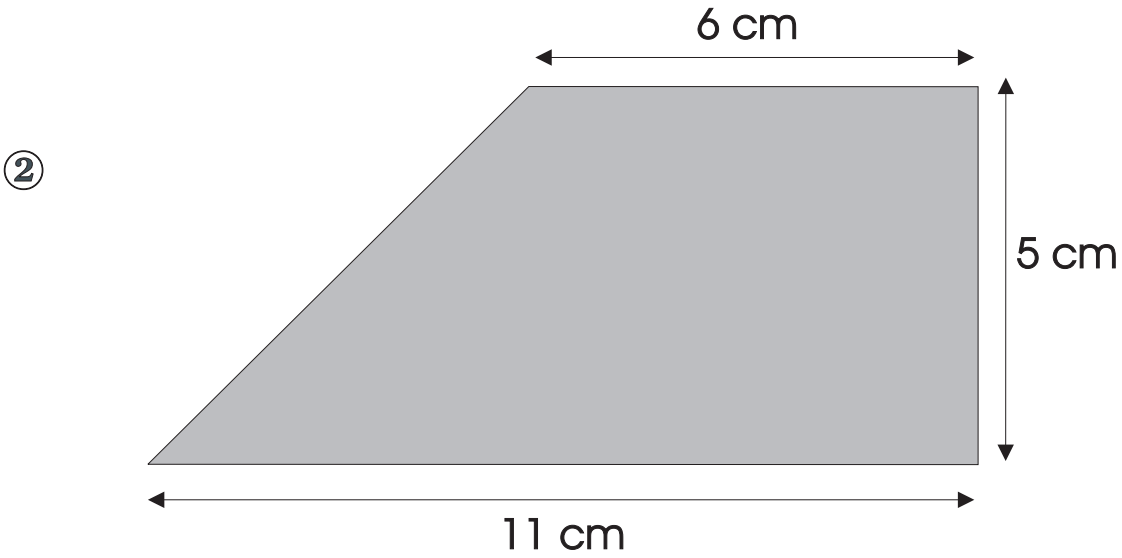
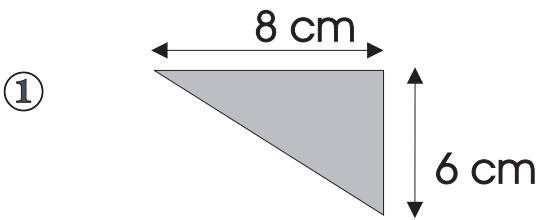

Faigh achar an ghiota atá scáthaithe.

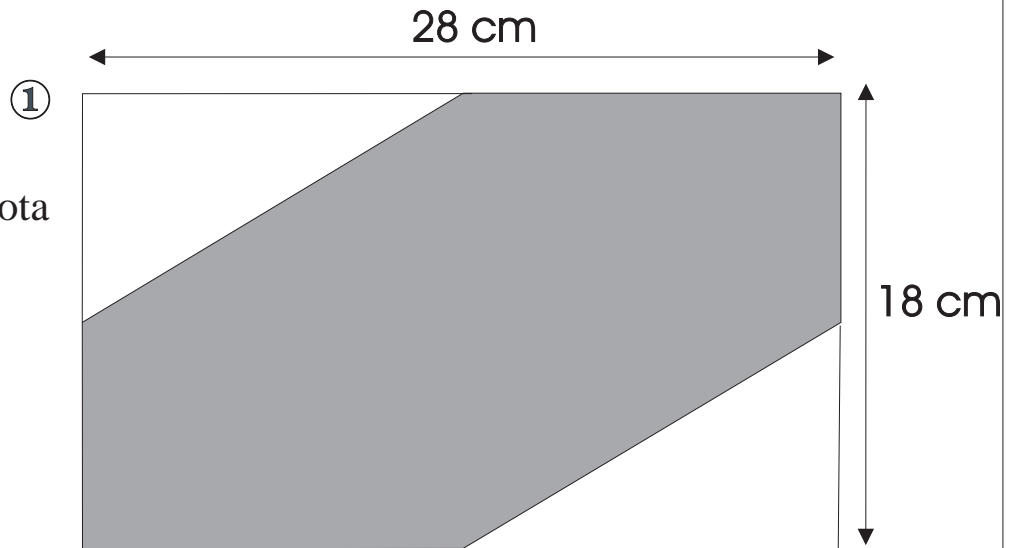

Faigh achar na gcruthanna thíos.

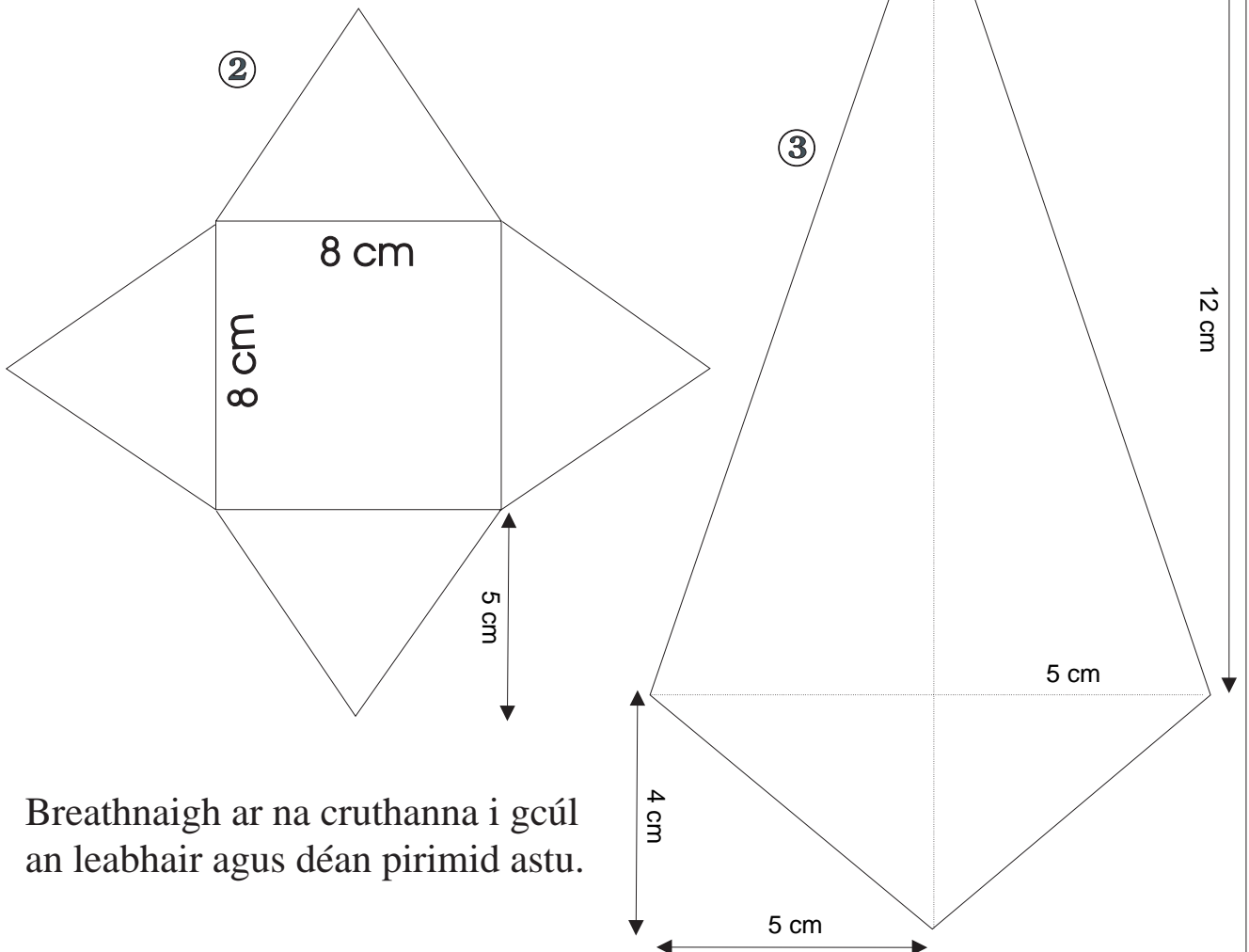

Breathnaigh ar na cruthanna i gcúl an leabhair agus déan pirimid astu.

Uillinneacha agus Línte



Líne
cheartingearach



Líne chothrománach

① Féach an dréimire seo.



(a) Cé mhéad líne cheartingearach atá ann?

(b) Cé mhéad líne chothrománach atá ann?

Éiríonn an Ghrian ag **bun na spéire**



Féach na litreacha seo

E H L T F

② Cé mhéad líne chothrománach atá sna litreacha?

③ Cé mhéad líne cheartingearach atá sna litreacha?

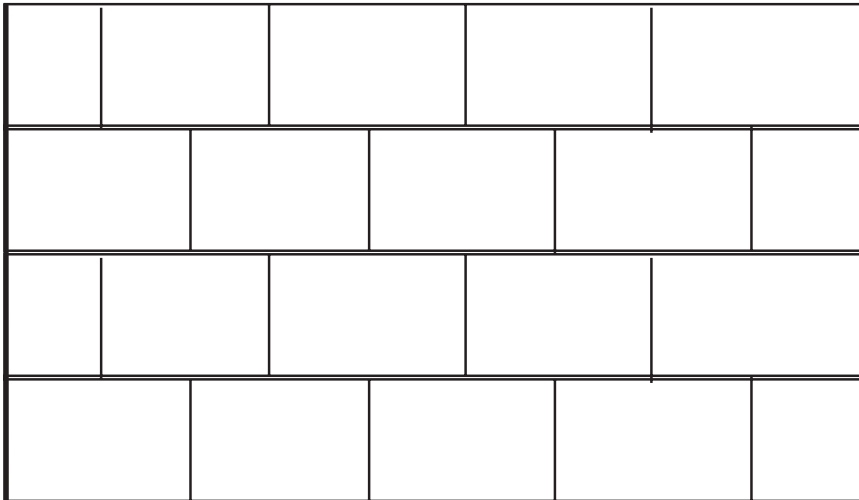

① Féach an balla seo.
Cé mhéad líne cheartingearach a fheiceann tú?



② Tá an leanbh ina luí go

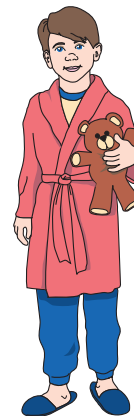

③ Tá an buachaill ina sheasamh go

Úsáideann bríceadóir leachtleibhéal leis na himill chothrománacha a sheiceáil agus úsáideann sé líne ingir leis na himill cheartingearacha a sheiceáil.





Cé mhéad líne
chothrománach atá sa
phictiúr seo?



An bhfuil simléir an tí
seo ceartingearach?



③ Cé mhéad píosa adhmaid sa
phictiúr seo atá
ceartingearach?

Cé mhéad píosa adhmaid sa
phictiúr seo atá
cothrománach?

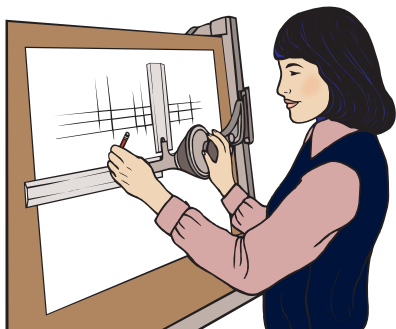

④ Cé acu líne cheartingearach nó líne
chothrománach atá á tarraingt ag an
mbean seo?

⑤ Tarraing fuinneog.
Úsáid 7 líne, 4 líne cheartingearacha agus 3 líne chothrománacha.

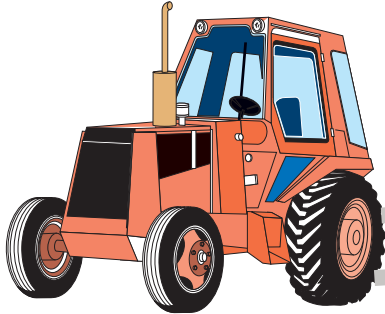

Déanann an tarracóir rianta comhthreomhara trasna na páirce.

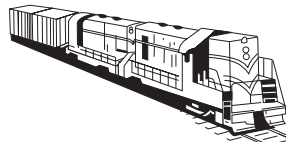

Bíonn ráillí an iarnróid comhthreomhar.



Níl an dá líne seo comhthreomhar.



Fachtóirí 45 iad 5 agus 9

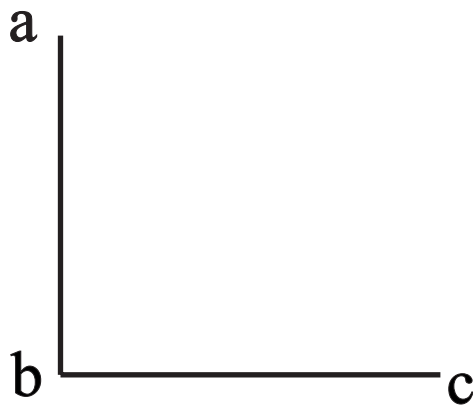

- ① Líne í an líne **bc**.
- ② Líne í an líne **ab**.

Is féidir a rá, chomh maith,

go bhfuil an líne **ab** ingearach leis an líne **bc**

agus

go bhfuil an líne **bc** ingearach leis an líne **ab**.

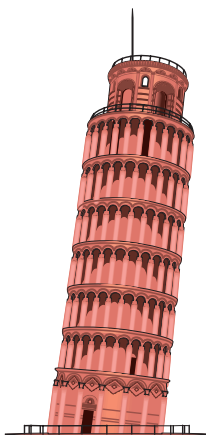

Tá foirgneamh cáiliúil san Iodáil
ar a dtugtar Túr Claonta Pisa.
Níl sé ceartingearach leis an talamh.

Línte Comhthreomhara a Tharraingt

Modh 1

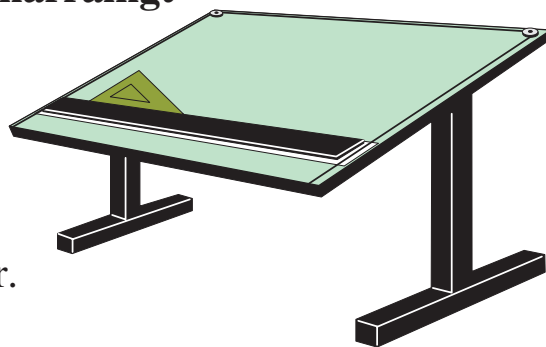

Tarraing líne dhíreach ar bith xy le do rialóir.

(Bíodh xy ina treoirlíne ag do rialóir).

Leag imeall an rialóra feadh na líne xy atá tarraingthe agat.

Cuir do dhronbhacart mar atá sa léaráid thíos. Bíodh imeall amháin leis an rialóir.

Ná lig don dronbhacart sleamhnú. Féadfaidh tú oiread línte agus is mian leat a tharraingt ach an dronbhacart a bhogadh feadh na líne xy .

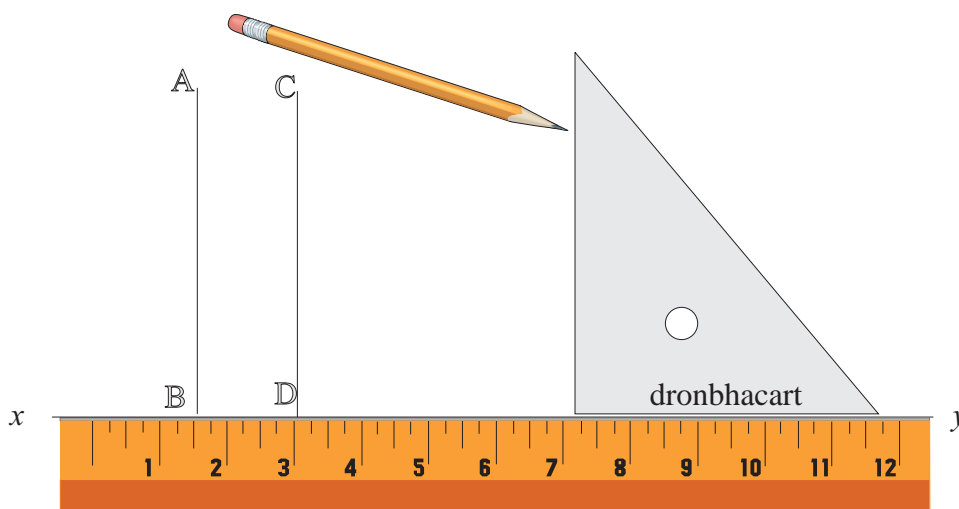

Tá na línte AB agus CD comhthreomhar lena chéile.

- ① Tarraing líne ar fiar agus í 9 cm ar fad. Úsáid do rialóir agus do dhronbhacart agus tarraing líne a bheidh comhthreomhar léi agus 3 cm uaiti.
- ② Tarraing líne 10 cm ar fad. Úsáid do dhronbhacart agus do rialóir agus tarraing ceithre líne a bheidh ingearach léi (dhá ingear ar gach aon taobh den líne).
- ③ Tarraing líne 7 cm ar fad. Ag dhá cheann na líne tarraing línte ingearacha a bheidh 7 cm ar fad. Ceangail críochphointí na línte sin. Cén saghas crutha atá déanta agat?
- ④ Gearr amach an cruth ciúbóideach i gcúl an leabhair seo. Úsáid mar **theimpléad** é agus gearr amach cruth cairtchláir as bosca gránach bricfeasta.

Déan ciúbóideach.

(i) Cé mhéad aghaidh (taobh) atá air?

(ii) Cé mhéad dronuillinn atá ann?

Línte Comhthreomhara a Tharraingt

Modh 2

Tarraing líne xy .

Tarraing dhá leathchiorcal chothroma ar an líne xy .

Tarraing líne pq a bhuaileann leis na leathchiorcail ach nach ngearrann iad.

Tá an líne pq comhthreomhar leis an líne xy .

Nótaíl: Bíodh lárphointe gach ciorcal ar an líne xy .

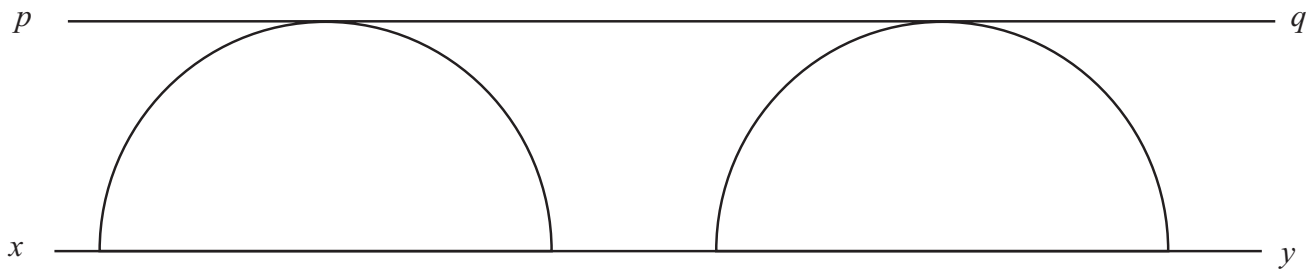

Tarraing líne 10 cm ar fad. Tugaimis ab uirthi. Bain úsáid as **Modh 2** agus tarraing líne atá comhthreomhar le ab . Bíodh sí 4 cm ón líne ab .

Tarraing líne ar fiar agus í 9 cm ar fad. Bain úsáid as **Modh 2** agus tarraing líne atá comhthreomhar léi. Bíodh an dara líne 3 cm ón gcéad líne.

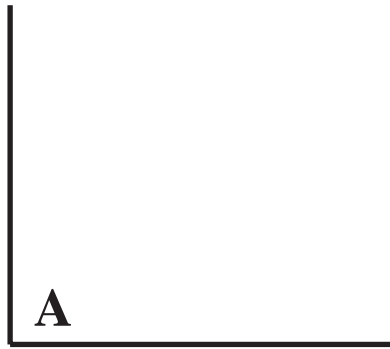

Dhá líne a bhuaileann le chéile agus a dhéanann dronuillinn áit a mbuaileann siad le chéile, deirimid go bhfuil siad ingearach le chéile.

90° (nócha céim) a bhíonn i ndronuillinn. Is dronuillinn í an uillinn **A** ar chlé.

①



Cuir tic leis na dronuillinneacha thuas.

Cé mhéad acu atá ann?

②

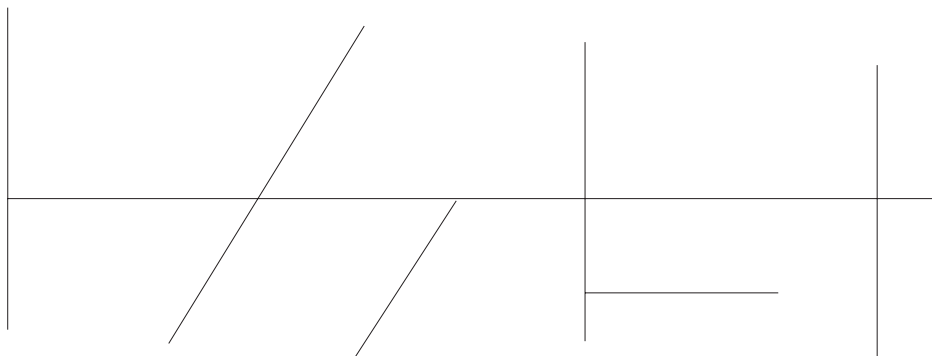

Cé mhéad dronuillinn atá sa léaráid seo?

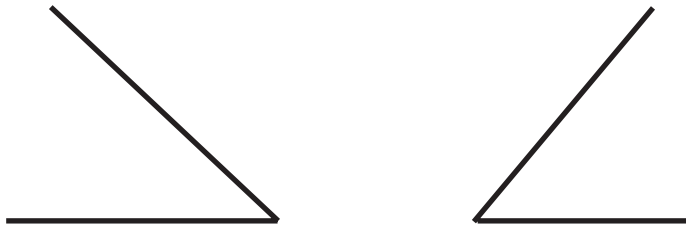

Nuair a chlaonann tú chun tosaigh i do chathaoir déanann tú géaruillinn.



①



Cuir tic leis na géaruillinneacha thuas.

Cé mhéad díobh atá ann?



géaruillinn

níos lú ná 90°

Uillinn atá níos mó ná dronuillinn, tugtar maoluillinn uirthi.

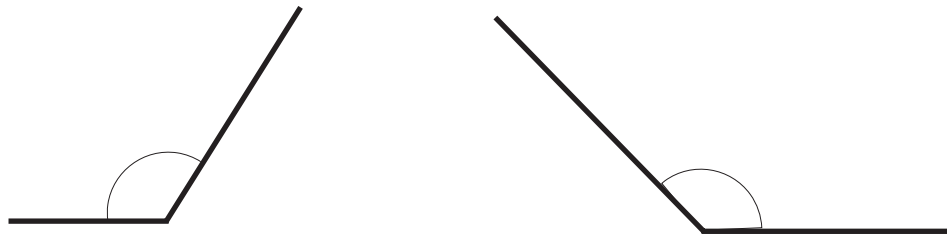

1



Cuir tic leis na maoluillinneacha thuas.

Cé mhéad díobh atá ann?

2

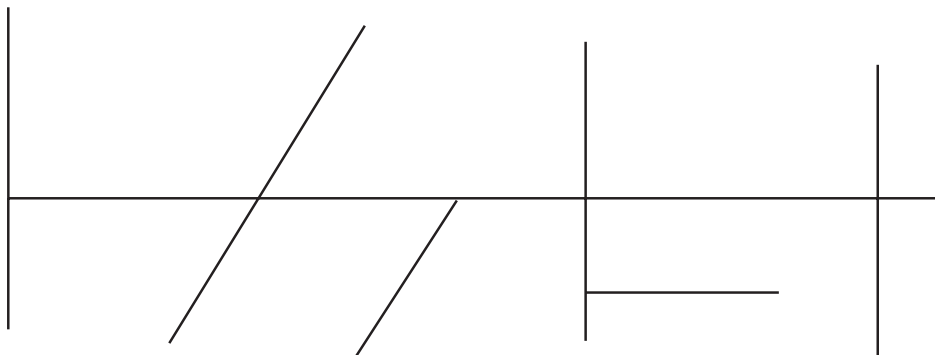

Cé mhéad maoluillinn atá sa léaráid seo?



Ní uillinn níos mó í, fiú má tá na línte níos faide.

90°

90°

Línte a thrasnaíonn a chéile

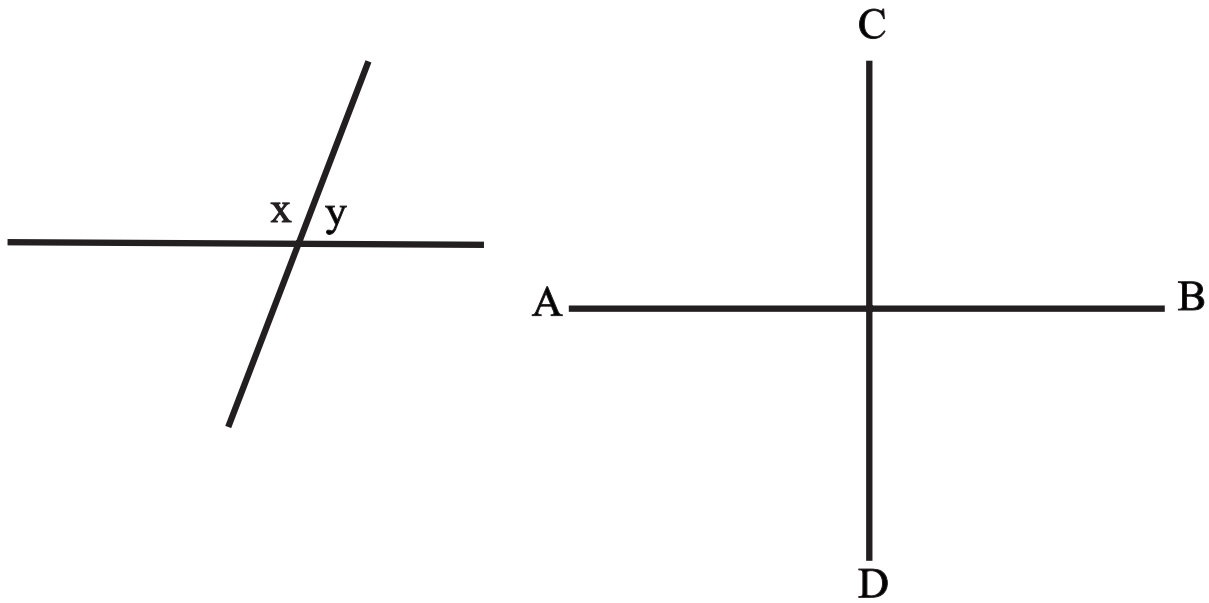

① Cé mhéad dronuillinn is féidir leat a aimsiú thuas?

② Cuir tic ✓ sa bhosca ceart.

Maoluillinn

Géaruillinn

Dronuillinn

atá in uillinn x thuas.

③ Is

maoluillinn

géaruillinn

dronuillinn

atá in uillinn y thuas.

Úsáid do dhronbhacart chun an freagra a fháil.

Uillinneacha Athfhillteacha

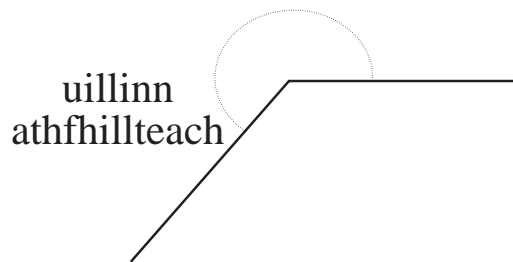
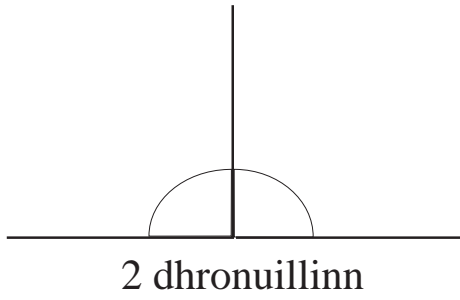

Bíonn uillinn athfhillteach níos mó ná dhá dhronuillinn ach níos lú ná 4 dhronuillinn.

Cén saghas uillinne é gach ceann de na huillinneacha seo?

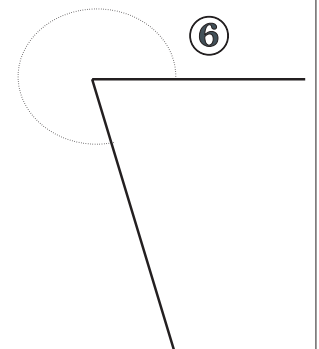
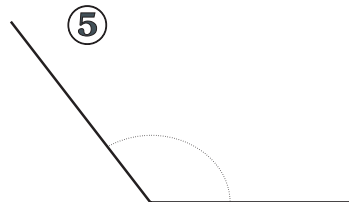
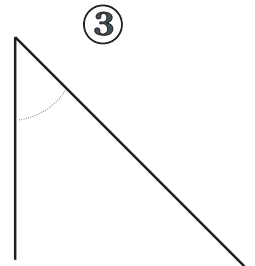
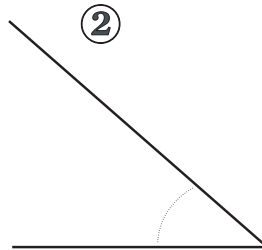
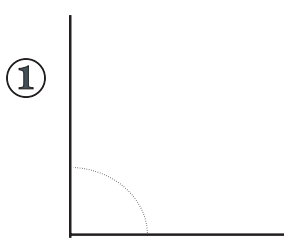

Déan garmheastachán ar mhéid gach uillinne díobh seo.

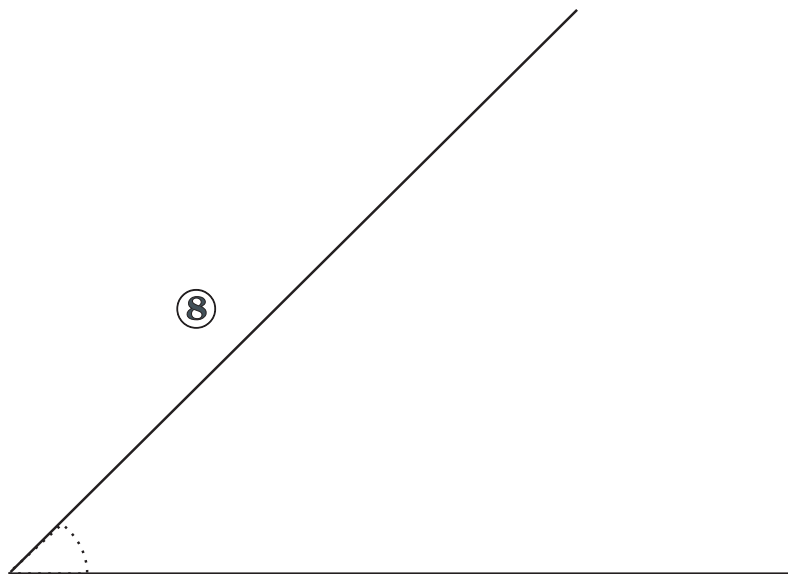
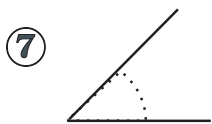
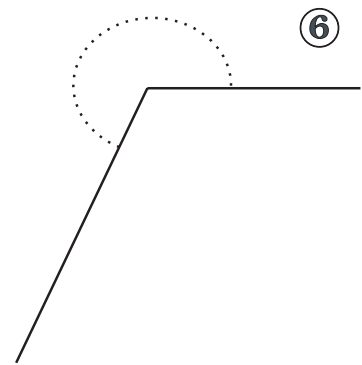
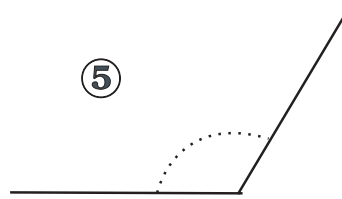
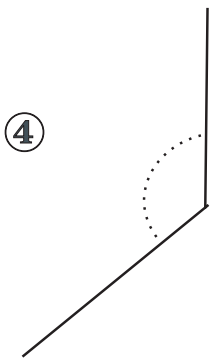
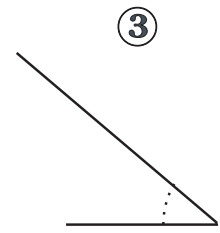
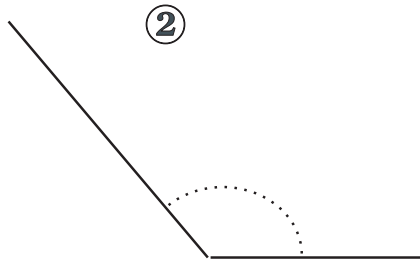
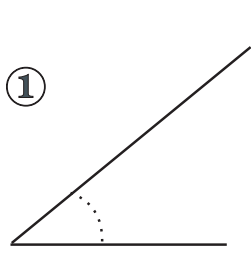

9

An bhfuil aon bhaint ag fad na línte le méid na huillinne?

Ainmnigh na huillinneacha géaruillinn, dronuillinn nó maoluillinn.

(Tá an freagra ar an gcéad cheann scríofa isteach mar eiseamláir).

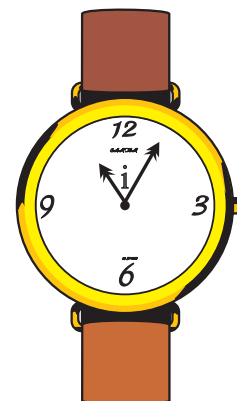
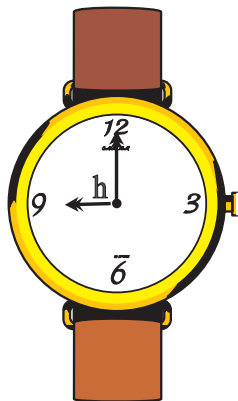
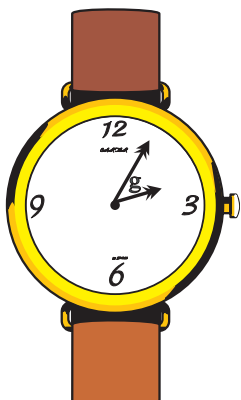
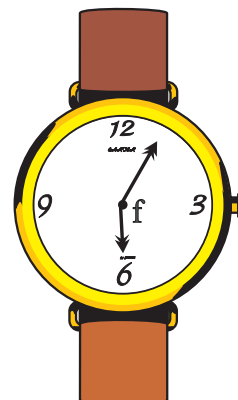
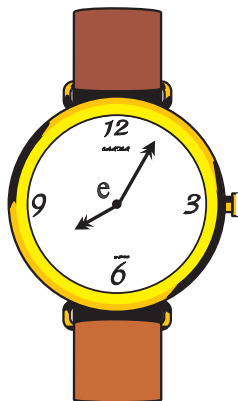
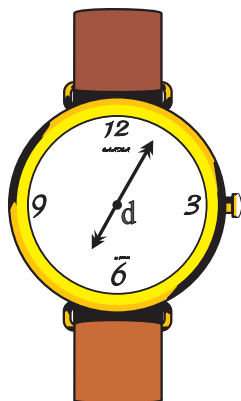
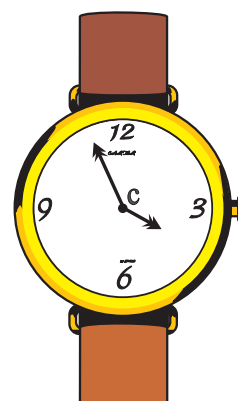
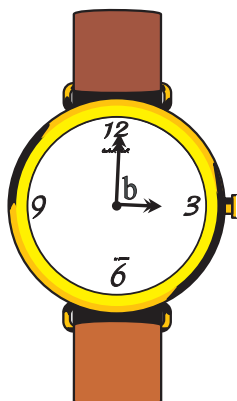
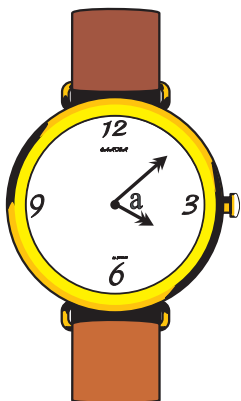

a = géaruillinn

b = uillinn

c = uillinn

d = uillinn

e = uillinn

f = uillinn

g = uillinn

h = uillinn

i = uillinn

Deiseal a théann na lámha timpeall ar chlog.

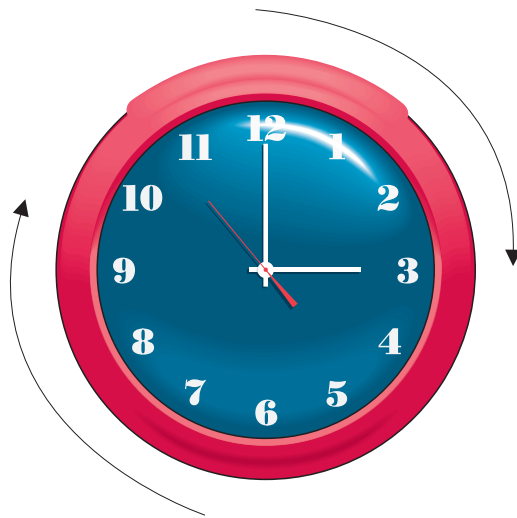

Cuireann an lámh fhada casadh iomlán amháin (360°) di in imeacht aon uair an chloig

Cé mhéad céim a chuireann an lámh fhada di in imeacht:

- (1) 15 nóiméad?
- (2) 5 nóiméad?
- (3) 50 nóiméad?
- (4) 45 nóiméad?

Cineálacha Uillinneacha:

Dronuillinn: 90° an ceathrú chuid de chasadh iomlán

Uillinn Dhíreach: 180° leathchasadh.

Géaruillinn: idir 0° agus 90°

Maoluillinn: idir 90° agus 180°

An tUillinntomhas

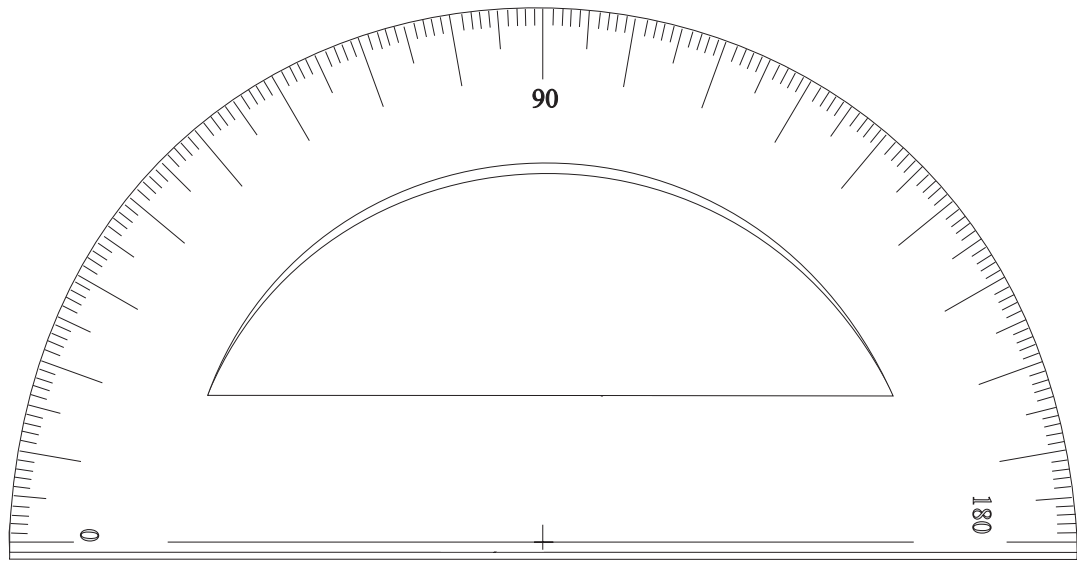

Uirlis le huillinneacha a thomhas is ea uillinntomhas. Is féidir le huillinntomhas uillinneacha a thomhas idir 0° agus 180°.

Tomhais na huillinneacha seo a leanas.
Bain úsáid as an uillinntomhas.

①

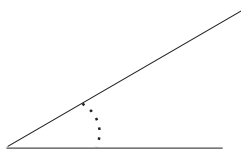

②

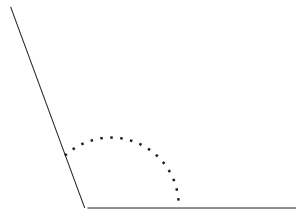

③

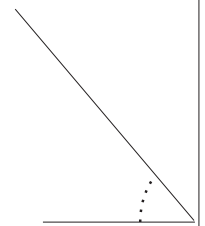

④

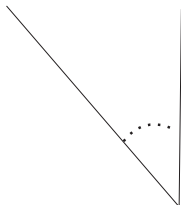

⑤

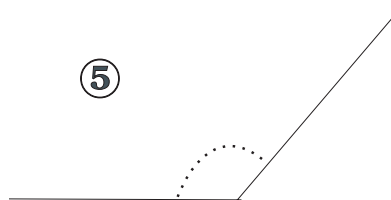

⑥

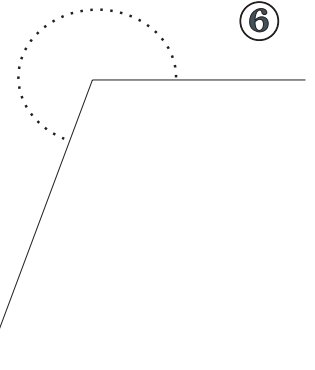

Ríomh méid na huillinne x i ngach ceann de na léaráidí thíos.

Ná húsáid d'uillinntomhas.

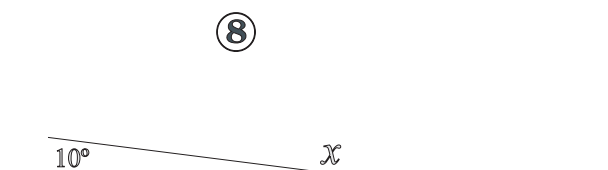
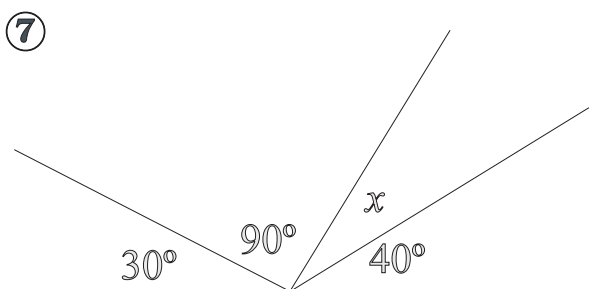
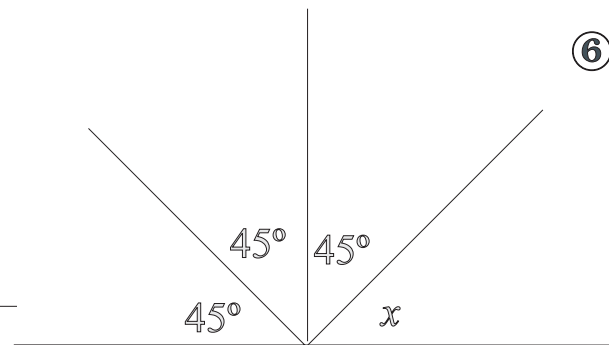
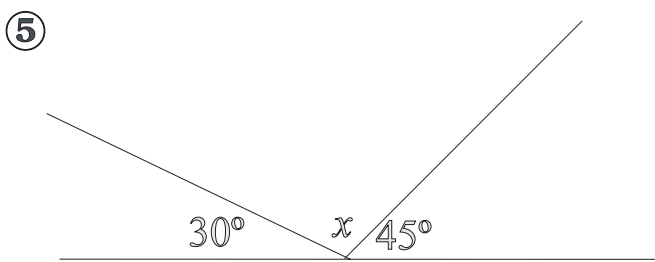
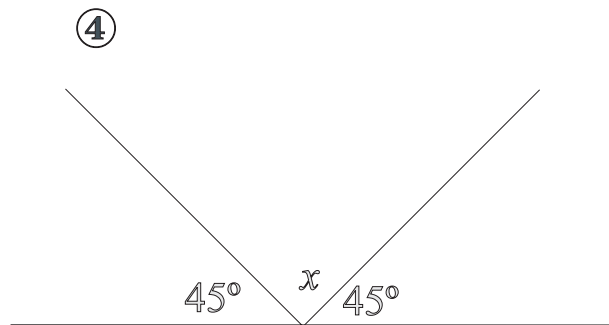
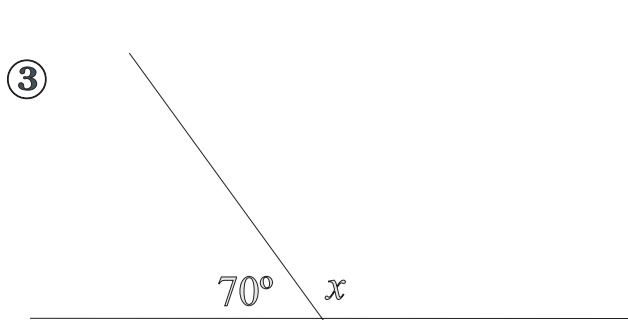
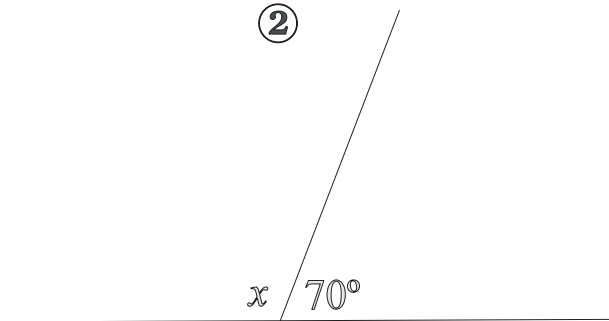
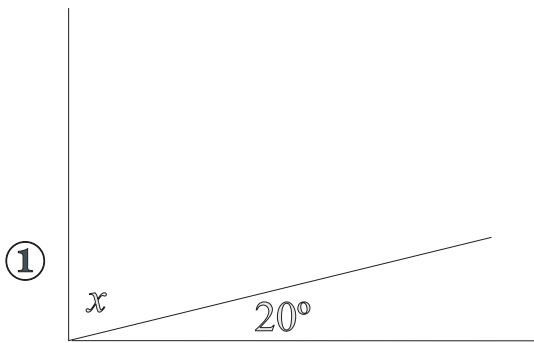

Ríomh méid na huillinne x i ngach ceann de na léaráidí thíos.

Ná húsáid d'uillinntomhas.

①

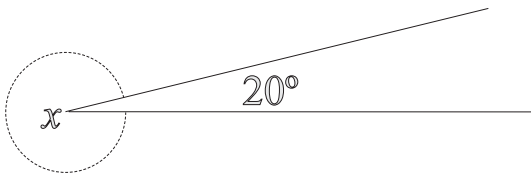

②

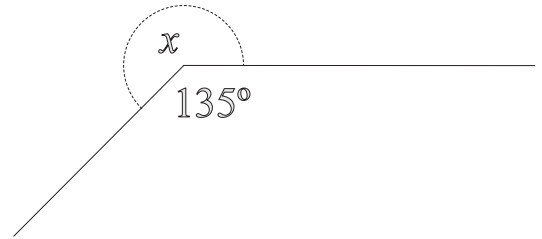

③

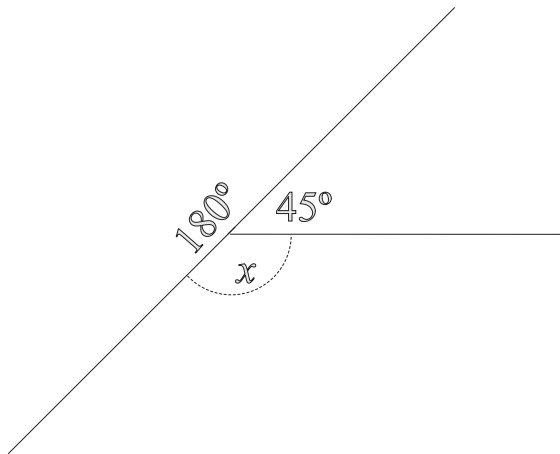

④

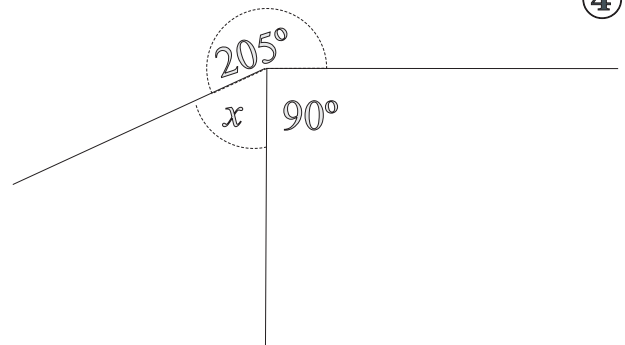

⑤

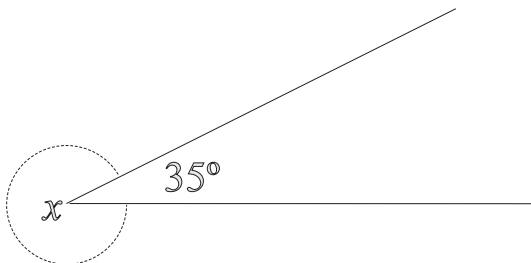

⑥

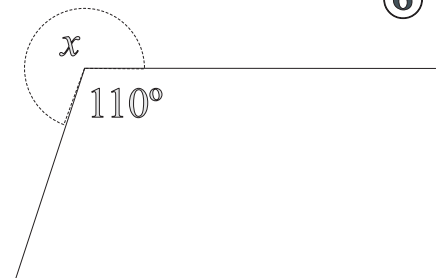

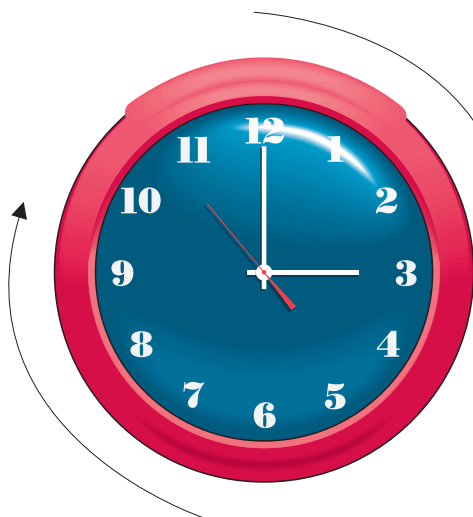

Taispeánann na saigheada treo gluaiseachta lámha an chloig.

Sin gluaiseacht dheisealach.

Gluaiseacht thuathalach a thugtar ar ghluaiseacht sa treo eile.

Ritheann lúthchleasaithe tuathal timpeall raoin reatha.

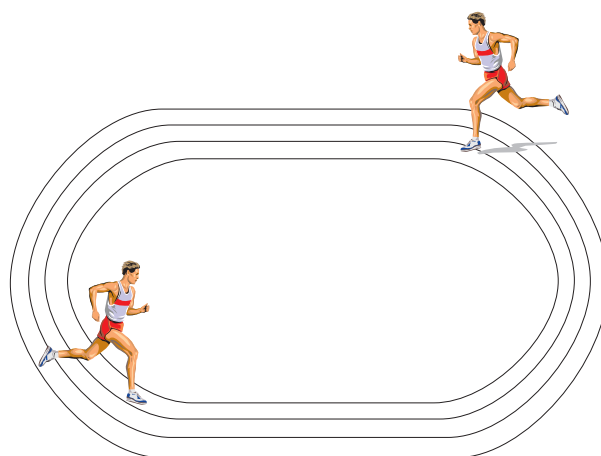

An Compás

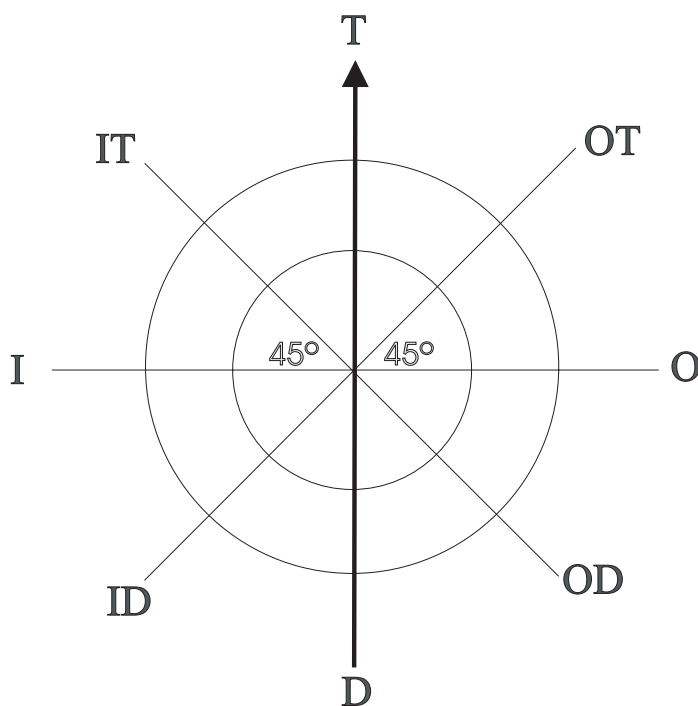

Taispeánann an compás na hairde Ó thuaidh, Soir ó thuaidh, Soir etc.

Príomhairde an Chompáis: Tuaisceart, Deisceart, Oirthear, Iarthar

An féidir leat leanúint ar aghaidh?

- Ó thuaidh (T)
- Soir (O)
- Ó dheas (D)
- Siar (I)

①

Tá mé ag breathnú Soir.

Cén treo ina mbeinn ag breathnú dá gcasfainn deiseal de:

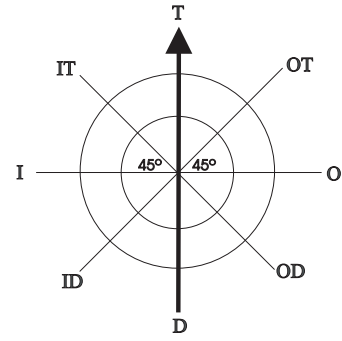

- (a) 45° (b) 225° (c) 180°
 (d) 360° (e) 135° (f) 720°

②

Tá mé ag breathnú Ó Thuaidh.

Cén treo ina mbeinn ag breathnú dá gcasfainn tuathal de:

- (a) 45° (b) 225° (c) 180°
 (d) 360° (e) 135° (f) 720°

③

Tá seacht bpionna dhubha sa bhord seo. Cas an bord deiseal de dhronuillinn amháin. Ansin tarraing na pionnaí dubha ina suíomh nua ar an mbord.

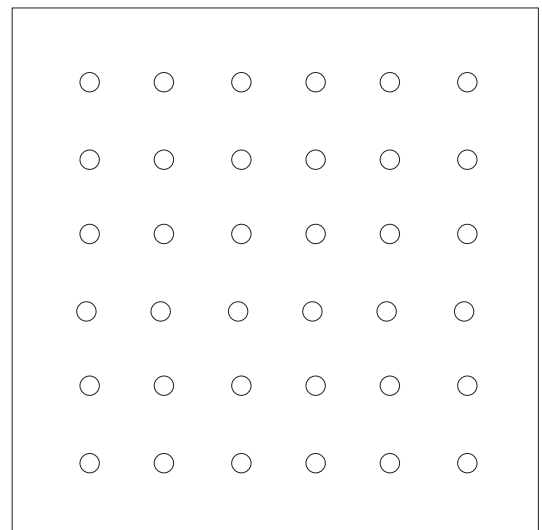
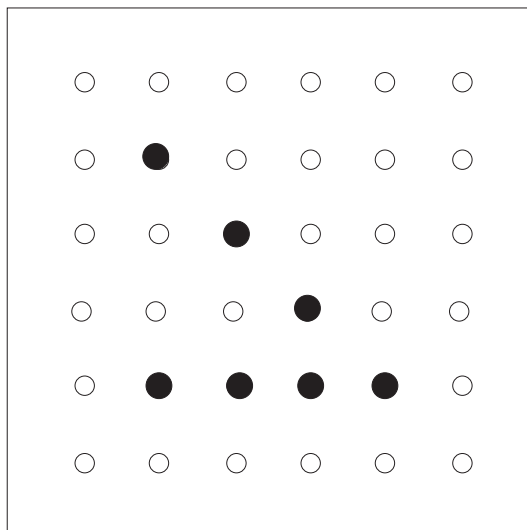

Meáin



Séimí



Sorcha



Seán

Faigheann Séimí airgead póca €2.50. Faigheann Sorcha €3.00 agus faigheann Seán €3.50.

$€2.50 + €3.00 + €3.50 = €9.00$. Sin méid iomlán an airgid phóca. Dá mba mhaith le Mamaí an méid céanna a thabhairt do gach aon duine díobh, roinnfeadh sí €9.00 ar 3 agus thabharfadh sí €3.00 an duine dóibh. ($€9.00 \div 3 = €3$).

Airgead póca €3 ar meán a fuair na páistí.

Chuaigh triúr páistí ag siopadóireacht don Nollaig. Chaith Seán €8. Chaith Muireann €19 agus chaith Éimear €20. Chaith gach duine díobh €19 ar meán.

Bíonn an meán áit éigin idir an luach is airde agus an luach is ísle. Is é sin le rá, bíonn sé áit éigin sa lár.

Sampla: Faigh meán na n-uimhreacha seo a leanas: 4, 5 agus 6

$$(4 + 5 + 6) \div 3 = 15 \div 3 = 5$$

Is mar seo a fhaigheann tú an meán:

Suimigh na luachanna go léir le chéile.

Roinn an t-iomlán ar líon na luachanna.

Faigh meán na luachanna seo a leanas:

①

(a) {2, 3, 10}

(b) {4, 4, 7}

(c) {3, 8, 10}

(d) {2, 8, 12, 14}

(e) {41, 44, 50, 51, 52, 62}

②

Faigh meán na luachanna seo a leanas:

(a) {3·4, 3·5, 2·1}

(b) {€8, €12, €7, €11}

(c) $\{1\frac{1}{2}, 3\frac{3}{4}, \frac{3}{4}\}$

(d) {€5.50, €2.50, €1}

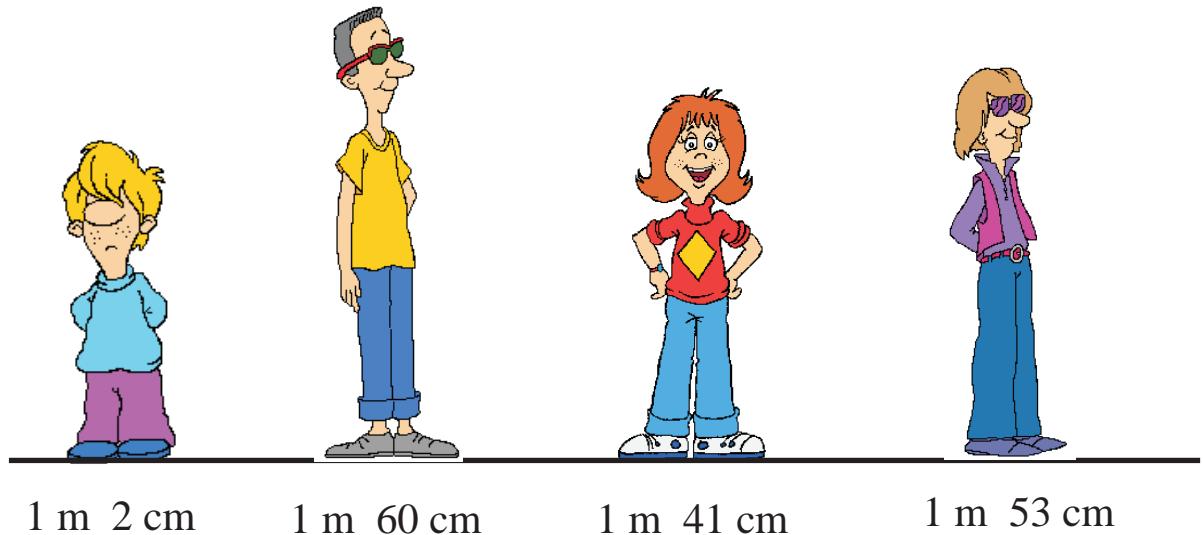

① Cad é meánairde na bpáistí seo?

② Cé mhéad leabhar ar meán a léigh gach páiste den chúigear?

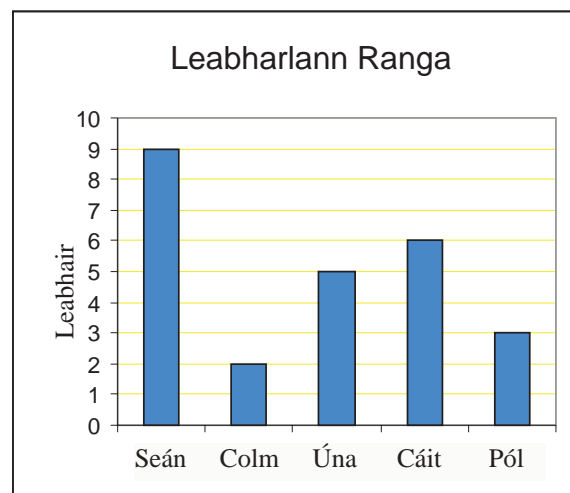

③ Seisear páistí agus iad 5 bliana, 8 mbliana, 7 mbliana, 6 bliana, 4 bliana agus 3 bliana d'aois.

Cad é aois na bpáistí sa ghrúpa ar meán?

④ Seo a leanas líon na gcúl a scóráil ár bhfoireann le cúig chluiche anuas: 4, 4, 4, 9 agus 4.

Cé mhéad cúl ar meán a scórálar in aghaidh an chluiche?



Cad é meáchan na n-úll sa ghrúpa seo ar meán.

② Léiríonn an tábla thíos an tinreamh i mo rang an tseachtain seo caite.

	Dé Luain	Dé Máirt	Dé Céadaoin	Déardaoin	Dé hAoine
Tinreamh	28	33	33	30	26

Cén tinreamh laethúil a bhí ann ar meán ?

③ 26.25 kg meáchan 4 mhála prátaí ar meán. Cad é meáchan iomlán na gceithre mhála?

④ Dhíol ceantálaí 4 theach. Díoladh dhá theach acu ar €155,000 an ceann agus dhá theach ar €71,000 an ceann. Cén praghas a bhí ar na ceithre theach ar meán?

⑤ Dhíol siopa 73 lítear bainne in aghaidh an lae Dé Luain, Dé Máirt, Dé Céadaoin agus Déardaoin ar meán. Dhíol siad 96 lítear Dé hAoine. Dhíol siad 110 lítear Dé Sathairn agus 20 lítear Dé Domhnaigh. Cén méid bainne a díoladh ar meán in aghaidh an lae?

⑥ Cad é tiús na leabhar ar an tseilf leabhar seo ar meán?

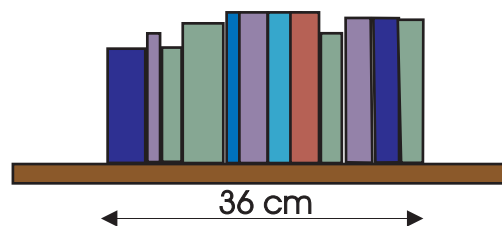

Codáin Dheachúlacha (1)

Gearradh an císte seo ina dheich bpáirt chothroma.

$\frac{1}{10}$ atá i ngach slisne.

Ainm eile ar $\frac{1}{10}$ is ea 0.1

“A náid pointe a haon” a deirimid.

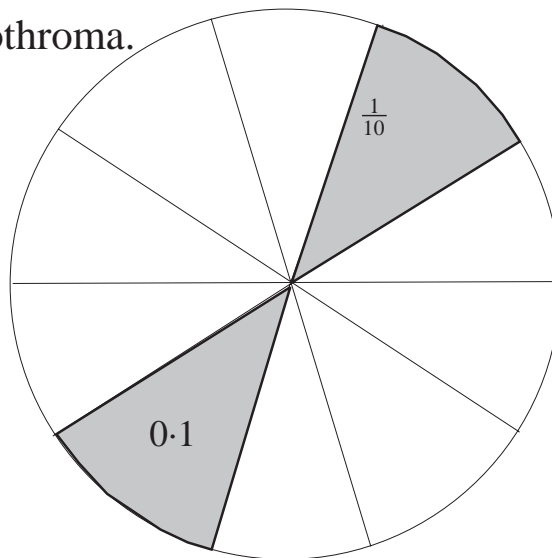

Dhá shlisne = 0.2

6 shlisne =

8 shlisne =

Aonad iomlán = 1.0

Má roinnimid aonad iomlán amháin ina 10 bpáirt chothroma beidh gach páirt = 0.1.



Is ionann an pháirt scáthaithe agus 0.4 den iomlán.

$1 + \frac{4}{10} = 1\frac{4}{10} = 1.4$. “A haon pointe a ceathair” a deirimid.

Is é is ciall le 1.4, aonad iomlán amháin **agus** 0.4 d’aonad iomlán.

Sampla eile:

Is é is brí le 2.5, dhá aonad iomlána **agus** 0.5 d’aonad iomlán, nó dhá aonad go leith.

①

Scríobh iad seo ina gcodáin dheachúlacha.

A. $1\frac{3}{10} = 1.3$

B. $1\frac{4}{10} = \square$

C. $2\frac{2}{10} = \square$

D. $3\frac{3}{10} = \square$

E. $1\frac{5}{10} = \square$

Scríobh iad seo ina gcodáin dheachúlacha.

F. $2\frac{7}{10} = \square$

G. $1\frac{9}{10} = \square$

H. $4\frac{3}{10} = \square$

I. $7\frac{7}{10} = \square$

J. $5\frac{9}{10} = \square$

Aonad iomlán amháin

= 3.3

②

= \square

③

= \square

① Líon isteach na cealla folmha thíos.

	10 cent	20 cent	30 cent	40 cent	50 cent	60 cent	70 cent	80 cent	90 cent
Codán de €1	$\frac{1}{10}$	$\frac{2}{10}$							
Codán deachúlach de €1	0.1	0.2	0.3						

Scarann an pointe an uimhir iomlán ón gcodán deachúlach.

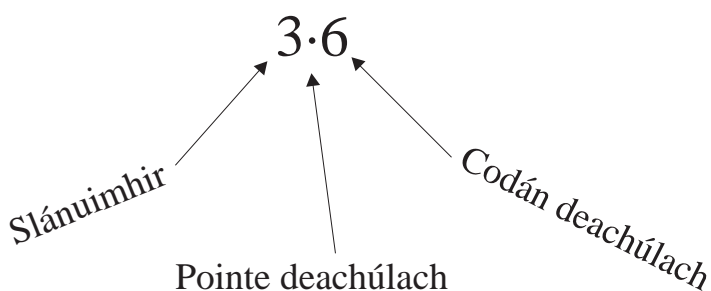

② Scríobh na codáin seo ina gcodáin dheachúlacha.

A. $\frac{3}{10} =$

B. $\frac{1}{10} =$

C. $\frac{9}{10} =$

D. $\frac{8}{10} =$

E. $\frac{7}{10} =$

F. $\frac{2}{10} =$

G. $\frac{4}{10} =$

H. $\frac{5}{10} =$

I. $\frac{6}{10} =$

J. $\frac{1}{10}$ de €1 = cent

K. 0.5 de €1 = cent

L. 0.4 de €1 = cent

M. $\frac{7}{10}$ de €1 = cent

N. 0.5 de €2 = cent

O. 0.4 de €4 = cent

P. 0.5 de 80 cent = cent

①

Is féidir codáin dheachúlacha a thaispeáint ar chláir nodaireachta.

Líon isteach na poncanna atá ar iarraidh thíos.

C	D	A	$\frac{1}{10}$
*	*	*	*
*	*		*

C	D	A	$\frac{1}{10}$

C	D	A	$\frac{1}{10}$

2 2 1 • 2

6 4 4 • 6

9 4 7 • 9

②

Scríobh na huimhreacha i ngach sraith in ord méide.

Tosaigh leis an uimhir is lú.

A.	1.6,	0.9,	1.2,	2.1,	<input type="text"/>	<input type="text"/>	<input type="text"/>	<input type="text"/>
B.	0.5,	2.1,	5.0,	4.8	<input type="text"/>	<input type="text"/>	<input type="text"/>	<input type="text"/>
C.	$1\frac{6}{10}$,	1.2,	1.7,	1.5	<input type="text"/>	<input type="text"/>	<input type="text"/>	<input type="text"/>
D.	9.3,	4.9,	7.6,	8.0	<input type="text"/>	<input type="text"/>	<input type="text"/>	<input type="text"/>
E.	6.2,	4.9,	1.8,	3.5	<input type="text"/>	<input type="text"/>	<input type="text"/>	<input type="text"/>
F.	1.7,	0.8,	1.9,	$1\frac{6}{10}$	<input type="text"/>	<input type="text"/>	<input type="text"/>	<input type="text"/>

Faigh 10 mbealach le dhá chodán dheachúlacha a shuimiú le chéile chun 1 a dhéanamh.

Ná pioc na bealaí is éasca!

①

$$(a) \quad \boxed{0.85} + \boxed{0.15} = 1$$

$$(b) \quad \boxed{} + \boxed{} = 1$$

$$(c) \quad \boxed{} + \boxed{} = 1$$

$$(d) \quad \boxed{} + \boxed{} = 1$$

$$(e) \quad \boxed{} + \boxed{} = 1$$

$$(f) \quad \boxed{} + \boxed{} = 1$$

$$(g) \quad \boxed{} + \boxed{} = 1$$

$$(h) \quad \boxed{} + \boxed{} = 1$$

$$(i) \quad \boxed{} + \boxed{} = 1$$

$$(j) \quad \boxed{} + \boxed{} = 1$$

Faigh 5 bhealach le trí chodán dheachúlacha a shuimiú le chéile chun 1 a dhéanamh.

②

$$(a) \quad \boxed{0.65} + \boxed{0.15} + \boxed{0.2} = 1$$

$$(b) \quad \boxed{} + \boxed{} + \boxed{} = 1$$

$$(c) \quad \boxed{} + \boxed{} + \boxed{} = 1$$

$$(d) \quad \boxed{} + \boxed{} + \boxed{} = 1$$

①

Cén luach atá ag gach figiúr a bhfuil líne faoi.

A. $39.\underline{6} = 3$ dheich

D. $\underline{3}45.5 =$

B. $139.\underline{8} =$

E. $14\underline{2}.3 =$

C. $1\underline{6}.2 =$

F. $6\underline{2}7.1 =$

Líon isteach an tsóinseáil cheart sna cealla folmha thíos.

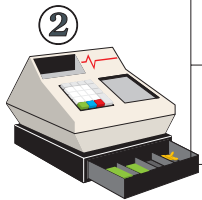

②

Airgead	€1.00	€1.00	€0.80	€0.80	€0.50	€0.50	90 cent
Chaith mé	€0.30	€ 0.40	€0.40	€0.80	€0.40	€0.49	€0.80
An tSóinseáil	€0.70						

③

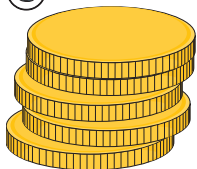

Airgead	€0.75	€0.40	€0.66	€0.90	€0.50	€0.55	80 cent
Chaith mé	€0.72	€0.33	€0.40	€0.81	€0.44	€0.40	€0.08
An tSóinseáil	€0.03						

④

<p>A. €2.00 – 85 cent = <input type="text"/></p> <p>B. €2.00 – €1.85 = <input type="text"/></p> <p>C. €3.00 – €0.85 = <input type="text"/></p> <p>D. €4.00 – €2.20 = <input type="text"/></p> <p>E. €5.00 – €3.50 = <input type="text"/></p>	<p>F. €2.00 – 100 cent = <input type="text"/></p> <p>G. €3.00 – 110 cent = <input type="text"/></p> <p>H. €4.00 – €3.25 = <input type="text"/></p> <p>I. €5.00 – 65 cent = <input type="text"/></p> <p>J. €2.50 – 60 cent = <input type="text"/></p>
--	--

Líon isteach an freagra i ngach bosca thíos.

A.	€0.34 =	<input type="text"/>	cent
B.	€0.98 =	<input type="text"/>	cent
C.	€0.62 =	<input type="text"/>	cent
D.	€0.73 =	<input type="text"/>	cent
E.	€0.25 =	<input type="text"/>	cent
F.	€0.84 =	<input type="text"/>	cent
G.	€0.16 =	<input type="text"/>	cent
H.	€0.38 =	<input type="text"/>	cent
I.	€0.45 =	<input type="text"/>	cent
J.	€0.59 =	<input type="text"/>	cent

Úsáid comhartha an €don mhéid iomlán atá le cur i ngach bosca taisce.

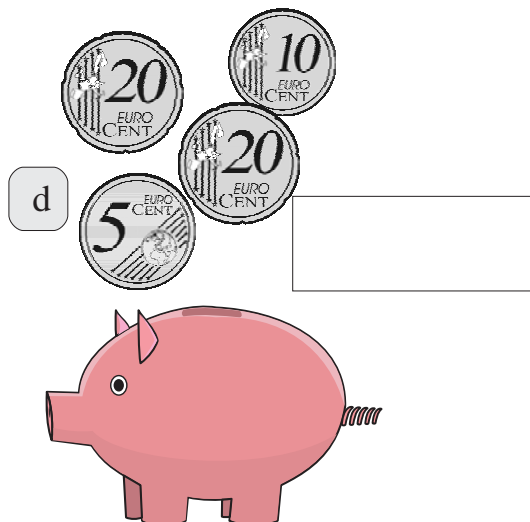
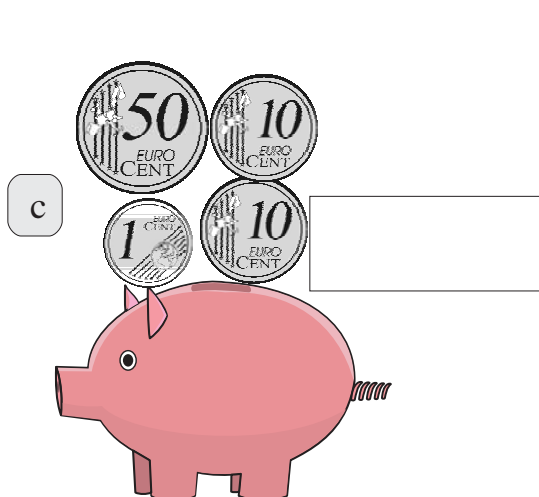
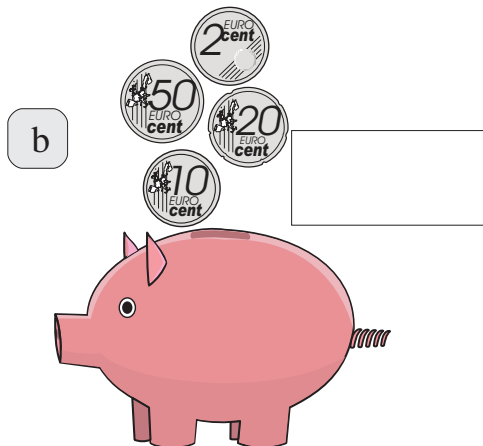

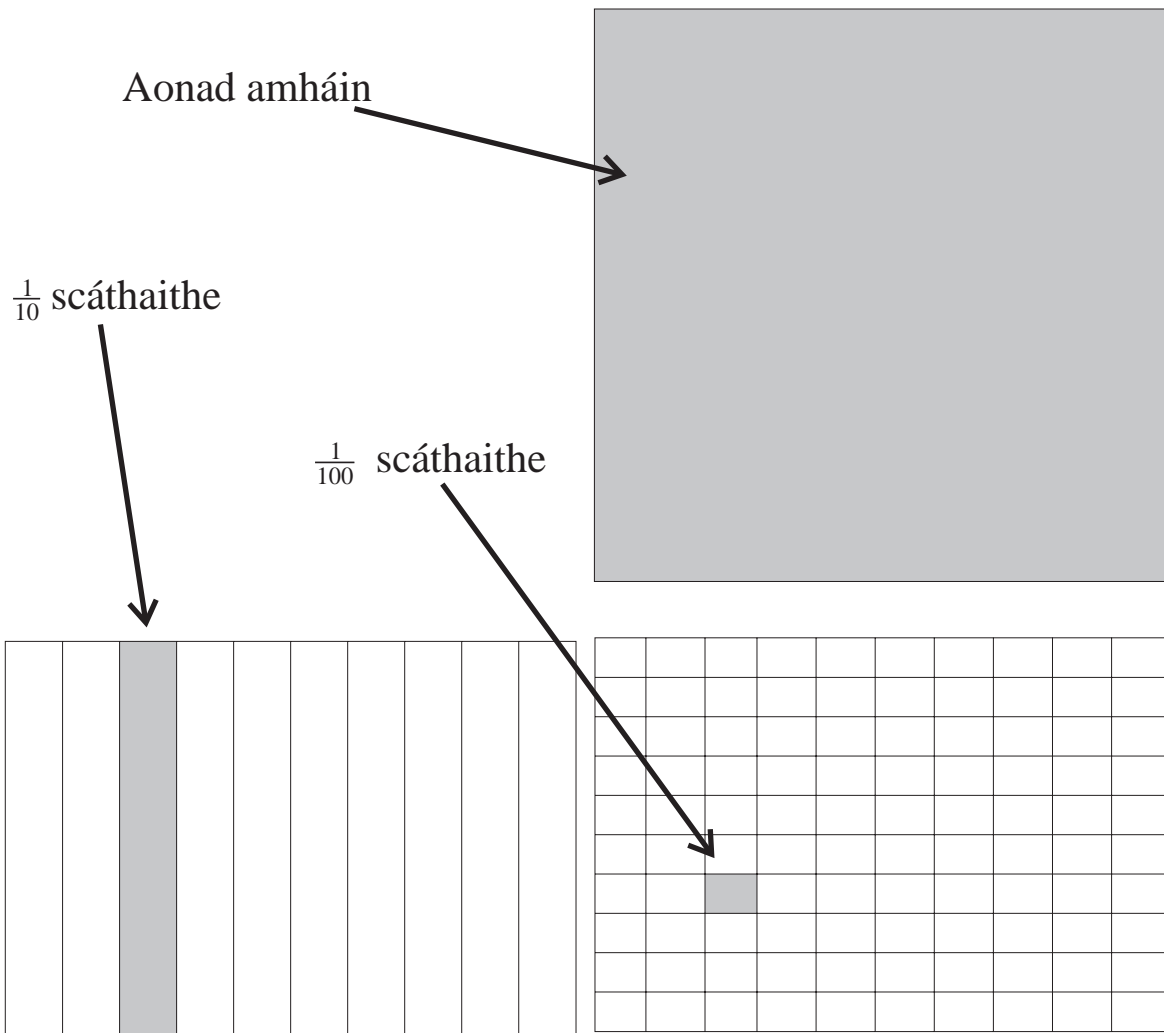

Aonad amháin	$\frac{1}{10}$	$\frac{1}{100}$
€1	10 cent	1 cent
€1.00	€0.10	€0.01
1.0	0.1	0.01

Cén méid airgid atá agat? Úsáid comhartha an €

①

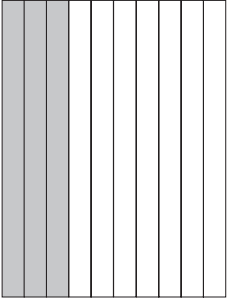
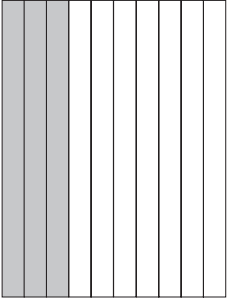
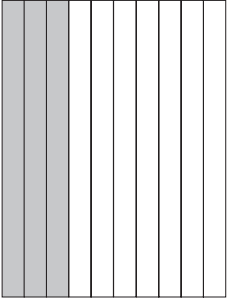
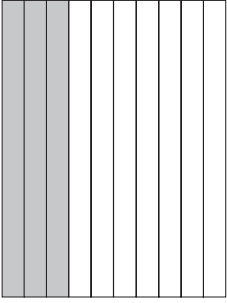
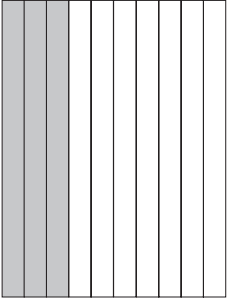
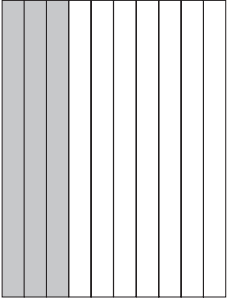
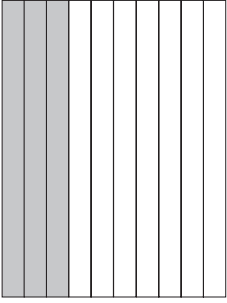
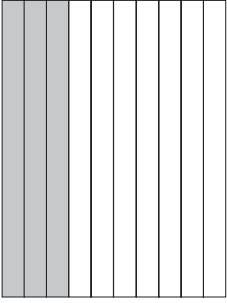
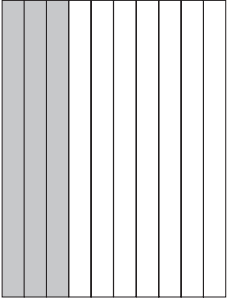
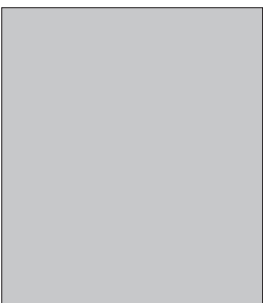

②

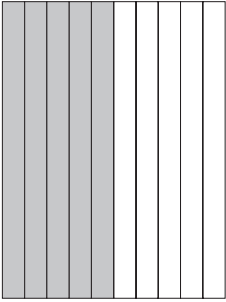
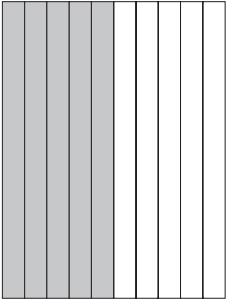
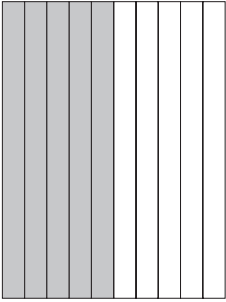
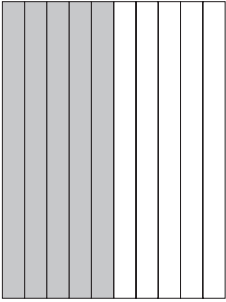
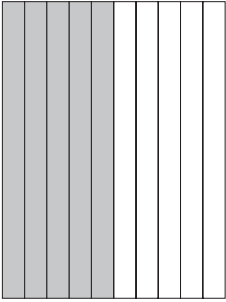
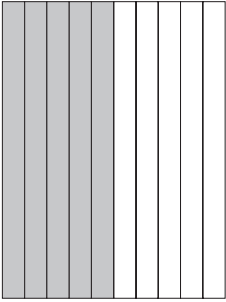
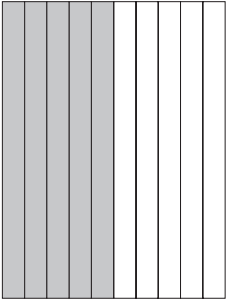
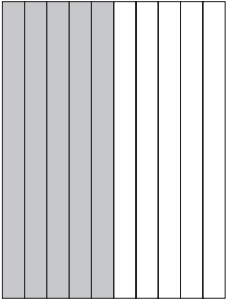
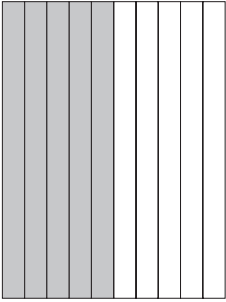
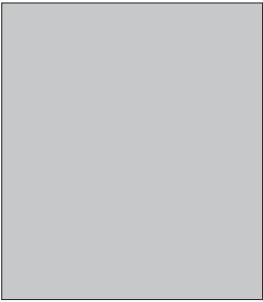

③

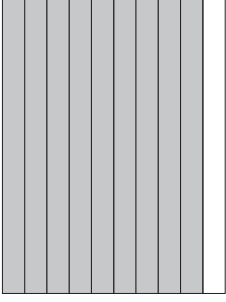
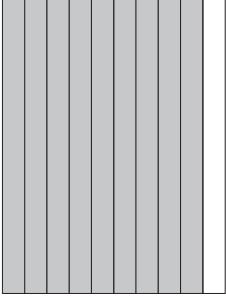
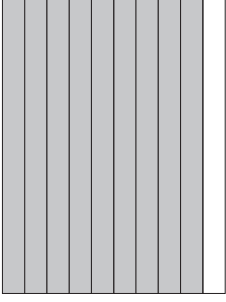
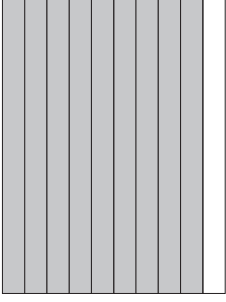
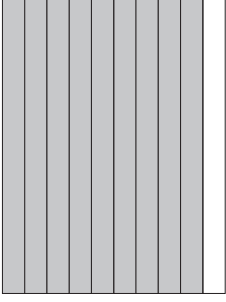
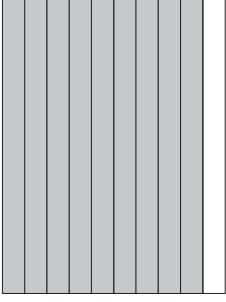
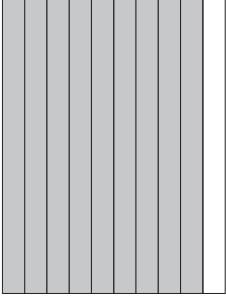
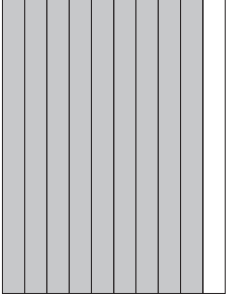
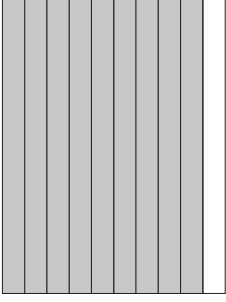
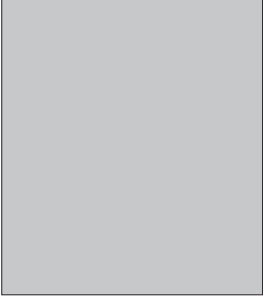

④

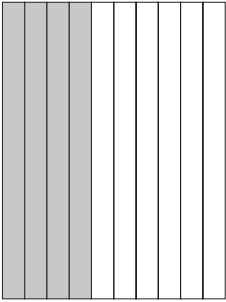
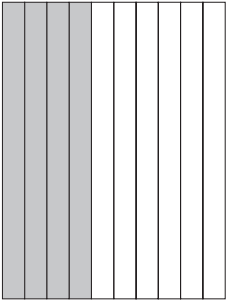
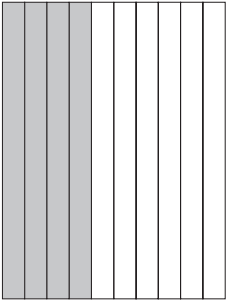
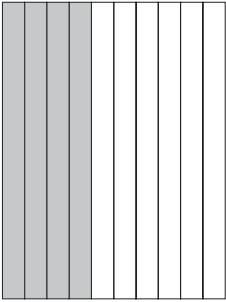
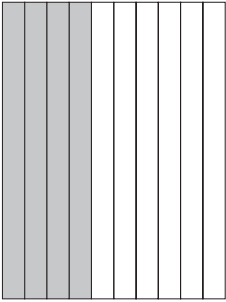
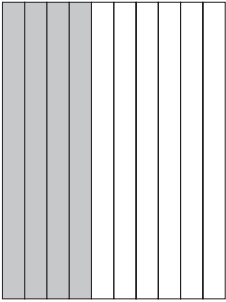
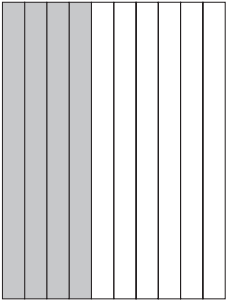
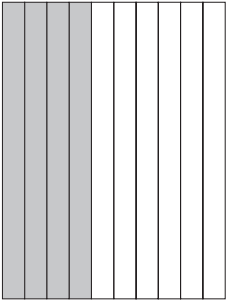
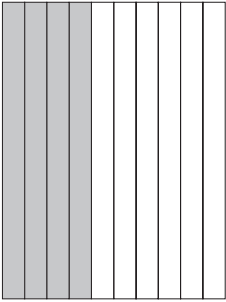
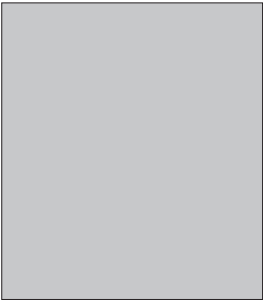

Cén méid airgid atá agat? Úsáid comhartha an €

①

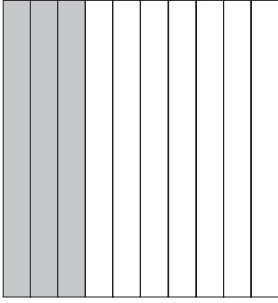
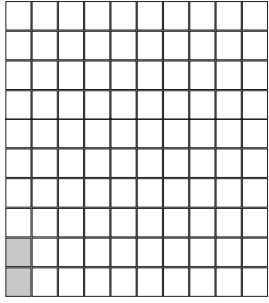
②

③

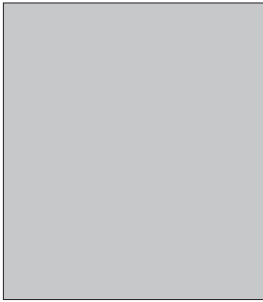
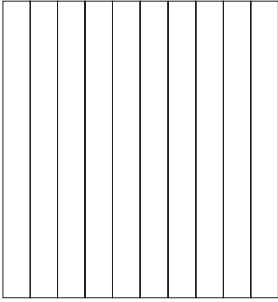
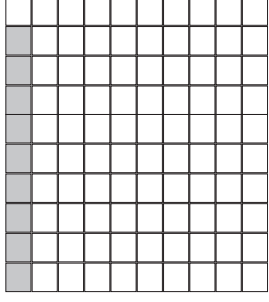
④

①

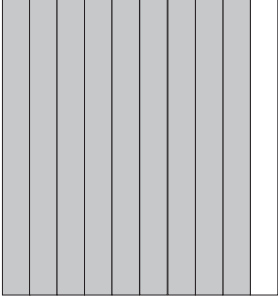
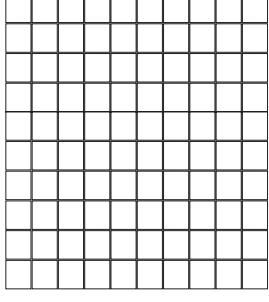

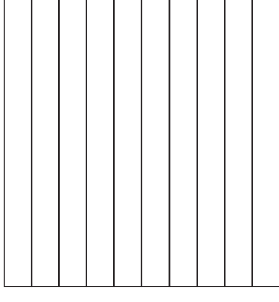
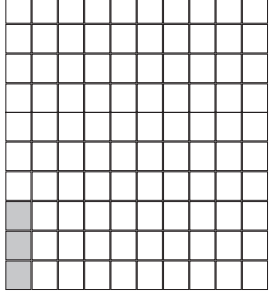
+

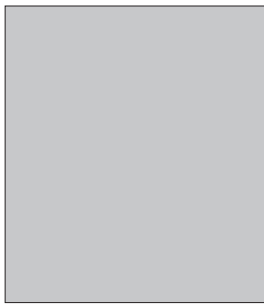

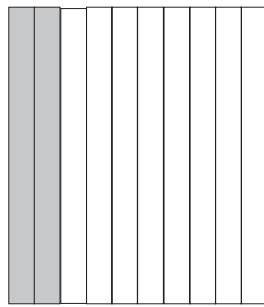
+

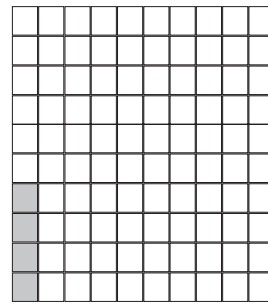

=

1.24

1 aonad amháin = 1.0

$\frac{2}{10} = 0.2$

$\frac{4}{100} = 0.04$

$$1.0 + 0.2 + 0.04 = 1.24$$

②

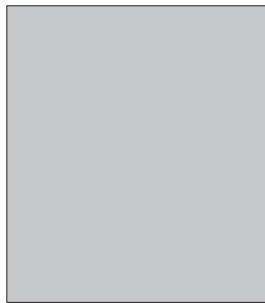

+

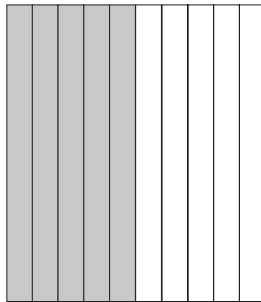

+

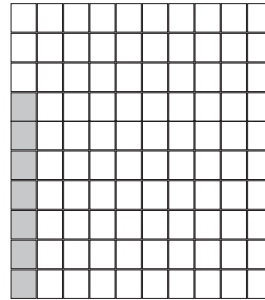

=

③

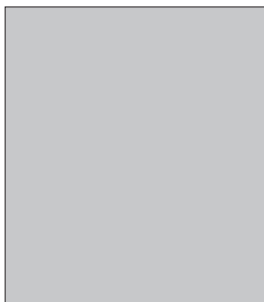

+

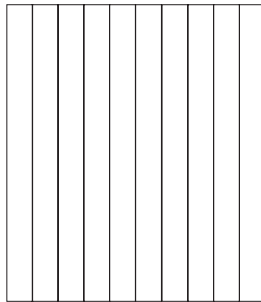

+

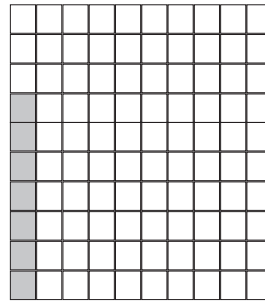

=

④

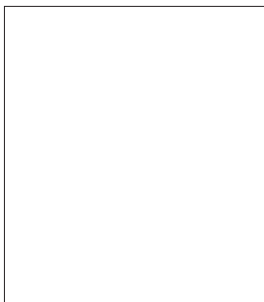

+

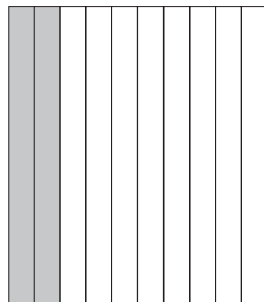

+

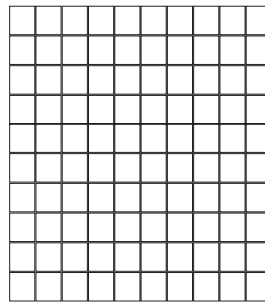

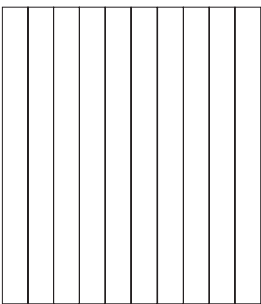
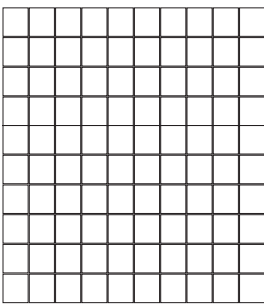

=

Scáthaigh na páirteanna cuí leis na huimhreacha deachúlacha seo a léiriú.

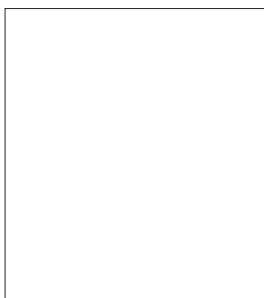
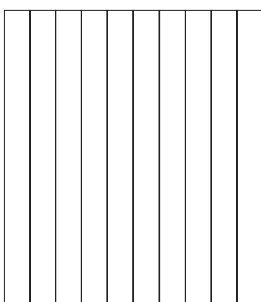
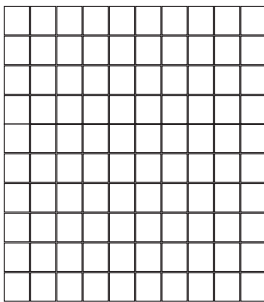
①  +  +  =

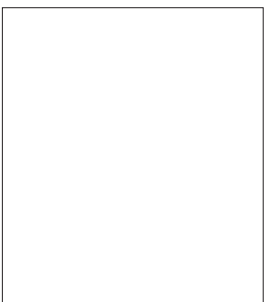
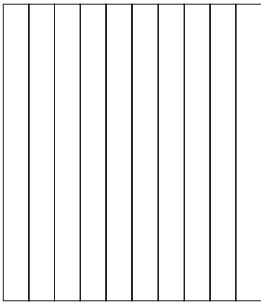
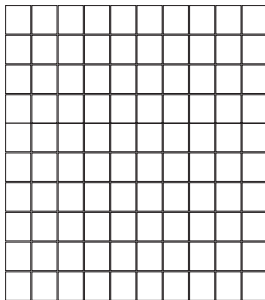
②  +  +  =

③  +  +  =

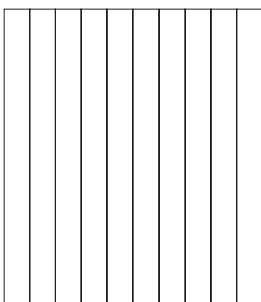
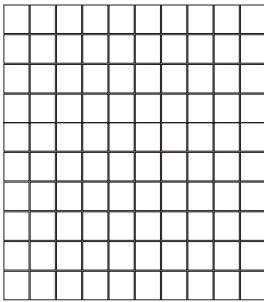
④  +  +  =

An bhfeiceann tú gurb ionann scáthú a dhéanamh ar 10 gcearnóg $\frac{1}{100}$ agus scáthú a dhéanamh ar aon cholún $\frac{1}{10}$ amháin?



Cuimhnigh: 3 cent = €0.03

Athscríobh na codáin seo a leanas ina gcodáin dheachúlacha anois. Cuimhnigh ar a bhfuil foghlamtha agat faoin airgead.

Ná húsáid siombail airgid.

①

A. $\frac{8}{100} =$

B. $\frac{4}{100} =$

C. $\frac{39}{100} =$

D. $\frac{21}{100} =$

E. $\frac{6}{100} =$

F. $\frac{65}{100} =$

G. $\frac{59}{100} =$

H. $\frac{19}{100} =$

I. $\frac{49}{100} =$

J. $\frac{84}{100} =$

Scríobh na codáin seo ina n-uimhreacha deachúlacha.

②

A. $2 + \frac{4}{10} + \frac{6}{100} =$

B. $9 + \frac{1}{10} + \frac{3}{100} =$

C. $3 + \frac{3}{10} + \frac{1}{100} =$

D. $6 + \frac{1}{10} + \frac{2}{100} =$

E. $4 + \frac{2}{10} + \frac{3}{100} =$

F. $7 + \frac{3}{10} + \frac{8}{100} =$

G. $8 + \frac{5}{10} + \frac{6}{100} =$

H. $41 + \frac{4}{10} + \frac{9}{100} =$

I. $62 + \frac{2}{10} + \frac{2}{100} =$

J. $97 + \frac{9}{10} + \frac{7}{100} =$

K. $84 + \frac{8}{10} + \frac{1}{100} =$

L. $45 + \frac{9}{10} + \frac{4}{100} =$

M. $63 + \frac{7}{10} + \frac{5}{100} =$

N. $11 + \frac{1}{10} + \frac{1}{100} =$



Lá Spóirt na Scoile	
Toradh an Rás 200 Méadar	
Ainm	Am
Sorcha	29.86 soicind
Diarmaid	30.41 soicind
Colm	29.68 soicind
Deirdre	29.57 soicind
Dara	30.29 soicind

① Líon isteach ainmneacha na ndaoine a bhí sa 1ú, 2ú agus 3ú háit sa tábla ar dheis.

Ainm	Am	Áit
		1ú
		2ú
		3ú

② Cé aige a bhfuil an t-am is gaire do 30 soicind?

Lá Spóirt na Scoile	
Toradh an Rás 400 méadar	
Ainm	Am
Muireann	62.84 soicind
Tadhg	61.36 soicind
Síofra	63.41 soicind
Úna	61.00 soicind
Diarmaid	61.49 soicind

③ Líon isteach ainmneacha na ndaoine a bhí sa 1ú, 2ú agus 3ú háit sa rás 400 méadar sa tábla ar dheis.

Ainm	Am	Áit
		1ú
		2ú
		3ú

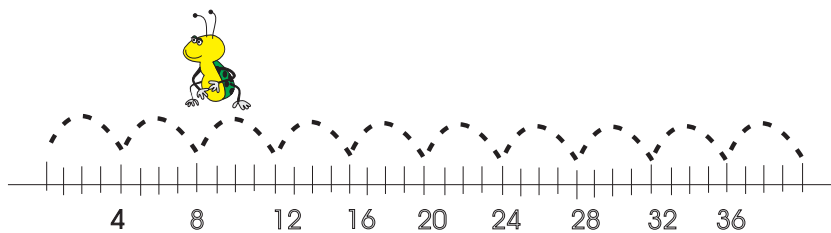

Líon isteach na chéad trí uimhir eile i ngach seicheamh thíos.

①

- A. 2.37, 2.39, _____
- B. 6.54, 6.56, _____
- C. 1.22, 1.24, _____
- D. 5.31, 5.33, _____
- E. 13.64, 13.66, _____
- F. 12.82, 12.86, _____
- G. 3.56, 3.59, _____
- H. 4.08, 4.09, _____
- I. 13.07, 13.17, _____
- J. 6.34, 6.37, _____

Is é is **uimhir phríomha** ann:



Uimhir nach féidir í a roinnt, gan fuílleach, ach amháin uirthi féin agus ar a haon e.g. 5, 7, 13.

Ní uimhir phríomha í 1.

Cé acu is mó?

Cuir ciorcal timpeall ar an méid is mó as gach péire.

- ① $\frac{1}{2}$ de 66 nó $\frac{2}{3}$ de 51
- ② $\frac{1}{4}$ de 96 nó $\frac{1}{3}$ de 75
- ③ $\frac{2}{5}$ de 40 nó 0.5 de 30
- ④ 0.75 de 60 nó 0.9 de 55
- ⑤ 0.25 de 84 nó $\frac{4}{5}$ de 25

- ⑥ Suimigh le chéile do rogha freagraí thuas chun suim iomlán a dhéanamh atá chomh gar do 100 agus is féidir.

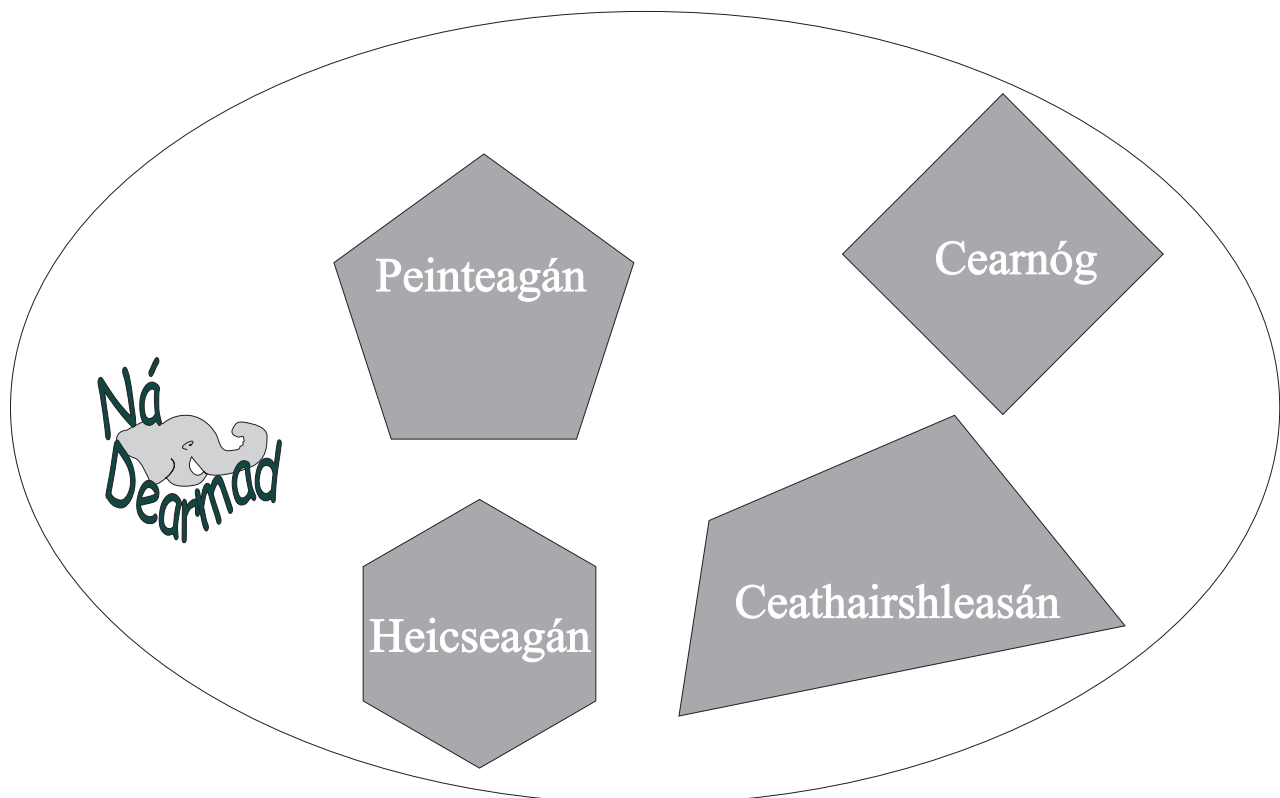

Bíodh na pointí deachúlacha go díreach faoina chéile agus tú ag suimiú nó ag dealú uimhreacha deachúlacha. Suimiú atá i gceist i gcás 1 go dtí 10 thíos, agus dealú i gcás 11 go dtí 25.

Suimigh

①

$$\begin{array}{r} 1.15 \\ + 2.32 \\ \hline \end{array}$$

②

$$\begin{array}{r} 2.06 \\ + 1.82 \\ \hline \end{array}$$

③

$$\begin{array}{r} 3.42 \\ + 1.74 \\ \hline \end{array}$$

④

$$\begin{array}{r} 5.16 \\ + 2.07 \\ \hline \end{array}$$

⑤

$$\begin{array}{r} 4.15 \\ + 2.38 \\ \hline \end{array}$$

Suimigh

⑥

$$\begin{array}{r} 2.03 \\ + 1.47 \\ + 2.98 \\ \hline \end{array}$$

⑦

$$\begin{array}{r} 3.48 \\ + 2.94 \\ + 3.60 \\ \hline \end{array}$$

⑧

$$\begin{array}{r} 1.58 \\ + 7.23 \\ + 1.99 \\ \hline \end{array}$$

⑨

$$\begin{array}{r} 1.07 \\ + 9.45 \\ + 2.98 \\ \hline \end{array}$$

⑩

$$\begin{array}{r} 1.06 \\ + 8.76 \\ + 2.38 \\ \hline \end{array}$$

Deaigh

⑪

$$\begin{array}{r} 9.93 \\ - 1.72 \\ \hline \end{array}$$

⑫

$$\begin{array}{r} 6.74 \\ - 0.32 \\ \hline \end{array}$$

⑬

$$\begin{array}{r} 6.83 \\ - 1.60 \\ \hline \end{array}$$

⑭

$$\begin{array}{r} 9.75 \\ - 6.71 \\ \hline \end{array}$$

⑮

$$\begin{array}{r} 7.82 \\ - 1.36 \\ \hline \end{array}$$

Deaigh

⑯

$$\begin{array}{r} 9.72 \\ - 3.43 \\ \hline \end{array}$$

⑰

$$\begin{array}{r} 9.66 \\ - 3.18 \\ \hline \end{array}$$

⑱

$$\begin{array}{r} 8.21 \\ - 1.49 \\ \hline \end{array}$$

⑲

$$\begin{array}{r} 7.34 \\ - 2.76 \\ \hline \end{array}$$

⑳

$$\begin{array}{r} 5.13 \\ - 3.23 \\ \hline \end{array}$$

Deaigh

㉑

$$\begin{array}{r} 8.99 \\ - 7.99 \\ \hline \end{array}$$

㉒

$$\begin{array}{r} 6.84 \\ - 5.91 \\ \hline \end{array}$$

㉓

$$\begin{array}{r} 5.83 \\ - 2.84 \\ \hline \end{array}$$

㉔

$$\begin{array}{r} 8.40 \\ - 4.80 \\ \hline \end{array}$$

㉕

$$\begin{array}{r} 11.99 \\ - 10.77 \\ \hline \end{array}$$

An Lá Spóirt

Líon isteach ainm an té a bhí sa 1ú, 2ú, 3ú, 4ú agus 5ú háit i ngach comórtas.

①



An Léim Fhada: An Toradh	
Ainm	Fad
Sorcha	3.86 m
Diarmaid	4.41 m
Colm	3.23 m
Deirdre	3.99 m
Dara	4.12 m

An Léim Fhada	
Ainm	Áit
	1ú
	2ú
	3ú
	4ú
	5ú

②



An Léim Chuaille: An Toradh	
Ainm	Airde
Sorcha	4.86 m
Diarmaid	3.41 m
Colm	4.45 m
Deirdre	3.67 m
Dara	4.30 m

An Léim Chuaille	
Ainm	Áit
	1ú
	2ú
	3ú
	4ú
	5ú

③

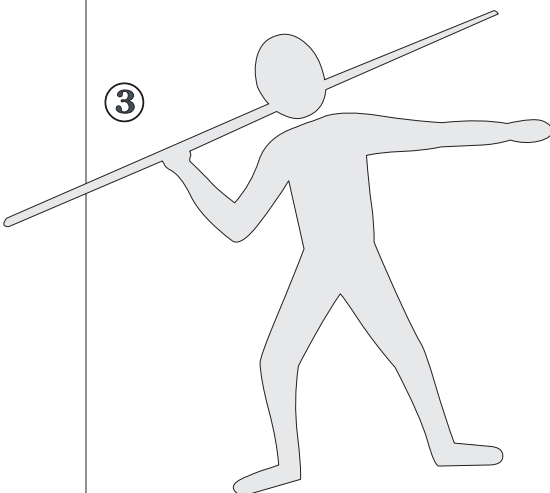

An Ga: An Toradh	
Ainm	Fad
Sorcha	38.86 m
Diarmaid	31.41 m
Colm	48.45 m
Deirdre	33.67 m
Dara	44.30 m

An Léim Fhada:	
Ainm	Áit
	1ú
	2ú
	3ú
	4ú
	5ú

Breathnaigh Leathanach 8 - 8 arís má tá deacracht ar bith agat leis na huimhirchearnóga seo.

$0.01 \times 10 = 0.1$

Is ionann cearnóg bheag amháin méadaithe faoi 10 agus 10 gcearnóg bheaga.

$0.04 \times 10 = 0.4$

$0.06 \times 10 = 0.6$

① Ar thug tú aon rud faoi deara maidir leis na freagraí? Déan iad seo anois.

$0.02 \times 10 =$

$0.07 \times 10 =$

$0.05 \times 10 =$

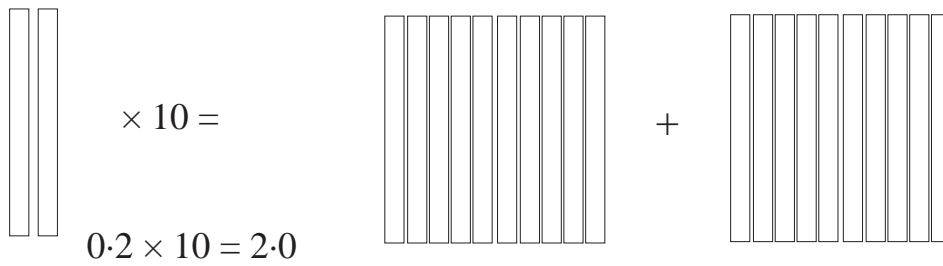
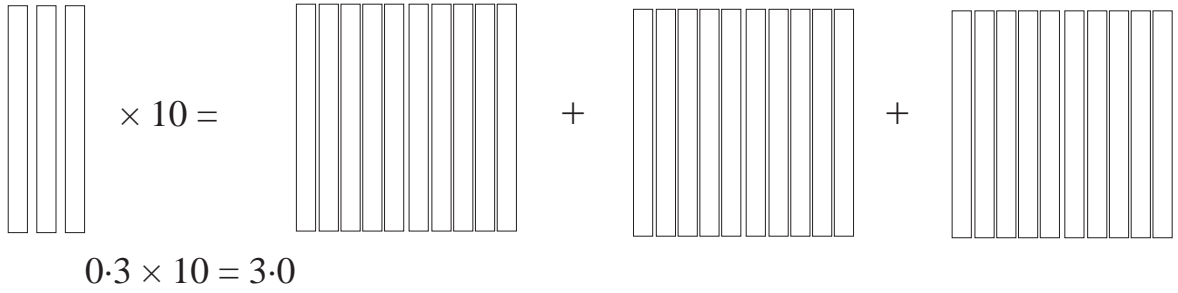

Déan iad seo anois.

A. $0.4 \times 10 =$

B. $0.6 \times 10 =$

C. $0.5 \times 10 =$

D. $0.8 \times 10 =$

E. $0.9 \times 10 =$

F. $0.7 \times 10 =$



Uimhir Ilchodach, sin uimhir a bhfuil fachtóirí aici.

e.g. 16, 20, 36.

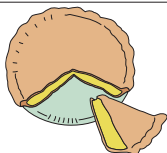

Inbhéartú ar iolrú is ea roinnt. Sa tslí chontrártha a oibríonn sí.

①

A. $0.2 \div 10 =$

F. $0.7 \div 10 =$

B. $0.6 \div 10 =$

G. $0.1 \div 10 =$

C. $0.4 \div 10 =$

H. $0.9 \div 10 =$

D. $0.5 \div 10 =$

I. $0.8 \div 10 =$

E. $0.3 \div 10 =$

②

A. $0.37 \times 10 =$

F. $0.21 \times 10 =$

B. $0.62 \times 10 =$

G. $2.46 \times 10 =$

C. $0.74 \times 10 =$

H. $0.33 \times 10 =$

D. $3.56 \times 10 =$

I. $1.76 \times 10 =$

E. $4.63 \times 10 =$

J. $9.14 \times 10 =$

③

A. $0.3 \div 10 =$

F. $0.07 \div 10 =$

B. $1.7 \div 10 =$

G. $3 \div 10 =$

C. $0.47 \div 10 =$

H. $0.06 \div 10 =$

D. $6.26 \div 10 =$

I. $2.06 \div 10 =$

E. $3.08 \div 10 =$

J. $1 \div 10 =$

①

4·2 +	3·8 +	5·3 +	5 ×
1·4 +	1·7 +	2·9 +	3·5 +
5·6 +	4·1 +	3·2 +	4·8 +
9 ×	2 ×	3·4 +	3·9 +

Chun an uimhir i ngach cill thuas a dhéanamh, roghnaigh dhá cheann de na huimhreacha thíos agus úsáid an comhartha atá sa chill.

Nótáil: Tá na comharthaí sna cealla **an-tábhachtach**.

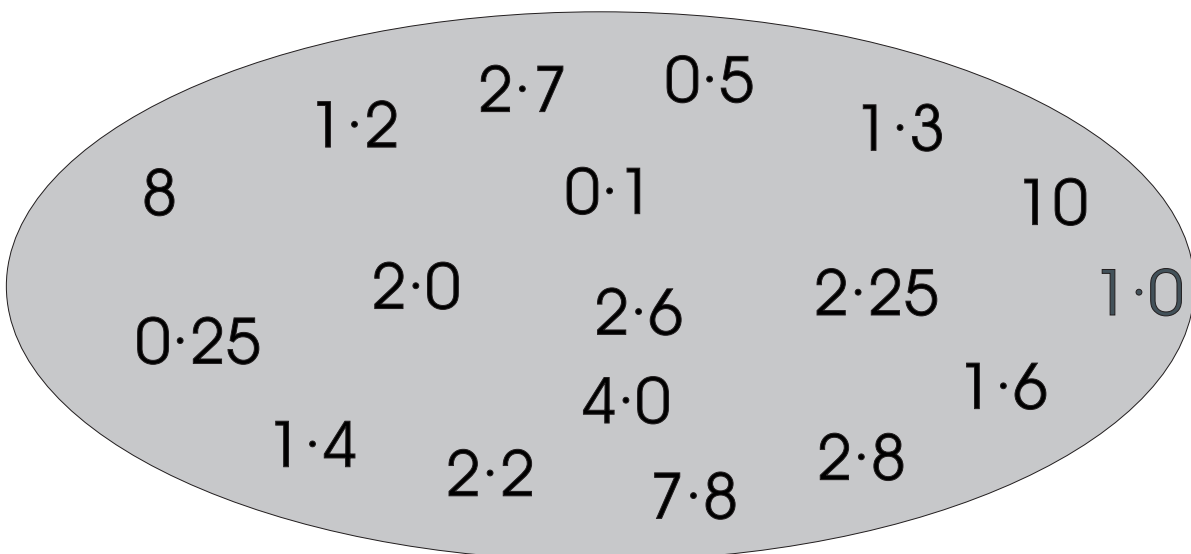

$$3.71 \times 10 = 37.1$$

$$3.71 \times 100 = 371$$

$$2.43 \div 10 = 0.243$$

$$2.43 \div 100 = 0.0243$$

Ar thug tú aon rud faoi deara?

Bogann gach digit spás amháin ar chlé agus tú ag iolrú faoi 10.
Bogann gach digit spás amháin ar dheis agus tú ag roinnt ar 10.

Bogann gach digit dhá spás ar chlé agus tú ag iolrú faoi 100.
Bogann gach digit dhá spás ar dheis agus tú ag roinnt ar 100.

Déan iad seo anois.

①

(a) $1.35 \times 10 =$

(b) $0.345 \times 10 =$

(c) $2.47 \times 100 =$

(d) $6.238 \times 100 =$

(e) $4.306 \times 100 =$

②

(a) $15.6 \div 10 =$

(b) $6.6 \div 10 =$

(c) $0.7 \div 100 =$

(d) $37.2 \div 100 =$

(e) $0.2 \div 100 =$

① Scríobh ina ndeachúlacha $\frac{16}{10}$, $\frac{39}{10}$, $\frac{42}{10}$

② $0.25 = \frac{\quad}{10} + \frac{\quad}{100}$

③ Bhí €49 ag buachaill. Chaith sé 0.5 de. Cé mhéad a bhí fágtha aige?

④ Cuir ciorcal timpeall ar an gcodán deachúlach atá níos mó ná $\frac{1}{2}$.
0.2, 0.75, 0.5, 0.25

⑤ Cad é 0.1 de 200?

⑥ Cad é 0.7 de €35?

⑦ Cén codán deachúlach den chiorcal atá

(a) scáthaithe (b) bán ?

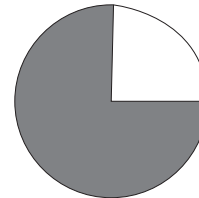

⑧ Cad é 0.75 de 3.6?

⑨ Cad é 0.5 de €50?

⑩ D'ith buachaill $\frac{3}{10}$ dá chuid milseán. 14 mhilseán a bhí fágtha aige.

Cé mhéad milseán a bhí aige ar dtús?

①

Bhí €18.00 ag buachaill. Chaith sé 0.3 dá chuid airgid.
Cén méid airgid a chaith sé?

②

Cé mhéad píosa sreinge 3.5 cm ar fad is féidir a ghearradh as píosa
atá 329 cm ar fad?

③

Roinn 2.66 kg ina bpaicéid agus 35 g i ngach paicéad.
Cé mhéad paicéad a bheidh agat?

④

Cén uimhir atá 68.34 níos lú ná 700?

⑤

Rinne rothaí 0.7 dá thuras, ach bhí 63 km fós le cur de.
Cén fad a bhí sa turas iomlán?

⑥

Cad is gá a chur le 16.06 chun 624 a dhéanamh?

Cóimheas

Tá Síle 260 cm ar airde. Tá Seán 130 cm ar airde. Níl Seán ach leath chomh hard le Síle.



CÓIMHEAS a úsáidtear agus rudaí á gcur i gcomparáid.

Tá airde Shíle agus airde Sheáin 260 cm le 130 cm nó sa chóimheas 26 le 13.

Mar seo a scríobhaimid an cóimheas sin -

$$26 : 13$$

nó

$$2 : 1$$

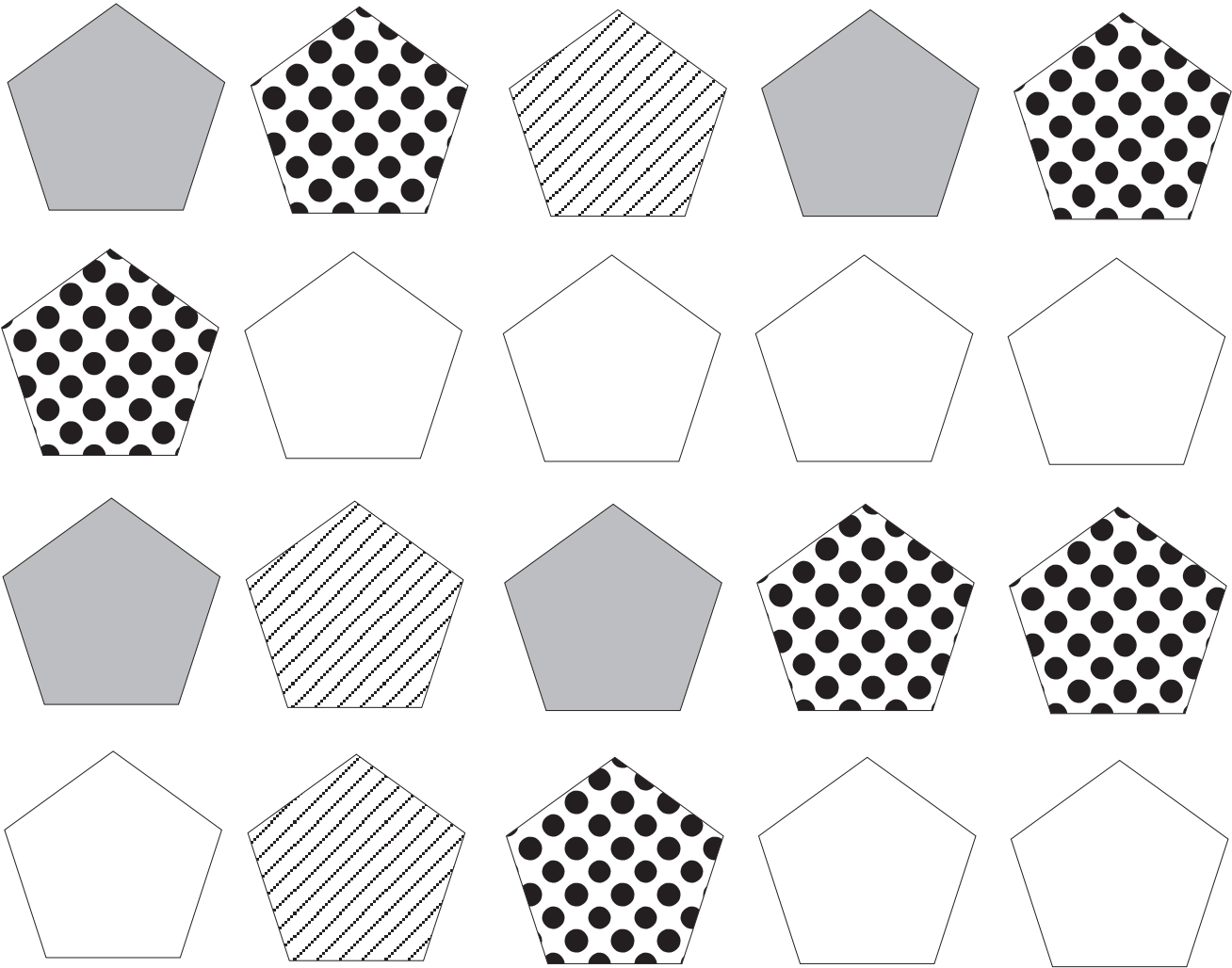

Cóimheas na bpeinteagán spotach leis na peinteagáin bhána ná 6:7.

① Líon isteach na cóimheasa sna boscaí thíos.

(a) spotach : stríocach = :

(b) liath : bán = :

(c) bán : liath = :

(d) liath : spotach = :

(e) stríocach : bán = :

(f) liath : stríocach = :

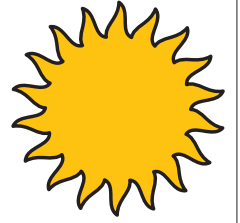

Is é 4 m fad an scátha a chaitheann an cuaille seo (ag tráth áirithe den lá).

Tá an cuaille 1 m ar airde. Is ionann airde an chuaille agus an ceathrú cuid d'fhad an scátha.

Is é a haon lena ceathair (1:4) an cóimheas idir airde an chuaille agus fad an scátha.

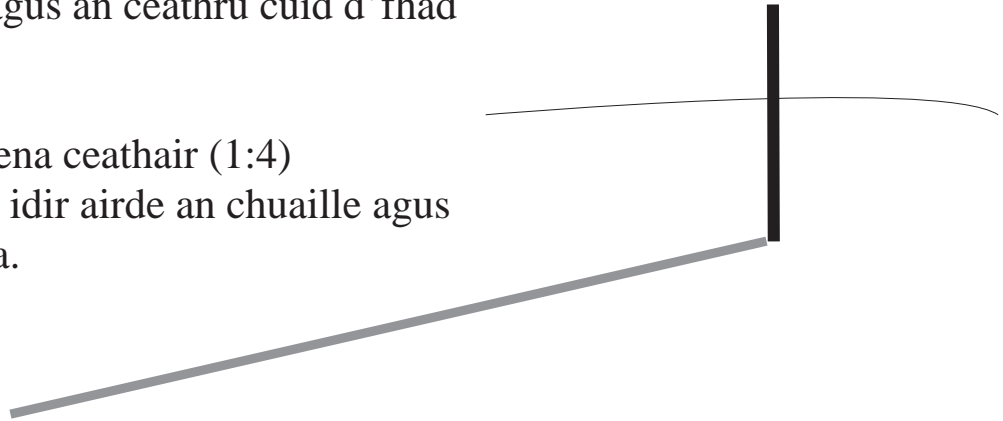

Scríobh na cóimheasa seo san fhoirm is simplí.

①

(a) $2 : 8 = \square : \square$

(b) $4 : 12 = \square : \square$

(c) $15 : 12 = \square : \square$

(d) $8 : 24 = \square : \square$

(e) $3 : 9 = \square : \square$

②

(a) $10 : 5 = \square : \square$

(b) $12 : 10 = \square : \square$

(c) $20 : 12 = \square : \square$

(d) $18 : 3 = \square : \square$

(e) $20 : 4 = \square : \square$



Rudaí den chineál céanna amháin
a chuirtear i gcomparáid.

Is féidir linn, mar shampla,
kg a chur i gcomparáid le kg,
cm le cm agus € le €

Cad é cóimheas

- ① (a) 5 cent le 20 cent? :
- (b) 25 cent le 15 cent? :
- (c) €1 le 75 cent? :
- (d) 1 uair an chloig le 40 nóiméad? :
- (e) 50 cm le 1½ méadar? :
- (f) 30 nóiméad le 1 uair an chloig? :

①



Meascann tógálaí gaineamh agus stroighin sa chóimheas 4 : 1. Más 450 kg a bhí sa mheascán cén méid gainimh a d'úsáid sé?

②

Meascann tógálaithe gaineamh agus stroighin sa chóimheas 24 buicéad gainimh le 4 bhuicéad stroighin. Líon isteach, sna boscaí thíos, líon na mbuicéad a theastódh dá mbeidís ag iarraidh méideanna eile a dhéanamh, sa chóimheas céanna.

Gaineamh	Stroighin
3	:
6	:
12	:
24	: 4
36	:

Bean atá ag déanamh builín aráin sa bhaile úsáideann sí 1 chupán bainne agus 3 chupán plúir.

③



Dá mbeadh sí ag obair i mbácús cé mhéad cupán plúir a d'úsáidfeadh sí le 300 builín aráin a dhéanamh?

Dá mbeadh sí ag iarraidh aon bhuilín amháin a dhéanamh ach é dhá uair níos mó,

d'úsáidfeadh sí chupán bainne

agus chupán plúir.

Scríobh na cóimheasa seo a leanas san fhoirm is simplí.

①

(a) $3 \text{ g} : 8 \text{ g} = \square : \square$

(b) $5 \text{ l} : 15 \text{ l} = \square : \square$

(c) $30 \text{ cent} : 25 \text{ cent} = \square : \square$

(d) $8 \text{ cm} : 24 \text{ cm} = \square : \square$

(e) $€12 : €8 = \square : \square$

②

(a) $50 \text{ cm} : 2 \text{ m} = \square : \square$

(b) $2\frac{1}{2} \text{ l} : 10 \text{ l} = \square : \square$

(c) $80 \text{ cent} : 20 \text{ cent} = \square : \square$

(d) $2 \text{ mhí} : 1 \text{ bhliain} = \square : \square$

(e) $€2.50 : €2 = \square : \square$

③

Roinn

(a) €2 sa chóimheas 3 : 5

$\square : \square$

(b) 1½ uair sa chóimheas 4 : 5

$\square : \square$

(c) 1 kg sa chóimheas 8 : 2

$\square : \square$

(d) €56 sa chóimheas 4 : 3

$\square : \square$

(e) €40 sa chóimheas 2 : 3

$\square : \square$

(f) €1.20 sa chóimheas 7 : 5

$\square : \square$

(g) 2 mhéadar sa chóimheas 5 : 3

$\square : \square$

(h) 1 uair sa chóimheas 1 : 3

$\square : \square$

(i) €200 sa chóimheas 1 : 4

$\square : \square$

(j) €24 sa chóimheas 2 : 1

$\square : \square$



- ① Íocann Pól 30 cent ar sciar de thicéad lotto €1 agus íocann Doireann 70 cent.
- (a) Cén cóimheas ina roinnfear duais €5,500 eatarthu?
- (b) Cé mhéad a gheobhaidh gach duine den bheirt?
- ② Roinn €60 idir bheirt pháistí ionas go bhfaighidh páiste amháin a 4 oiread is a gheobhaidh an páiste eile.
- ③ Tuilleann Sorcha €3 in aghaidh gach €2 a thuilleann Treasa. Más €66 a thuilleann Treasa, cé mhéad a thuilleann Sorcha?
- ④ Roinn Diarmaid agus Póilín suim airgid sa chóimheas 8 : 1. Fuair Diarmaid €4.80. Cén tsuim airgid a bhí le roinnt ?
- ⑤ Roinn Tomás agus Ciara suim airgid sa chóimheas 4 : 5. Fuair Tomás €5. Cé mhéad a fuair Ciara?

Céatadán

Aonad Amháin = 100%

10% scáthaithe

1% scáthaithe

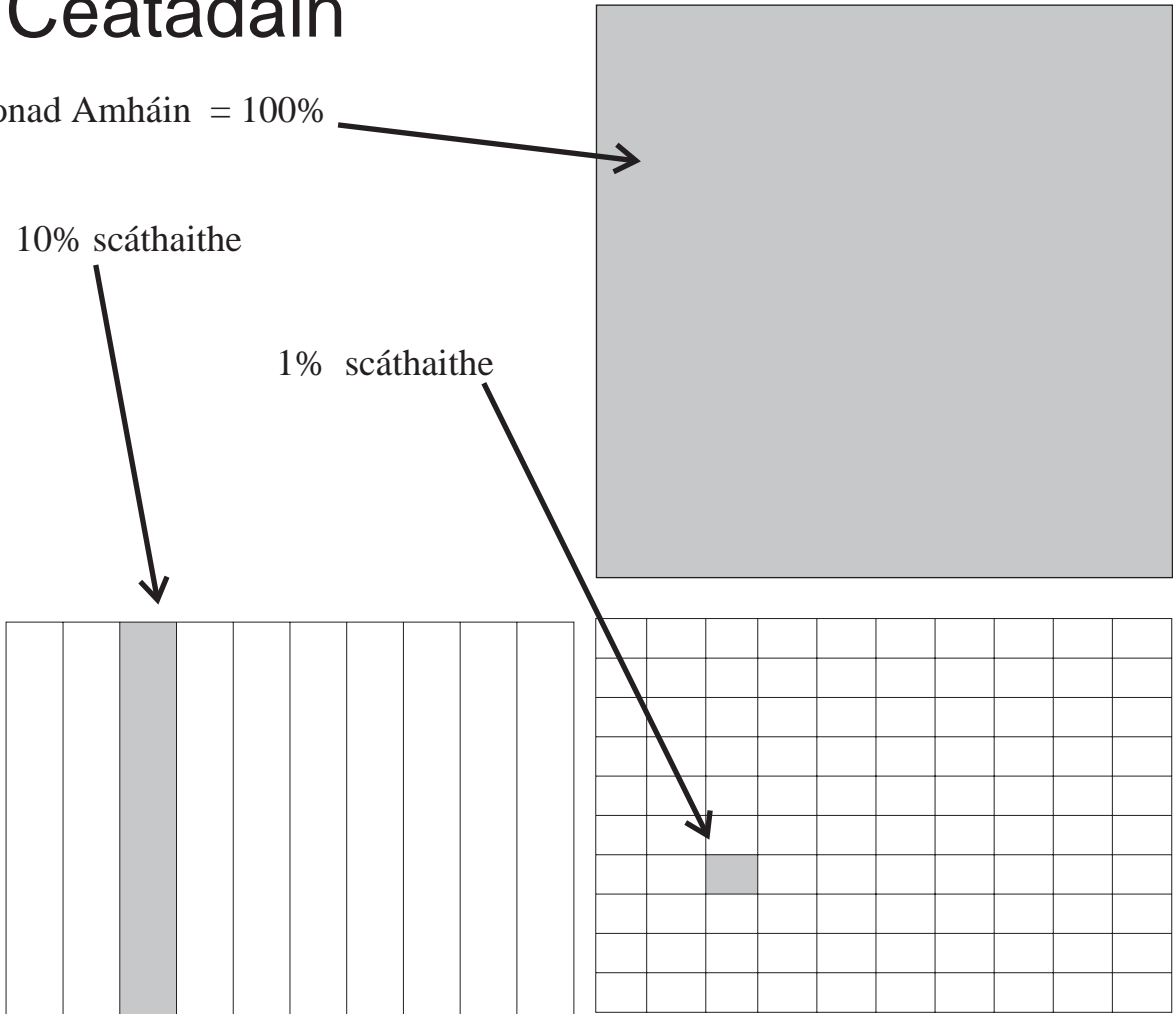

100%	10%	1%
100 cent	10 cent	1 cent
€1.00	€0.10	€0.01
1.0	0.1	0.01

% a scríobhtar.

“Faoin gcéad” a deirtear.

“as 100” atá i gceist le faoin gcéad nó “per cent”.

10 as 100 atá i gceist le 10%. (deich as céad).

1 as 100 atá i gceist le 1%. (a haon as céad).

Céatadán is ea 10% nó 1% nó uimhir ar bith a bhfuil an tsiombail % ina diaidh

Cén céatadán de gach aonad atá scáthaithe? Rinneamar an chéad cheann duit.

34% den aonad atá scáthaithe.

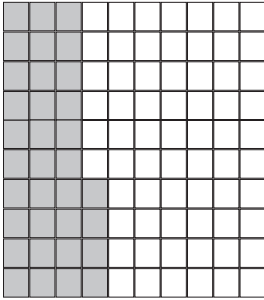

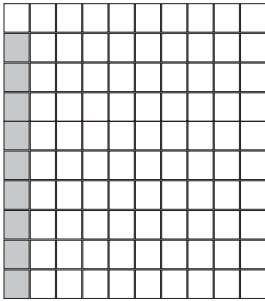
①  % den aonad atá scáthaithe.

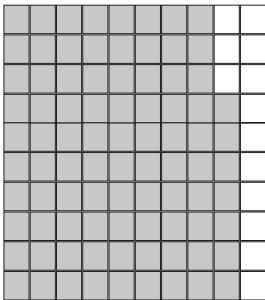
②  % den aonad atá scáthaithe.

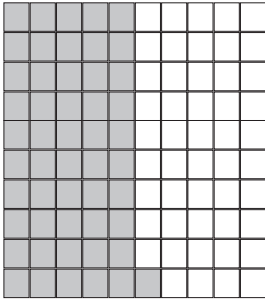
③  % den aonad atá scáthaithe.

Cén céatadán de gach aonad iomlán atá scáthaithe?

①

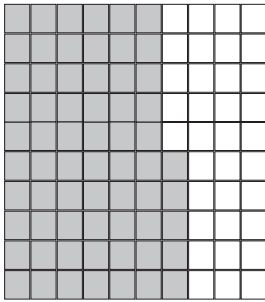

%

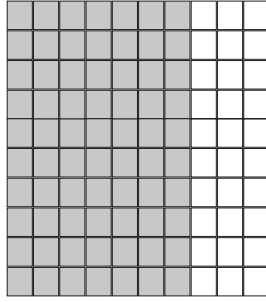

%

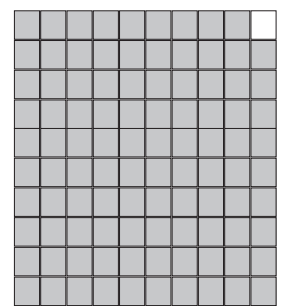

%

②

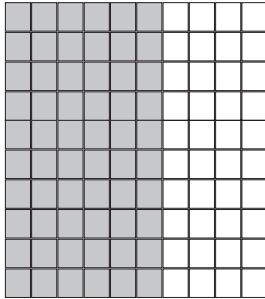

%

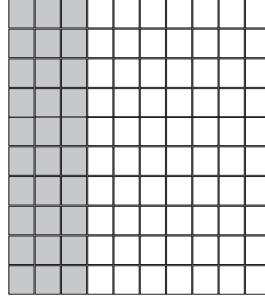

%

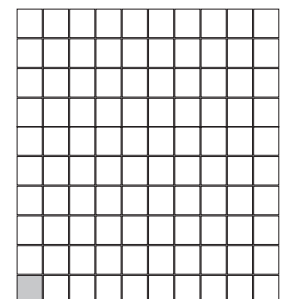

%

③

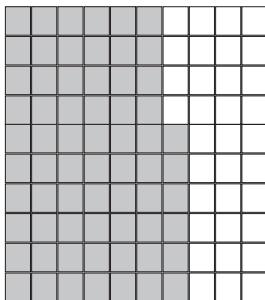

%

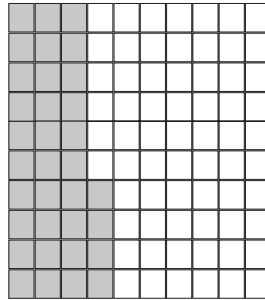

%

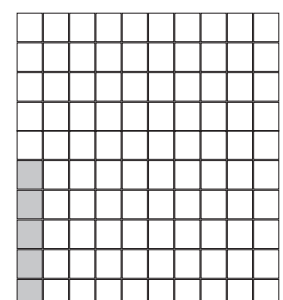

%

④

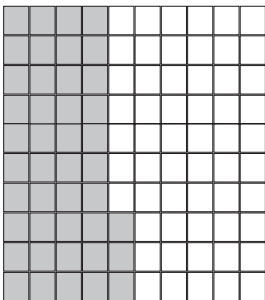

%

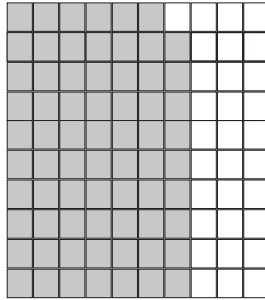

%

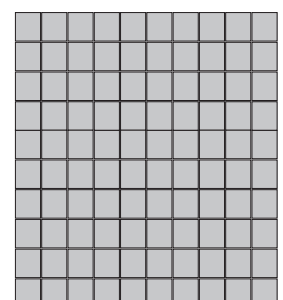

%

Scríobh na céatadáin seo ina ndeachúlacha. Rinneamar an chéad cheann duit.

①

(a) $6\% = 0.06$

(b) $17\% =$

(c) $2\% =$

(d) $25\% =$

(e) $20\% =$

②

(a) $80\% =$

(b) $8\% =$

(c) $18\% =$

(d) $9\% =$

(e) $90\% =$



Uillinn dhíreach = 180° .

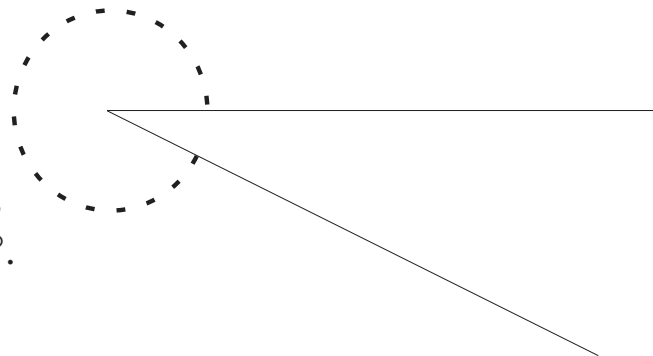

Bíonn uillinn athfillteach níos mó ná 180° ach níos lú ná 360° .

Scríobh gach suim airgid anseo thíos ina céatadán de €. Rinneamar an chéad cheann duit.

①

(a) 6 cent =

(b) 17 cent =

(c) 2 cent =

(d) 25 cent =

(e) 20 cent =

②

(a) 80 cent =

(b) 8 cent =

(c) 18 cent =

(d) 9 cent =

(e) 90 cent =



$$\text{Achar triantáin} = \frac{\text{bun} \times \text{airde}}{2}$$

Is iad 1, 3, 6, 10 na chéad uimhreacha triantánacha.

Codán a iompú ina chéatadán.Iompaigh $\frac{3}{4}$ ina chéatadán. $\frac{3}{4}$ = trí ceathrú d'aonad.Aonad iomlán amháin = $100/100$
nó 100%Ná dearmad gurb ionann “de” agus
“méadaithe faoi”.

$$\begin{aligned} \text{Mar sin } \frac{3}{4} \text{ de } 100 &= \frac{3}{4} \times 100 \\ &= \frac{3}{4} \times \frac{100}{1} \\ &= \frac{75}{1} = 75 \end{aligned}$$

Déan iad seo thíos, ar an mbealach céanna.
Iompaigh na codáin seo ina gcéatadán.Déan iad seo thíos.
Iompaigh na céatadán ina
gcodáin ar dtús.

① (a) $\frac{1}{5} =$

(b) $\frac{3}{10} =$

(c) $\frac{4}{5} =$

(d) $\frac{1}{4} =$

(e) $\frac{3}{5} =$

(f) $\frac{7}{10} =$

(g) $\frac{1}{2} =$

(h) $\frac{9}{10} =$

② (a) 25% de 120 =

(b) 60% de 110 =

(c) 75% de 72 =

(d) 100% de 93 =

(e) 70% de 30 =

(f) 5% de 40 =

(g) 20% de 45 =

(h) 50% de 90 =

Cén céatadán de gach aonad iomlán atá scáthaithe? Scríobh na freagraí ina ndeachúlacha agus ina gcéatadáin. Rinneamar an chéad cheann duit.

0.34 nó 34% den aonad atá scáthaithe.

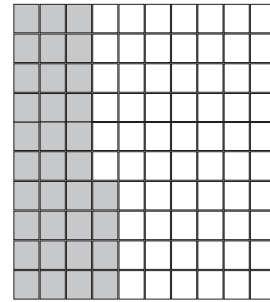

Ná dearmad an comhartha %.

①

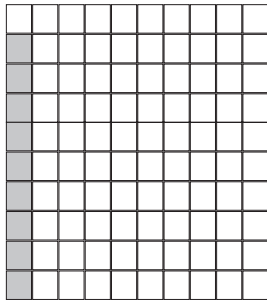

nó

den aonad atá scáthaithe.

②

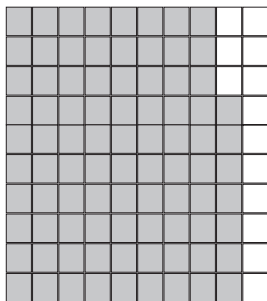

nó

den aonad atá scáthaithe.

③

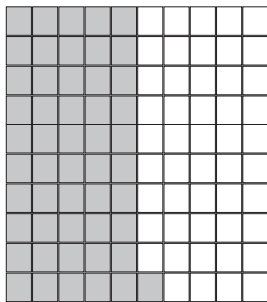

nó

den aonad atá scáthaithe.

$$25\% = \frac{25}{100} = 0.25$$

Iompaigh na céatadáin seo ina ndeachúlacha anois.

①

(a) $8\% =$

(b) $15\% =$

(c) $35\% =$

(d) $24\% =$

(e) $90\% =$

(f) $5\% =$

(g) $9\% =$

(h) $11\% =$

Líon isteach na boscaí.

②

(a) $0.03 =$ %

(b) $0.08 =$ %

(c) $0.01 =$ %

(d) $0.32 =$ %

(e) $0.87 =$ %

(f) $0.19 =$ %

(g) $0.74 =$ %

(h) $0.02 =$ %

Agus céatadán á lorg againn caithfimid nithe a athrú go dtí an t-aonad céanna

e.g. m cm

€ cent

kg g

uaireanta nóiméid

Sampla: Cén céatadán de 5 m é 50 cm?

5 mhéadar a athrú ina cm.

5 m = 500 cm

D'fhéadfaimis é a scríobh mar seo anois:

Cén céatadán de 500 cm é 50 cm

$$\frac{50}{500} \times \frac{100}{1} = 10$$

Freagra: 10%

①

(a) Laghdaigh €162 10%

(b) Laghdaigh €86 50%

(c) Laghdaigh €196 40%

(d) Laghdaigh €36 75%

②

(a) Méadaigh €450 10%

(b) Méadaigh €79 100%

(c) Méadaigh €320 90%

(d) Méadaigh €290 70%

Athraigh go dtí an t-aonad céanna iad seo thíos, faoi mar a rinneamar ar an leathanach roimhe seo.

- ①
- (a) Cén céatadán de €1 é 25 cent?
 - (b) Cén céatadán de m é $12\frac{1}{2}$ cm?
 - (c) Cén céatadán de 1 kg é 3 g?
 - (d) Cén céatadán de 1 kg é 800 g?
 - (e) Cén céatadán de €2.50 é 5 cent?
 - (f) Cén céatadán é 400 g de 2 kg?
 - (g) Cén céatadán é 80 g de 1 kg?
 - (h) Cén céatadán é 18 nóiméad d'uair an chloig?

Céatadáin dheacra a athrú ina gcodáin.

Sampla: Athraigh $33\frac{1}{3}\%$ ina chodán

$$\begin{aligned} \frac{33\frac{1}{3}}{100} &= \frac{33\frac{1}{3} \times 3}{100 \times 3} \\ &= \frac{(33 \times 3) + (3 \times \frac{1}{3})}{300} = \frac{100}{300} = \frac{1}{3} \end{aligned}$$

② Athraigh $62\frac{1}{2}\%$ ina chodán.

③ Athraigh $37\frac{1}{2}\%$ ina chodán.

Foghlaim an tábla seo agus cabhróidh sé go mór leat sa Mhata i Rang 5.

Codán		Deachúil		Céatadán
$\frac{1}{10}$	=	0.1	=	10%
$\frac{1}{8}$	=	0.125	=	$12\frac{1}{2}\%$
$\frac{1}{5}$	=	0.2	=	20%
$\frac{1}{4}$	=	0.25	=	25%
$\frac{3}{10}$	=	0.3	=	30%
$\frac{1}{3}$	=	0.333	=	$33\frac{1}{3}\%$
$\frac{3}{8}$	=	0.375	=	$37\frac{1}{2}\%$
$\frac{2}{5}$	=	0.4	=	40%
$\frac{1}{2}$	=	0.5	=	50%
$\frac{3}{5}$	=	0.6	=	60%
$\frac{5}{8}$	=	0.625	=	$62\frac{1}{2}\%$
$\frac{2}{3}$	=	0.666	=	$66\frac{2}{3}\%$
$\frac{7}{10}$	=	0.7	=	70%
$\frac{3}{4}$	=	0.75	=	75%
$\frac{4}{5}$	=	0.8	=	80%
$\frac{7}{8}$	=	0.875	=	$87\frac{1}{2}\%$
$\frac{9}{10}$	=	0.9	=	90%
$\frac{10}{10}$	=	1	=	100%

Aonad iomlán = 100%



Codán ar bith a bhfuil an t-uimhreoír agus an t-ainmneoir céanna aige, is ionann é agus 1 aonad amháin.

Sampla: $\frac{4}{4} = \frac{7}{7} = \frac{9}{9} = \frac{100}{100} = 1$ Aonad = 100 %

Ar fhoghlaim tú an tábla ar an leathanach roimhe seo de ghlanmheabhair? Lión isteach na huimhreacha atá in easnamh. Luachanna coibhéiseacha atá i ngach colún ar leith.

①

Codán	$\frac{1}{10}$			$\frac{1}{4}$		
Deachúil		0.125			0.3	
Céatadán			20%			$37\frac{1}{2}\%$

②

Codán	$\frac{2}{5}$			$\frac{1}{3}$		
Deachúil		0.5				0.625
Céatadán			60%			

③

Codán	$\frac{2}{3}$			$\frac{4}{5}$		
Deachúil		0.7				0.875
Céatadán			75%			



Agus tú ag méadú faoi 100

Bogann na digití dhá áit ar chlé.

e.g. $1.48 \times 100 = 148$

① Líon isteach na praghsanna laghdaithe

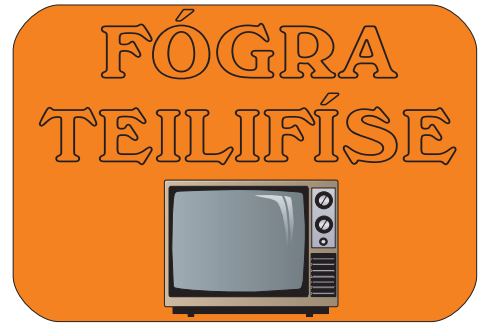

Laghdú 10% ar na praghsanna uile.

	Seanphraghas	Praghas Laghdaithe
Cótaí	€114	
Cótaí Báistí	€17	
Cultacha Fir	€218.50	
Seaicéid	€107.60	
Bróga	€58.70	
Slipéir	€4.80	
Fallaingeacha Seomra	€25.20	

Cé acu is mó? Cuir tic ✓ leis an luach is mó as gach péire.

	A		B	
①	Trí cheathrú de €60	✓	Dhá thrían de €51	
②	20% de 40		$\frac{1}{4}$ de 50	
③	Trí dheichiú de 50		0.3 de 60	
④	70% de 70		$\frac{3}{4}$ de 80	
⑤	$\frac{2}{5}$ de €60		$\frac{5}{8}$ de €40	
⑥	12½ % de 48		$\frac{9}{10}$ de 10	
⑦	0.666 de 90		$\frac{5}{8}$ de 100	
⑧	$\frac{4}{5}$ de 80		62½ % de 100	
⑨	$\frac{7}{8}$ de 56		25% de 200	
⑩	$\frac{7}{8}$ de 1		90% de 1	

Torthaí Scrúdaithe	
An Mhatamaitic	84 as 100
An Ghaeilge	44 as 50
An Stair	56 as 80
An Tíreolaíocht	42 as 70



Fuair Tomás na marcanna thuas i Scrúduithe na Nollag.

Cé acu ábhar is fearr a chruthaigh sé ann?

Iompaigh na marcanna ina gcéatadáin agus féach cad a tharlaíonn.

(Féach siar ar Leathanach 10-6 go bhfeice tú conas codáin a iompú ina gcéatadáin.)

①

Torthaí Scrúdaithe	
An Mhatamaitic	%
An Ghaeilge	%
An Stair	%
An Tíreolaíocht	%

② An bhfuil sé níos éasca an tuairisc seo a thuiscint?

Tá

Níl

Cén fáth?

①



Líon isteach na céatadáin ar an tuairisc seo.

Torthaí Scrúdaithe		
An Mhatamaitic	84 as 120	%
An Béarla	63 as 70	%
An Stair	48 as 75	%
An Tíreolaíocht	54 as 90	%
An Ghaeilge	72 as 80	%

Is minic a íocaimid táille seirbhíse agus béile á chaitheamh againn i mbialann.

Sampla: Más é $12\frac{1}{2}\%$ ráta na táille seirbhíse, ríomh an táille seirbhíse a chaithfidh tú a íoc ar bhéile a chosain €40.00.

$$12\frac{1}{2}\% = \frac{1}{8}$$

$$\begin{array}{r} 8 \overline{)40} \\ \underline{5} \end{array}$$

Cuirfear táille seirbhíse €5 leis an mbille.

Ciallaíonn ‘ingearach’ go bhfuil rud ‘dronuilleach’ le rud eile.

Ná Dearmad

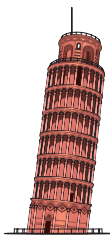

Níl Túr Claonta Pisa ingearach leis an talamh.

- ① Cé acu is mó? Cad é an difríocht eatarthu?
40% de €50 nó 20% de €90.
- ② Luach €25,000 a bhí ar shaothar dealbhóireachta 10 mbliana ó shin. Tá ardú $33\frac{1}{3}$ % tagtha ar a luach ó shin. Cén luach atá air anois?
- ③ Mhéadaigh déirí a tháirgeadh de bhainne pacáilte 5%. Táirgeann sé 162,750 lítear bainne in aghaidh an lae anois. Cén táirgeadh laethúil a bhí acu roimh an ardú.
- ④ Tá 540 oibrí i monarcha. Fir is ea 30% díobh.
- (a) Cé mhéad fear atá sa mhonarcha?
- (b) Cé mhéad bean atá sa mhonarcha?
- (c) Cén céatadán de na hoibrithe ar mná iad?
- ⑤ Tá 760 dalta i scoil.
Bhí $2\frac{1}{2}$ % acu as láthair lá amháin.
Cé mhéad dalta a bhí i láthair ?



$$8 \text{ g} = 0.008 \text{ kg}$$

- ① Bhí 480 oráiste i mbosca. Bhí 15% acu lofa.

Cé mhéad oráiste maith a bhí ann?

- ② Thuill Pádraig €26,250 sa bhliain agus dhíol sé cáin 38%. Thuill Diarmaid €34,800 an bhliain chéanna agus dhíol sé cáin 15%.

Cén méid airgid de bhreis ar Phádraig a thug Diarmaid abhaile leis?

- ③ Tá 600 dalta i scoil.
Críochnaigh an taifead tinrimh thíos.

	Céatadán as láthair	Líon as láthair	Líon i láthair	Céatadán i láthair
Dé Luain	7%			
Dé Máirt	2%			
Dé Céadaoin	$1\frac{1}{2}$ %			
Déardaoin	3%			
Dé hAoine	5%			

- ④ Chaill Fíí 5% dá meáchan le sé mhí anuas. Meánn sí 57 kg anois.
Cén meáchan a bhí inti 6 mhí ó shin?

- ⑤ Chaith cailín 95% dá cuid airgid. Bhí €8 fágtha aici. Cén méid airgid a bhí aici ar dtús?

- ① Laghdaíodh praghas leabhair 10% i sladmhargadh. Más é €2.70 an praghas nua, cad é an seanphraghas?
- ② Gach uimhir sa tábla thíos is céatadán de 150 í. Tá céatadán amháin mícheart ach tá an chuid eile ceart.

(a) Scríobh an céatadán atá mícheart.

(b) Cén uimhir ba cheart a bheith ann?

10%	20%	30%	60%	80%
15	30	45	100	120

- ③ Bhí na torthaí seo a leanas ar díol ag díoltóir sa mhargadh:
400 úll, 100 banana, 80 pluma

Dhíol sé 90% de na húlla, 80% de na bananaí agus 60% de na plumaí.
Cé mhéad toradh de gach aon chineál nár éirigh leis iad a dhíol?

- ④ Tá 350 dalta i Scoil A. Tá 20% de bhreis ar sin i Scoil B.

Cé mhéad páiste atá i Scoil B?

- ⑤ €90 an duaischiste i gcomórtas scríbhneoireachta. Bhí 50% ag gabháil don 1ú duais, 30% don 2ú duais agus 20% don 3ú duais.

Cén luach airgid a bhí i ngach duais?

① Méadaigh €25 20%

② Méadaigh 1.6 m 75%

③ Méadaigh €1.20 25%

④ Méadaigh 70 kg 15%

⑤ Laghdaigh 5 kg 15%

⑥ Laghdaigh 16 kg $2\frac{1}{2}$ %

⑦ Laghdaigh €2.70 $33\frac{1}{3}$ %

Siméadracht

Cuir tic ✓ leis na cruthanna anseo thíos ar féidir iad a fhilleadh ionas go luífidh leath amháin anuas ar an leath eile go cruinn.

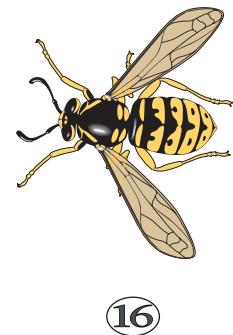
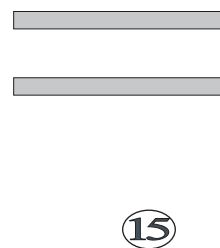
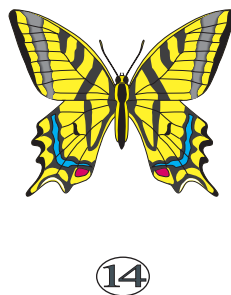
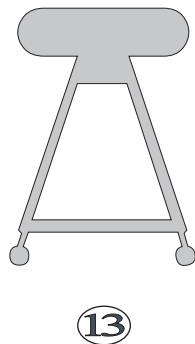
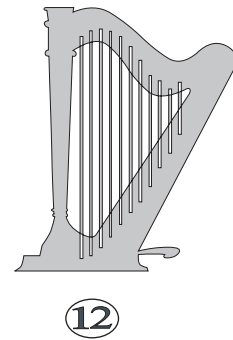
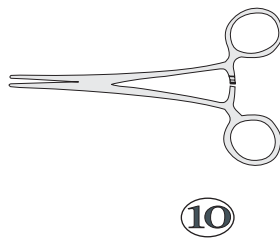
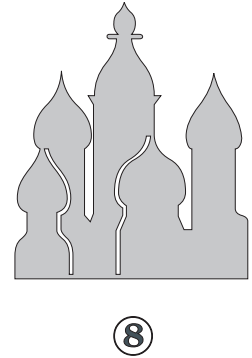
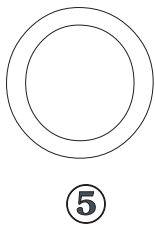
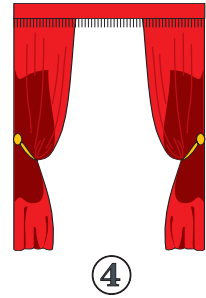
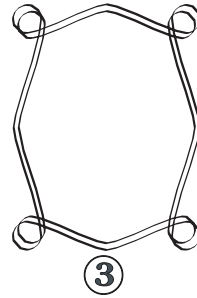
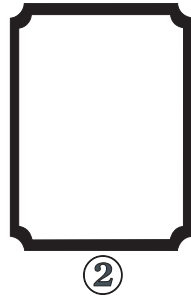
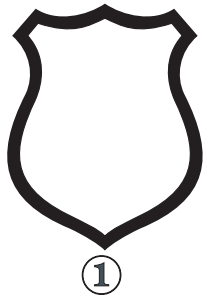

Is féidir an cruth seo a fhilleadh ar feadh na líne briste ionas go luífidh leath amháin ar an leath eile go cruinn.

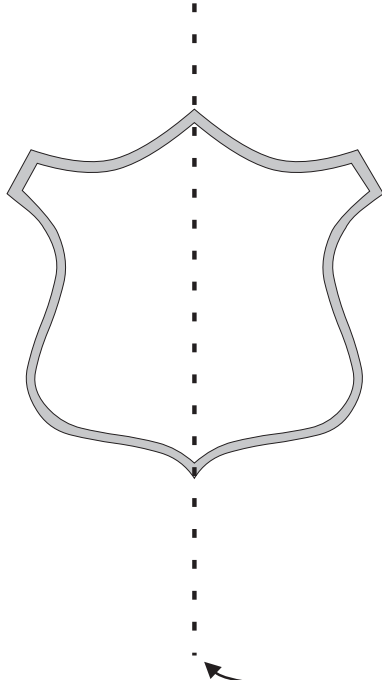

Ais na siméadrachta a thugtar ar an líne bhriste.

← Ais na siméadrachta

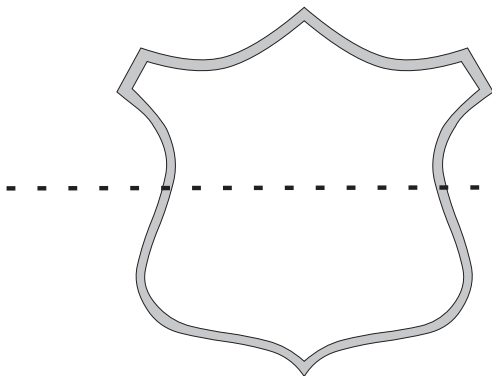

← Ní ais na siméadrachta í seo toisc **nach féidir** an leath uachtarach a fhilleadh ar an leath íochtarach go cruinn.

Ais siméadrachta amháin atá ag an gcruth seo, dá réir sin.

Tá sé siméadrach faoina ais ingearach.

① Marcáil ais na siméadrachta ar gach ceann de na cruthanna seo a leanas.

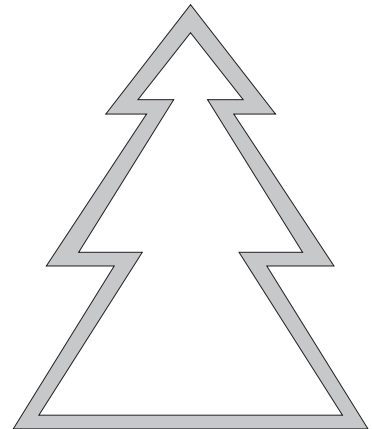
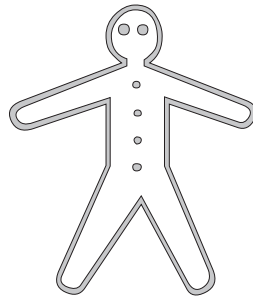
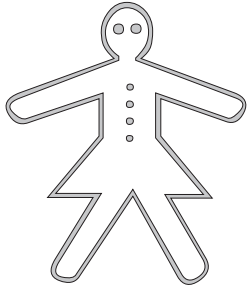

② Marcáil ais na siméadrachta ar gach ceann de na cruthanna seo a leanas.

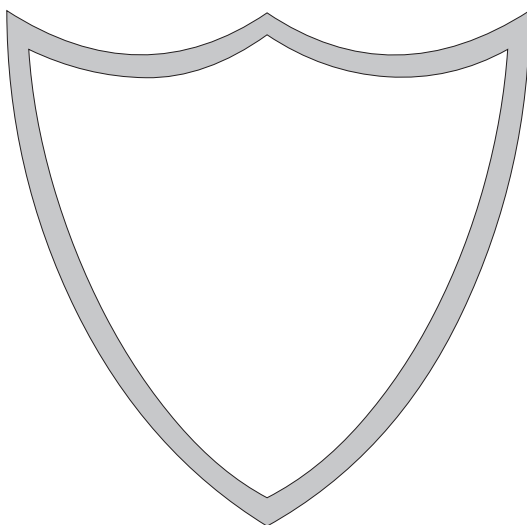
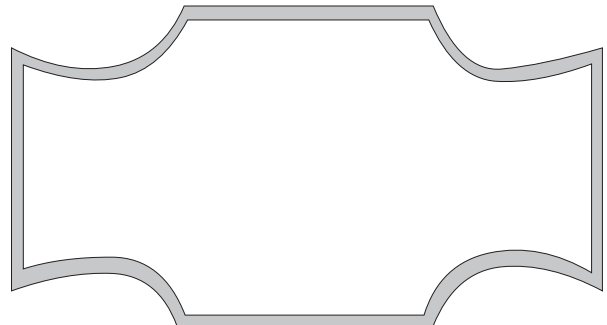
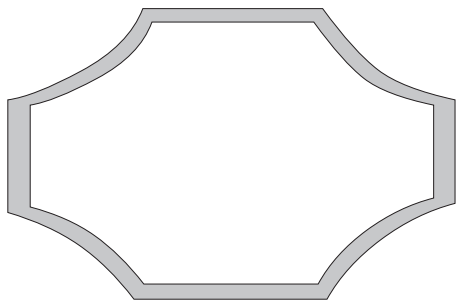

Tá breis is ais siméadrachta amháin ag na cruthanna thíos.

Marcáil gach ais le líne bhriste.

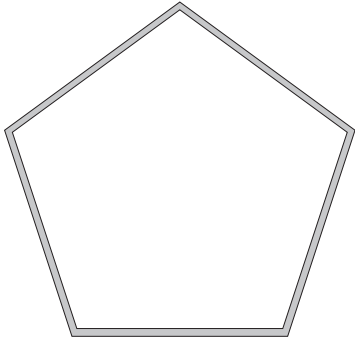

① Cé mhéad ais siméadrachta?

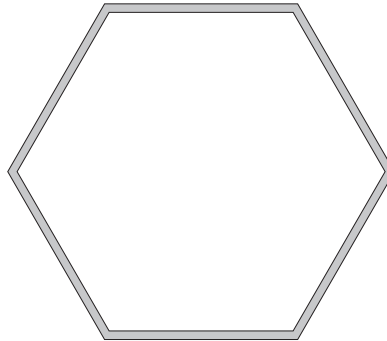

Cé mhéad ais siméadrachta?

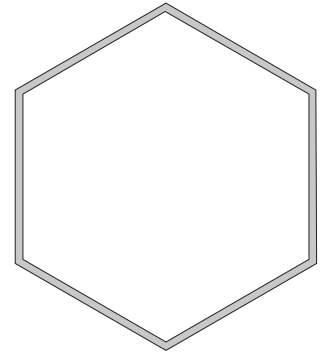

Cé mhéad ais siméadrachta?

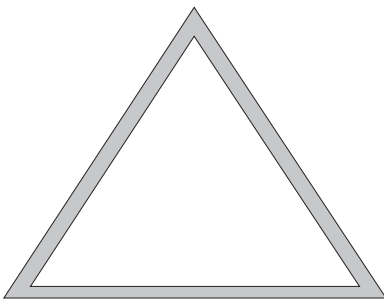

② Cé mhéad ais siméadrachta?



Cé mhéad ais siméadrachta?



③ Cé mhéad ais siméadrachta?

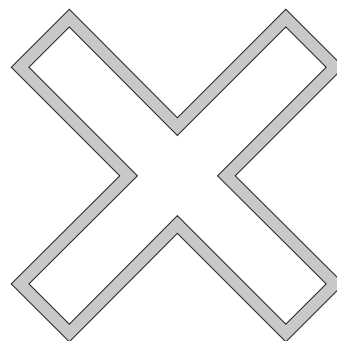

Cé mhéad ais siméadrachta?

Nótáil: Is é 'aiseanna' an t-íolra ar 'ais'.

Scáileanna

Leag scáthán ar feadh ais siméadrachta an phictiúir seo d'fhéileacán.

Scáil nó íomhá den leath eile atá le feiceáil sa scáthán.

Ábhar neamhscáileach

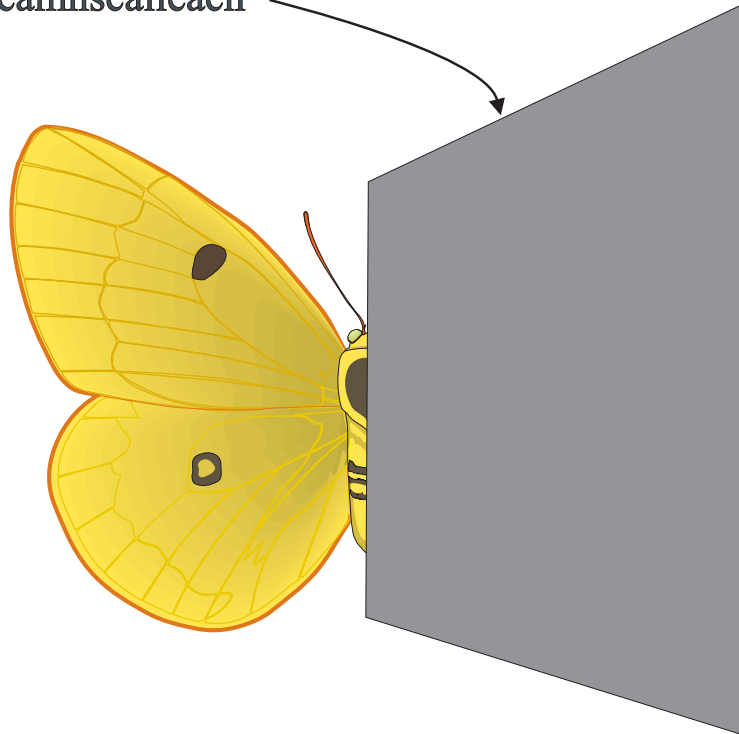

Scáthán

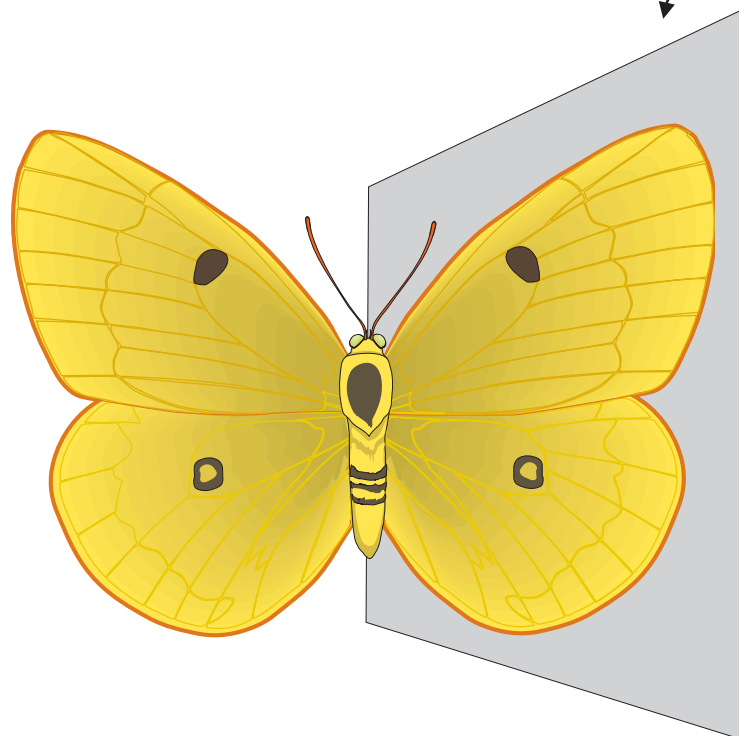

① Is í an líne bhriste ais na siméadrachta. Lión isteach an leath eile agus déan íomhá scáthánach.

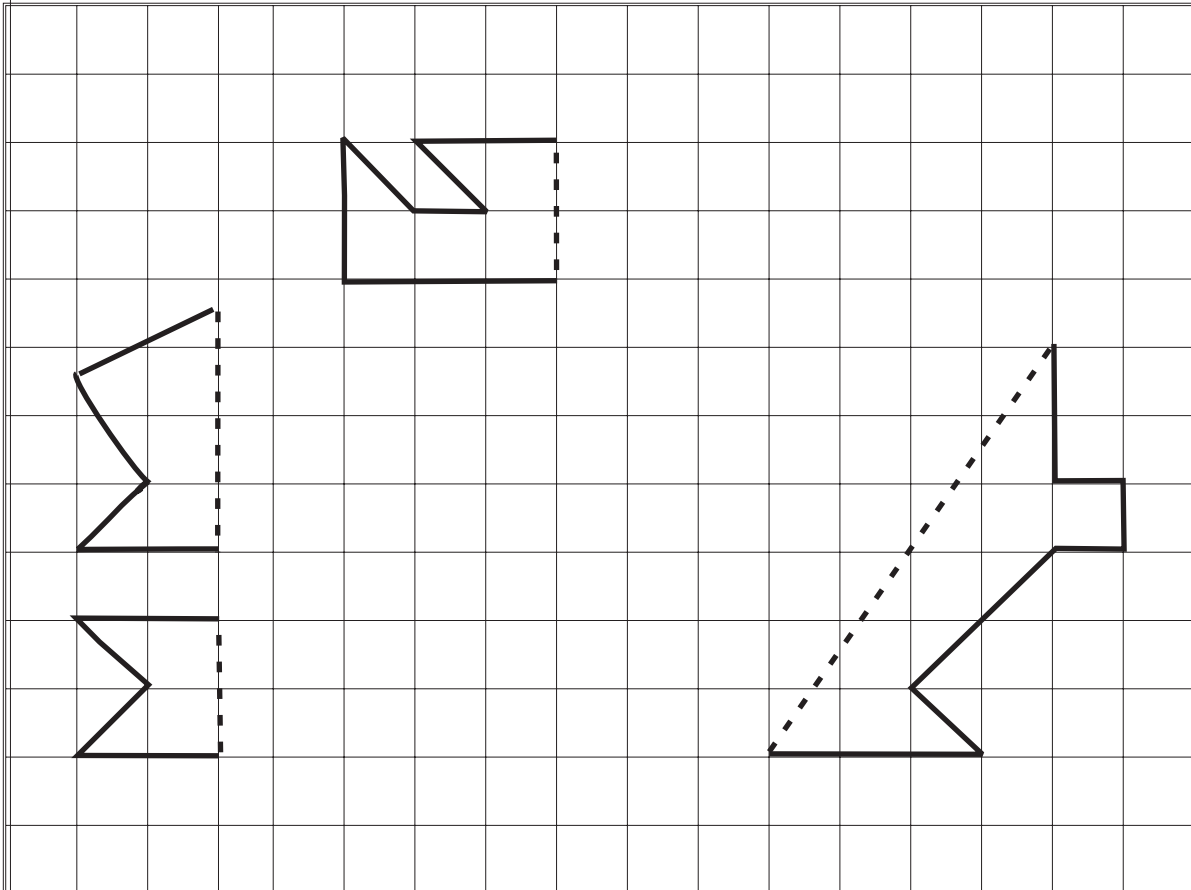
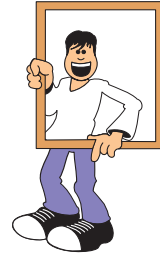

Marcáil na haiseanna siméadrachta go léir ar na dearaí thíos.

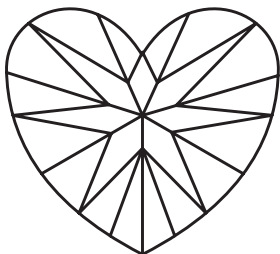

Siméadracht Rothlach

Más féidir cruth a rothlú ionas go gclúdóidh sé a imlíne féin deirtear go mbaineann Siméadracht Rothlach leis an gcruth.

(Más rothlú 360° an t-aon rothlú a chlúdódh an imlíne, áfach, deirtear **nach** mbaineann siméadracht rothlach leis.)

An mbaineann siméadracht rothlach leis an litir **S**? Breathnaímis.

Nótáil: Cuireadh ponc bán ar an **S** ar mhaithe le soiléire.

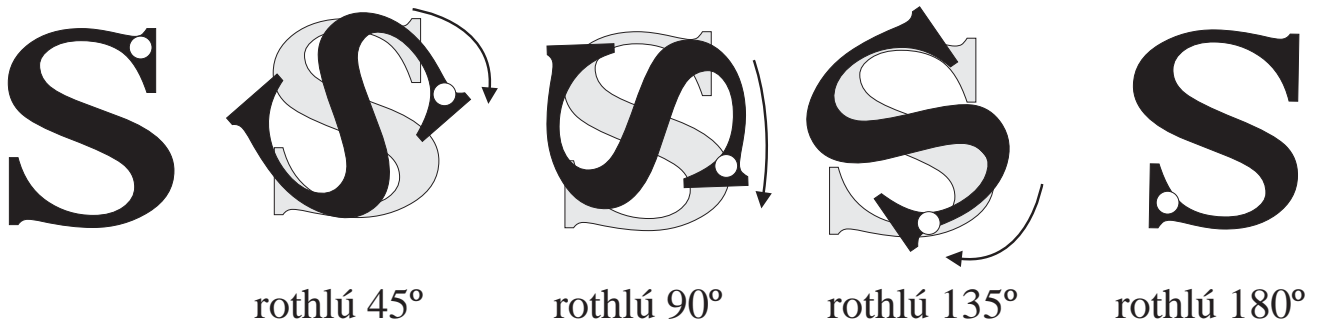

Clúdaíonn an **S** a imlíne agus rothlú 180° déanta. Baineann siméadracht rothlach leis, mar sin.

Ní bhaineann siméadracht rothlach leis an litir **A**. Is gá í a rothlú 360° le go gclúdódh sí a himlíne féin.

Tarraing an litir **N** ag ceithre staid rothlaithe.

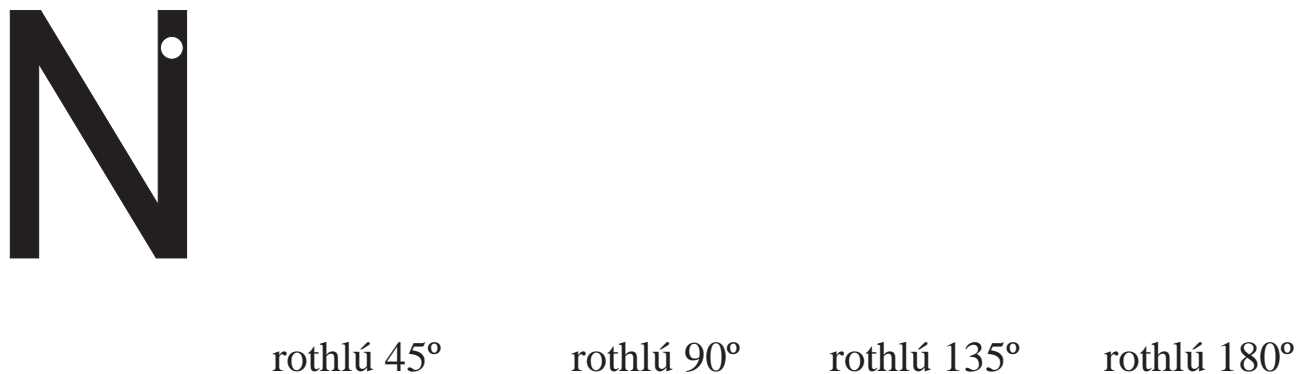

Má chasann tú roth rothair casfaidh sé nó rothlóidh sé timpeall ar an acastóir.

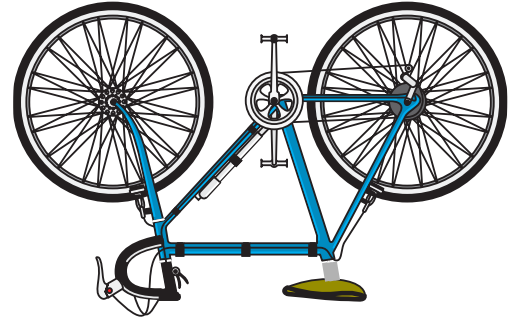

Agus muid ag caint anseo ar chruthanna a rothlú, caithfidh tú a shamhlú go bhfuil an cruth ag rothlú sa tslí chéanna timpeall ar acastóir *samhailteach* ina lár.

Abair go bhfuil tú ag iarraidh an cruth seo a rothlú trí 180°.

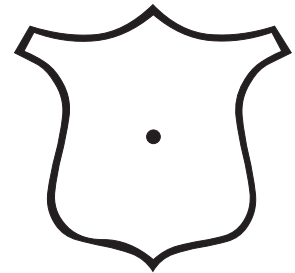
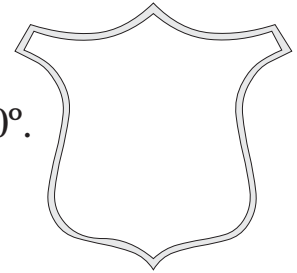

Samhlaigh, ar dtús, acastóir ina lár mar a bhfuil an ●.



Rothlaigh an cruth timpeall ar an acastóir samhailteach ansin.

①

Tarraing an cruth seo agus é iompaithe deiseal 90°.

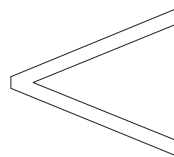

Críochnaigh an chéad chruth eile sna patrúin rothlaithe seo.

①

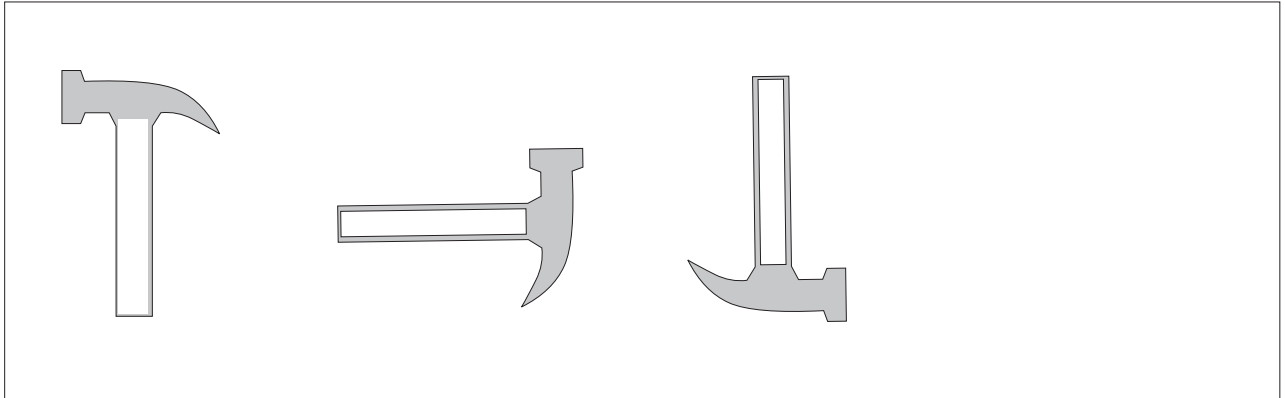

②

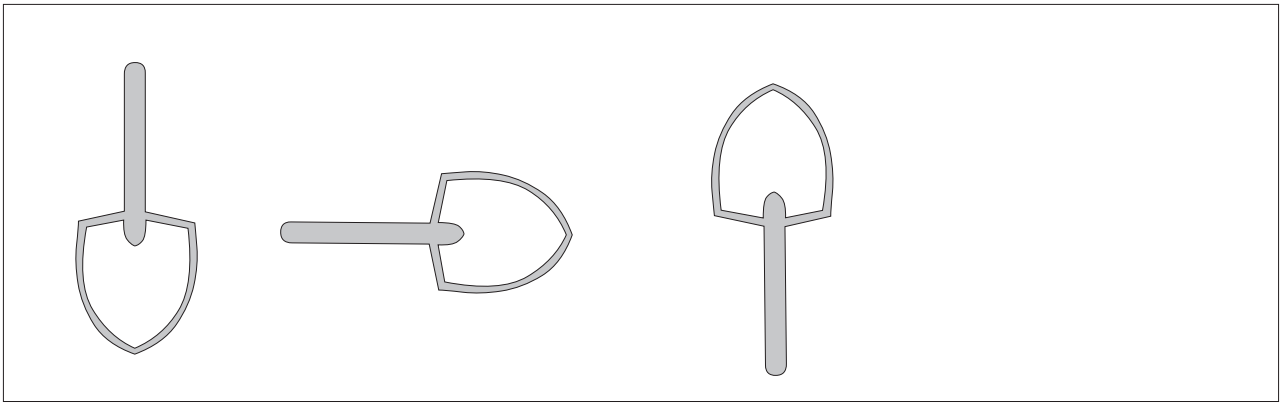

③

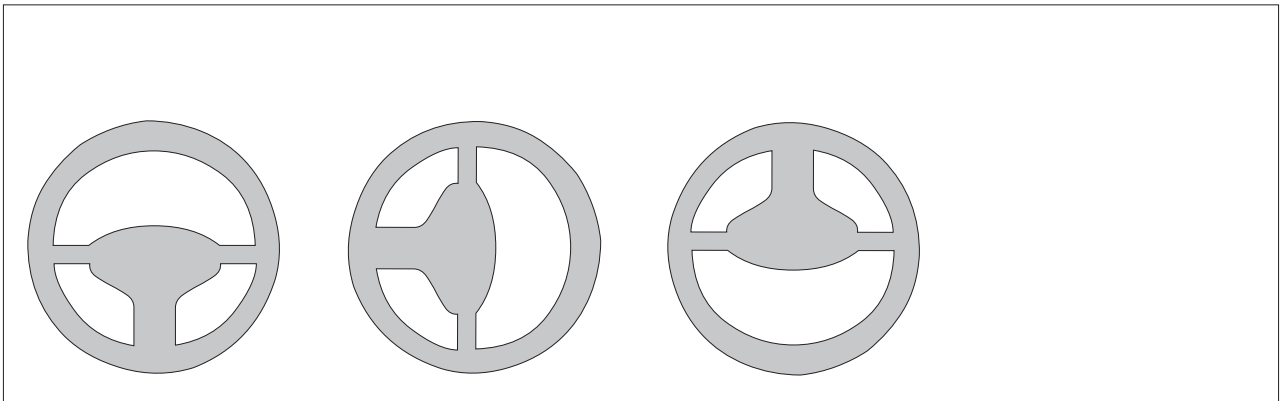

④

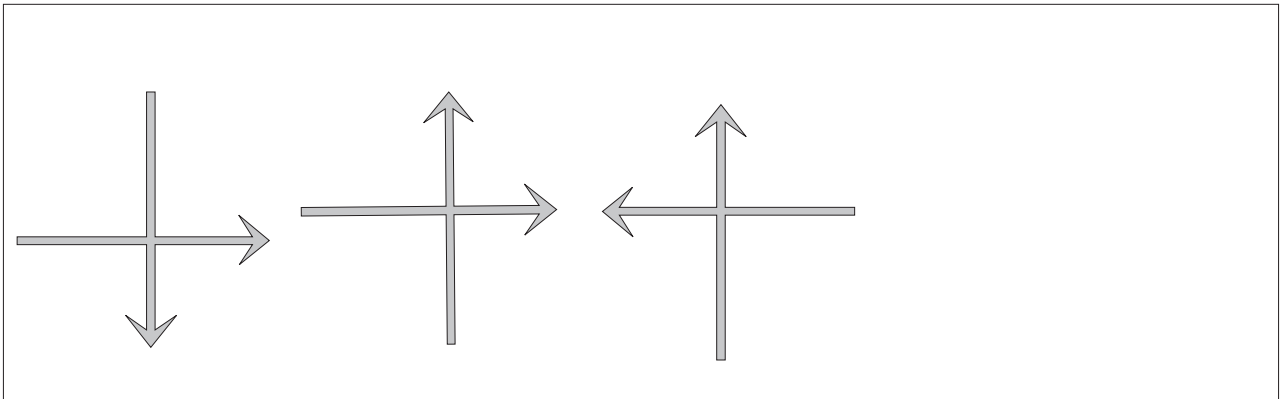

Cé na cruthanna a mbaineann siméadracht rothlaithe leo?

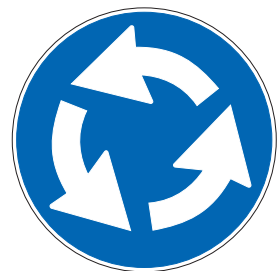

① (A)

(B)

(C)

(D)

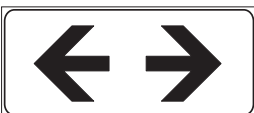

(E)

(F)

(G)

(H)

②

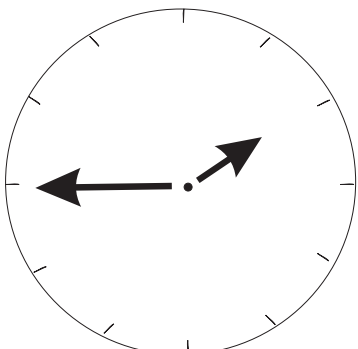

Ceathrú chun a dó

Dá mbreathnóimis ar an gclog seo i scáthán cén t-am a thaispeánfadh sé?

③

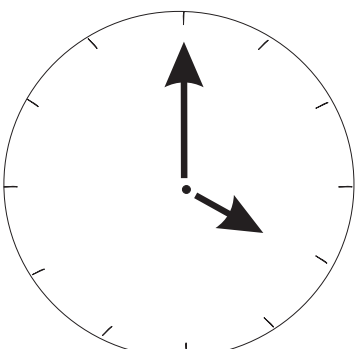

A ceathair a chlog

Dá mbreathnóimis ar an gclog seo i scáthán cén t-am a thaispeánfadh sé?

Séana

(nó Easpónaint)

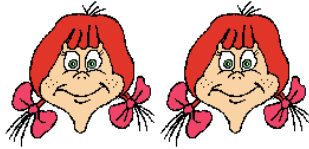

cúpla comhionann

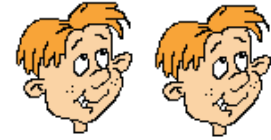

cúpla comhionann

$$2 \times 2 = 4$$

$$3 \times 3 = 9$$

$$4 \times 4 = 16$$

fachtóirí comhionanna

Is é 4 an toradh ar 2 fhachtóir **chomhionanna**.

Is é 9 an ar dhá fhachtóir .

Is é 16 an ar dhá fhachtóir .

$$2 \times 2 \times 2 = \text{[]}$$

$$3 \times 3 \times 3 = \text{[]}$$

$$4 \times 4 \times 4 = \text{[]}$$

Ná
Dearmad

Is é 'séana' an uimhir iolra ar 'séan'.

Mar seo a scríobhtar fachtóirí comhionanna :

	a scríobhtar	a deirtear
5×5	5^2	a cúig cearnaithe
$5 \times 5 \times 5$	5^3	a cúig ciúbaithe
$5 \times 5 \times 5 \times 5$	5^4	a cúig go dtí cumhacht a ceathair
$5 \times 5 \times 5 \times 5 \times 5$	5^5	a cúig go dtí cumhacht a cúig
$5 \times 5 \times 5 \times 5 \times 5 \times 5$	5^6	a cúig go dtí cumhacht a sé

séan

Séana a thugtar ar na huimhreacha beaga.

Deir an séan linn cé mhéad fachtóir atá ann.

Sampla: 3^5 Is é 5 an séan.

Tá a fhios againn, mar sin, go bhfuil 5 fhachtóir ann, mar seo a leanas:

$$3 \times 3 \times 3 \times 3 \times 3$$

Ná samhlaigh riamh go bhfuil $3^5 = 3 \times 5$

Féach chomh héagsúil is atá na freagraí

$$3^5 = 243$$

$$\text{Ach } 3 \times 5 = 15$$

① $4^3 = \square \times \square \times \square = \square$

② $5^4 =$

③ $4^5 =$

Athscríobh iad seo a leanas agus séana in úsáid agat.

①

(a) $7 \times 7 \times 7 \times 7$

(b) $9 \times 9 \times 9 \times 9 \times 9 \times 9 \times 9$

(c) $3 \times 3 \times 3 \times 3 \times 3 \times 3 \times 3 \times 3$

(d) 8×8

(e) $a \times a \times a$

(f) $b \times b \times b$

(g) $c \times c \times c \times c$

Nótáil: **An chumhacht** nó **an t-easpónant** a thugtar ar an séan uaireanta.

Sampla: 3^6 is ea a trí ardaithe go cumhacht a sé nó a trí i gcumhacht a sé.

②

Scríobh 125 mar chumhacht de 5.

Scríobh 81 mar chumhacht de 3.

Scríobh 1024 mar chumhacht de 4.

③

Faigh luach: $(2 \cdot 1)^2$ $(3 \cdot 6)^2$ $(1 \cdot 9)^2$

④

Faigh luach: $(0 \cdot 1)^3$ $(0 \cdot 5)^3$

Faigh luach gach ceann díobh seo.

①

	Luach
10^2	
9^4	
6^5	
4^5	
7^2	
8^5	
8^4	
3^7	
7^8	

Scríobh an comhartha ceart ($>$ = $<$),
anois, sna boscaí thíos.

②

- | | | | |
|-----|--------|----------------------|-------|
| (a) | 10^2 | <input type="text"/> | 8^2 |
| (b) | 9^2 | <input type="text"/> | 6561 |
| (c) | 6^2 | <input type="text"/> | 1296 |
| (d) | 4^2 | <input type="text"/> | 3^2 |
| (e) | 7^2 | <input type="text"/> | 50 |
| (f) | 8^2 | <input type="text"/> | 7^2 |

③ Faigh a gcuid luachanna seo, agus cuir
gach péire i gcomparáid le chéile.

(a) 8^4 8×4

(b) 7^3 7×3

(c) 5^5 5×5

(d) 6^3 6×3

(e) 2^8 2×8

(f) 8^2 8×2

Séana a Iolrú

Sampla 1: Iolraigh 2^2 faoi 2^3

$$2^2 = 2 \times 2$$

$$2^3 = 2 \times 2 \times 2$$

$$\begin{aligned} \text{Dá réir sin } 2^2 \times 2^3 &= (2 \times 2) \times (2 \times 2 \times 2) \\ &= (2 \times 2 \times 2 \times 2 \times 2) \\ &= 2^5 \end{aligned}$$

Sampla 2: Iolraigh 5^3 faoi 5^4

$$5^3 = 5 \times 5 \times 5$$

$$5^4 = 5 \times 5 \times 5 \times 5$$

$$\begin{aligned} \text{Dá réir sin } 5^3 \times 5^4 &= (5 \times 5 \times 5) \times (5 \times 5 \times 5 \times 5) \\ &= (5 \times 5 \times 5 \times 5 \times 5 \times 5 \times 5) \\ &= 5^7 \end{aligned}$$

Ar thug tú aon rud faoi deara?

I sampla 1 thuas: $2^2 \times 2^3 = 2^5$

I sampla 2 thuas: $5^3 \times 5^4 = 5^7$

Féach go suimimid na séana chun na huimhreacha a iolrú.

Ná
Dearmad

Ní fíor an riail sin ach amháin nuair is uimhreacha cosúla atá le hiolrú.

Scríobh iad seo a leanas gan ach séan amháin a úsáid i ngach cás.

①

(a) $3^3 \times 3^4 =$

(b) $6^8 \times 6^2 =$

(c) $2^4 \times 2^5 =$

(d) $10^1 \times 10^3 =$

(e) $8^4 \times 8^4 =$

(f) $9^3 \times 9^2 =$

(g) $7^2 \times 7^3 =$

(h) $5^1 \times 5^4 =$

(i) $4^8 \times 4^3 =$

②

Scríobh amach na freagraí mar uimhreacha. Ná bíodh séan iontu.

(a) $10^2 \quad 2^4 \quad 25^2 \quad 3^5$

(b) $10^3 \quad 7^2 \quad 8^4 \quad 9^3$

(c) $(3 \cdot 2)^2 \quad (4 \cdot 3)^2 \quad (5 \cdot 1)^2 \quad (7 \cdot 5)^2$

Bealach tapa le huimhir a chearnú a bhfuil an codán $\frac{1}{2}$ inti.

Sampla: Cearnaigh $4\frac{1}{2}$

Tabhair na huimhreacha go dtí an slánuimhir is gaire i.e. 4 agus 5.

Iolraigh na huimhreacha agus cuir $\frac{1}{4}$ leis ansin.

$$4 \times 5 = 20. \text{ Cuir } \frac{1}{4} \text{ leis anois. } 20 + \frac{1}{4} = 20\frac{1}{4}.$$

$$\text{Is ionann é agus } (4\frac{1}{2})^2 = 4\frac{1}{2} \times 4\frac{1}{2} = 20\frac{1}{4}.$$

$$\text{Sampla eile: } (6\frac{1}{2})^2 = 6\frac{1}{2} \times 6\frac{1}{2} = 42\frac{1}{4}.$$

① $(2 \cdot 3)^2 \times (3 \cdot 4)^2 =$

Tabhair faoi deara i gceist 1 nach bhfuil na huimhreacha cosúil le chéile. Dá bhrí sin, ní féidir an riail d'iolrú na séan a úsáid.

② $10^2 \times$ $= 900$

③ Scríobh 27 mar chumhacht de 3.

④ $8000 = 8 \times 10^x$ Cad dó a sheasann x ?

⑤ $6 \times 2^3 =$

⑥

(a) $5^3 \times 4 =$

(b) $10^2 \times 7 =$

(c) $10^3 \times 9 =$

(d) $2^5 \times 10 =$

(e) $11^2 \times 10 =$

Séana

Roinnt

Sampla 1:

Roinn 9^6 faoi 9^2

$$9^6 \div 9^2 = \frac{\cancel{9} \times \cancel{9} \times 9 \times 9 \times 9 \times 9}{\cancel{9} \times \cancel{9}}$$

$$= 9 \times 9 \times 9 \times 9$$

$$= 9^4$$

(tar éis duit cealú os cionn na líne agus faoi bhun na líne)

Sampla 2:

Roinn 3^7 faoi 3^2

$$3^7 \div 3^2 = \frac{\cancel{3} \times \cancel{3} \times 3 \times 3 \times 3 \times 3 \times 3}{\cancel{3} \times \cancel{3}}$$

$$= 3 \times 3 \times 3 \times 3 \times 3$$

$$= 3^5$$

(tar éis duit cealú os cionn na líne agus faoi bhun na líne)

Ar thug tú aon rud faoi deara?

I sampla 1 thuas:

I sampla 2 thuas:

Tabhair faoi deara go ndealaímid na séana agus roinnt á déanamh.

Ná
Dearmad

Ní fíor an riail seo ach amháin nuair is uimhreacha cosúla atá le roinnt.

① Scríobh iad seo a leanas gan ach séan amháin a úsáid i ngach cás.

(a)	$4^7 \div 4^5 =$	<input style="width: 50px; height: 25px;" type="text"/>
(b)	$5^6 \div 5^3 =$	<input style="width: 50px; height: 25px;" type="text"/>
(c)	$3^9 \div 3^4 =$	<input style="width: 50px; height: 25px;" type="text"/>
(d)	$10^4 \div 10^1 =$	<input style="width: 50px; height: 25px;" type="text"/>
(e)	$9^7 \div 9^2 =$	<input style="width: 50px; height: 25px;" type="text"/>
(f)	$7^3 \div 7^2 =$	<input style="width: 50px; height: 25px;" type="text"/>
(g)	$6^5 \div 6^3 =$	<input style="width: 50px; height: 25px;" type="text"/>
(h)	$8^4 \div 8^1 =$	<input style="width: 50px; height: 25px;" type="text"/>
(i)	$5^6 \div 5^2 =$	<input style="width: 50px; height: 25px;" type="text"/>
(j)	$2^4 \div 2^3 =$	<input style="width: 50px; height: 25px;" type="text"/>

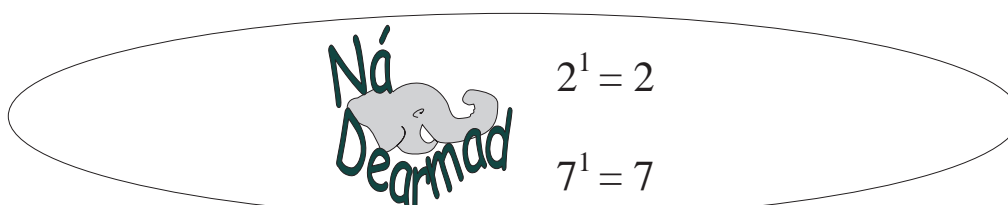

① Scríobh iad seo a leanas gan ach séan amháin a úsáid i ngach cás.

$$(a) \quad 10^5 \div 10^4 = \boxed{}$$

$$(b) \quad 7^5 \div 7^3 = \boxed{}$$

$$(c) \quad 8^7 \div 8^3 = \boxed{}$$

$$(d) \quad 6^4 \div 6^2 = \boxed{}$$

$$(e) \quad 8^{12} \div 8^5 = \boxed{}$$

② Faigh luach x sna cásanna seo a leanas.

$$(a) \quad 13^4 \div 13^2 = x$$

$$(b) \quad 18^4 \div 18^2 = x$$

$$(c) \quad 19^6 \div 19^3 = x$$

$$(d) \quad (3 \times 10^3) + (7 \times 10^4) + (8 \times 10^2) = x$$

An tAm

A chlog

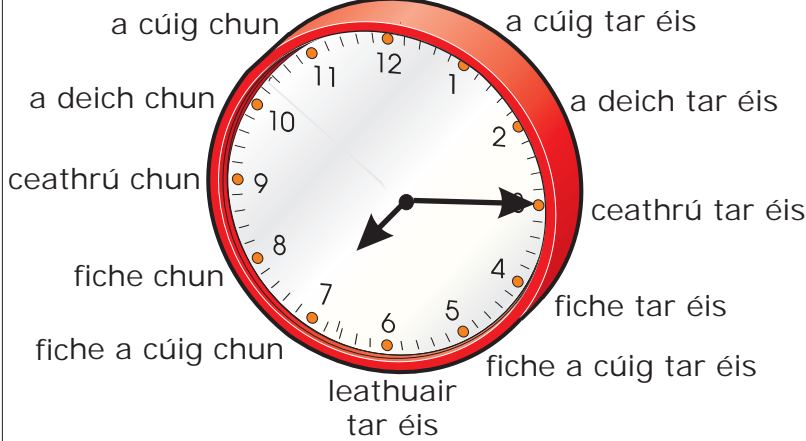

Is ionann 20 nóiméad chun a 8 agus 40 nóiméad tar éis a 7.

7.40 a scríobhaimid

Déan iad seo anois.

- ① a 5 tar éis a 11 =
- ② a 10 chun a 1 =
- ③ 20 chun a 8 =
- ④ a 10 tar éis a 9 =
- ⑤ $\frac{1}{4}$ tar éis a 3 =
- ⑥ $\frac{1}{2}$ uair tar éis 3 =
- ⑦ $\frac{1}{4}$ chun a 7 =
- ⑧ a 5 tar éis a 3 =
- ⑨ 25 tar éis a 12 =
- ⑩ a 5 chun a 9 =

Ná Dearmad

a.m.=

ó mheán oíche go dtí meán lae.

p.m.=

ó mheán lae go dtí meán oíche.

Scríobh an t-am agus é 20 nóiméad níos luaithe.



=

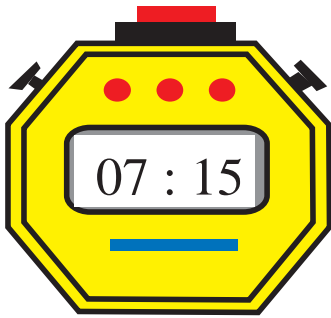

=



=



=



=



Meán lae a thugtar ar a 12 a chlog i lár an lae.

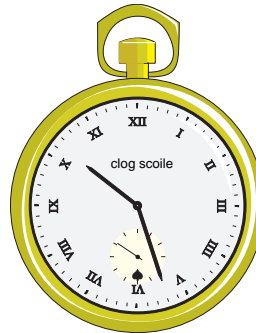
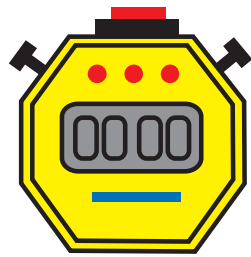

①

(a) 80 nóim. =	<input type="text" value="uair"/>	<input type="text" value="nóim."/>
(b) 120 nóim. =	<input type="text" value="uair"/>	<input type="text" value="nóim."/>
(c) 130 nóim. =	<input type="text" value="uair"/>	<input type="text" value="nóim."/>
(d) 155 nóim. =	<input type="text" value="uair"/>	<input type="text" value="nóim."/>
(e) 190 nóim. =	<input type="text" value="huaire"/>	<input type="text" value="nóim."/>

②

Cé mhéad nóiméad atá ann ó:

(a) 12.25 go dtí 1.15?

(b) 9.55 go dtí 10.15?

(c) 5.40 go dtí 6.20?

(d) 8.30 go dtí 9.15?

(e) 2.15 go dtí 2.45?

Ná Dearmad

$\frac{1}{5}$ d'uair = 12 nóiméad

$$\begin{array}{r} 5 \overline{)60} \\ \underline{50} \\ 10 \\ \underline{10} \\ 0 \end{array}$$

① Cé mhéad uair agus nóiméad atá ann ó:

(a) 7.10 p.m. go dtí 4.15 a.m.?

(b) 4.25 p.m. go dtí 2.20 a.m.?

(c) 5.30 p.m. go dtí 4.30 a.m.?

(d) 2.45 p.m. go dtí 1.10 a.m.?

(e) 7.20 p.m. go dtí 3.45 a.m.?

② Cé mhéad uair agus nóiméad ó:

(a) 10.30 p.m. go dtí 3.20 a.m.?

(b) 2.30 p.m. go dtí 1.50 a.m.?

(c) 9.30 p.m. go dtí 5.35 a.m.?

(d) 9.00 p.m. go dtí 8.25 a.m.?

(e) 4.00 p.m. go dtí 2.55 a.m.?



60 nóiméad = 1 uair an chloig

120 nóiméad = 2 uair an chloig

An Clog 24 uair

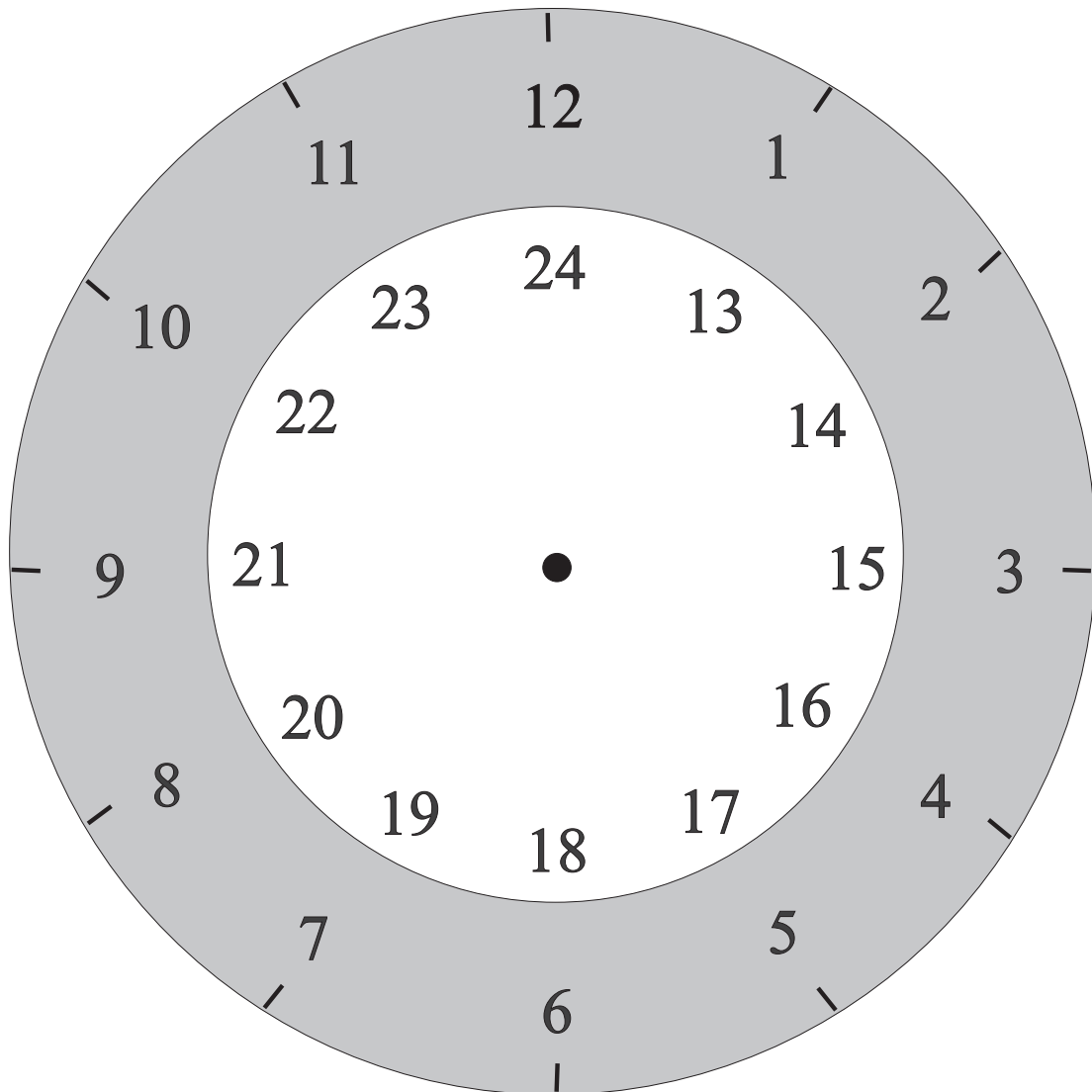

Níl gá le a.m agus p.m leis an gclog 24 uair, mar ní roinntear an lá ina dhá leath. Is ionann 1.00 p.m. (nó 1 san iarnóin) agus 13.00. Fágaimid an scoil ar 15.00 agus mar sin de.

Ceithre fhigiúr agus ponc a úsáidtear agus na tráthanna á scríobh ar an gclog 24 uair. Scarann an ponc na huairanta ó na nóiméid.

3.00 a.m. = 03.00

11.25 a.m. = 11.25

Nótáil: Idirstad (:) seachas ponc a bhíonn ar chloig dhigiteacha agus ar uaireadóirí digiteacha go minic, chun na huairanta a scaradh ó na nóiméid.

Scríobh na tráthanna seo a leanas don chlog 24 uair.

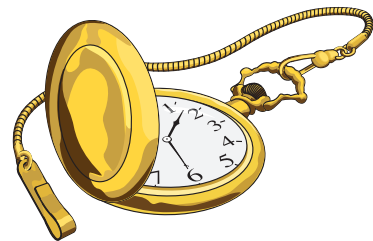
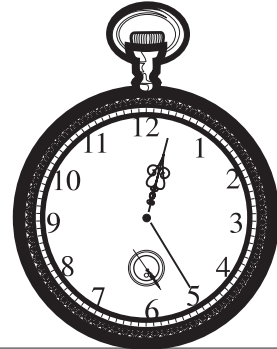

Tarraing lámha na gclog thíos.



08.15

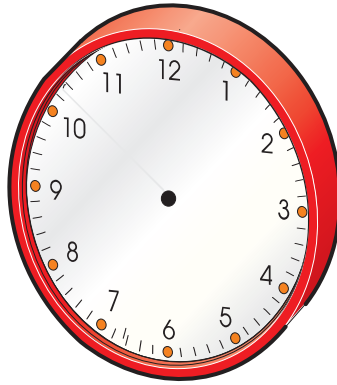

04.30

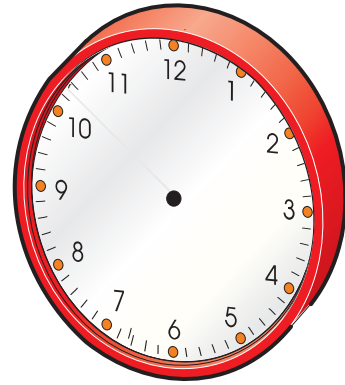

16.00

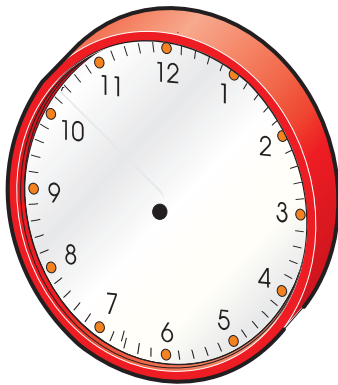

21.00



24.00

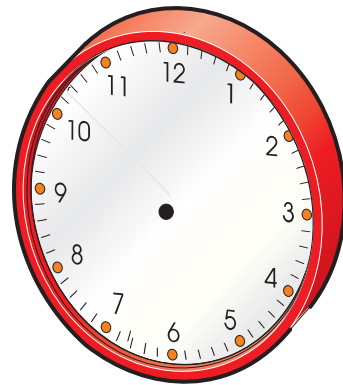

10.45



22.20

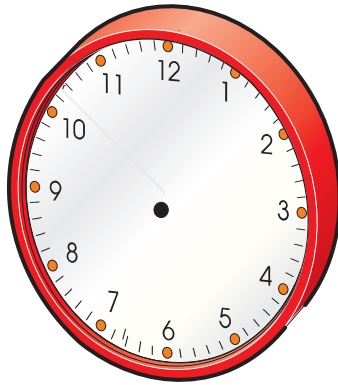

13.00

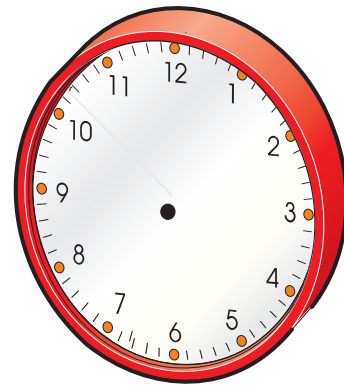

14.30

① Scríobh na hamanna thíos don chlog 24 uair.

- | | | |
|----------------|----------------|----------------|
| (a) 1.20 p.m. | (b) 7.30 p.m. | (c) 9.00 a.m. |
| (d) 10.00 a.m. | (e) 8.30 a.m. | (f) 12.08 a.m. |
| (g) 12.45 p.m. | (h) 11.10 a.m. | (i) 4.40 a.m. |

② Scríobh na hamanna seo a leanas sa chóras a.m. agus p.m.

- | | | |
|-----------|-----------|-----------|
| (a) 20.00 | (b) 01.50 | (c) 16.45 |
| (d) 12.25 | (e) 10.15 | (f) 14.10 |
| (g) 13.00 | (h) 00.07 | (i) 18.30 |

③ Londain go Baile Átha Cliath

Uimhir na hEitilte	Ag imeacht	Ag teacht isteach
FR 113	10.00	11.15
FR 115	13.30	14.45
FR 117	17.00	18.15
FR 119	20.30	21.45

- (i) Cén fad ama a thógann ann gach eitilt?
- (ii) Dá gcuirfí moill 55 nóiméad ar eitilt FR 115 cén t-am a shroichfeadh sí Baile Átha Cliath?
- (iii) Dá mbeifeá ag iarraidh a bheith i mBaile Átha Cliath ar a 2 p.m. cé acu eitilt ar a rachfá?

Ná
Dearmad

An clog 24 uair
a úsáidtear
d'Amchláir
Taistil.

4 huaire 35 nóiméad

6 huaire 50 nóiméad

10 n-uaire 85 nóiméad



Athghrúpáil 85 nóiméad = 1 uair 25 nóiméad.

10 n-uaire + 1 uair 25 nóiméad = 11 uair 25 nóiméad.

①

Uair	Nóim.
2	25
+ 6	55

②

Uair	Nóim.
3	18
+ 1	55

③

Uair	Nóim.
1	46
+ 4	28

④

Uair	Nóim.
	42
+ 2	54

⑤

Uair	Nóim.
3	17
+ 4	55

⑥

Uair	Nóim.
2	46
+ 3	45

52 seachtain = aon bhliain amháin



365 lá = 1 bhliain amháin

(366 lá i mbliain bhisigh. Cén fáth?)

① Faigh líon na n-uaireanta agus na nóiméad ó:

- | | | | |
|-----|-------|--------|-------|
| (a) | 06.15 | go dtí | 08.30 |
| (b) | 08.45 | go dtí | 11.00 |
| (c) | 10.20 | go dtí | 12.00 |
| (d) | 14.45 | go dtí | 18.00 |
| (e) | 14.30 | go dtí | 17.05 |
| (f) | 20.30 | go dtí | 23.10 |

② Suimigh chun do chuid freagraí a sheiceáil.

③ Úsáid a.m. nó p.m. i do chuid freagraí.

2 uair 15 nóiméad níos luaithe ná:

- | | | | | | |
|-----|------------|-----|------------|-----|-----------|
| (a) | 11.45 a.m. | (b) | 3.30 p.m. | (c) | 4.45 a.m. |
| (d) | 07.35 p.m. | (e) | 12.30 a.m. | (f) | 5.55 p.m. |

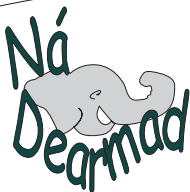

Uimhir atá níos mó ná a haon agus nach bhfuil fachtóirí ar bith aici seachas í féin agus a haon, is uimhir phríomha í, e.g. 3, 5, 7, 11.

Sampla:

uair	nóim.
7	20
- 5	35

Ní féidir 35 a bhaint ó 20,
mar sin athscríobh an t-am ar barr
san fhoirm 6 huair 80 nóim.

uair	nóim.
6	80
- 5	35
1	45

①

Uair	nóim.
3	10
-1	30

②

Uair	nóim.
4	12
-1	20

③

Uair	nóim.
5	6
-2	25

④

Uair	nóim.
4	10
-1	30

⑤

Uair	nóim.
3	25
-1	56

⑥

Uair	nóim.
8	29
-2	46

⑦

Uair	nóim.
7	35
-3	58

⑧

Uair	nóim.
9	45
-6	55

⑨

Uair	nóim.
10	06
-4	35

Déantar uaireanta agus nóiméid a dhealú faoin gcóras 24 uair freisin.

Sampla:

Cé mhéad uair agus nóiméad atá ann idir 9.15 a.m. agus 7.35 p.m.?

Scríobh an dá am faoin gcóras 24 uair an chloig ar dtús.

In áit 9.15 a.m. scríobh 09.15.

In áit 7.35 a.m. scríobh 19.35.

$$\begin{array}{r} 19.35 \\ - 09.15 \\ \hline 10.20 \end{array}$$

Freagra: 10 n-uaire 20 nóiméad.

Déan iad seo thíos ar an mbealach céanna.

① Cé mhéad uair agus nóiméad atá ann ó:

- (a) 11.25 a.m. go dtí 5.40 p.m.?
- (b) 10.56 a.m. go dtí 5.34 p.m.?
- (c) 8.56 a.m. go dtí 9.25 p.m.?
- (d) 6.35 a.m. go dtí 4.20 p.m.?

Ní hé an t-am céanna é gach áit ar domhan riamh!

Sampla:

Má tá sé 6 a.m in Éirinn tá sé 1 a.m. i Nua-Eabhrac agus 9.00 a.m. i Moscó.

Bíonn an t-am i Nua-Eabhrac 5 huair ar gcúl ar am na hÉireann, agus bíonn an t-am i Moscó 3 huair chun tosaigh ar am na hÉireann.

Líon na n-uaireanta chun tosaigh ar am na hÉireann.			
Páras	1	Shanghai	8
Perth	8	Tóiceo	9
Caireo	2	Moscó	3

Léiríonn an chairt thuas áiteanna atá roinnt uaireanta an chloig chun tosaigh orainn. Scríobh sna boscaí thíos an t-am áitiúil i gcomparáid le ham na hÉireann. Úsáid an córas 24 uair an chloig.

①

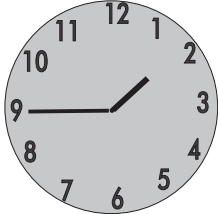
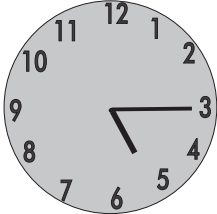
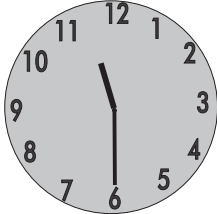
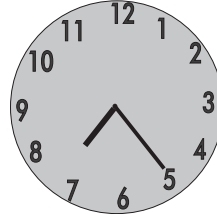
	An tAm	An tAm	An tAm	An tAm
Baile Átha Cliath (a.m.)				
Páras				
Perth				
Caireo				
Shanghai				
Tóiceo				
Moscó				

Léiríonn an chairt thíos áiteanna atá roinnt uaireanta an chloig ar gcúl ar am na hÉireann. Scríobh, sna boscaí thíos, an t-am áitiúil i gcomparáid le ham na hÉireann. Úsáid an córas 24 uair an chloig.

Líon na n-uaireanta ar gcúl ar am na hÉireann			
Montréal	5	Honolulu	10
Chicago	6	Meicsiceo	6
Los Angeles	8	Nua-Eabhrac	5

①

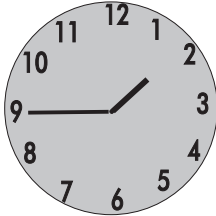
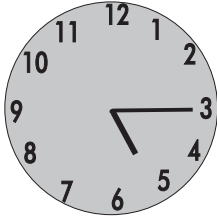
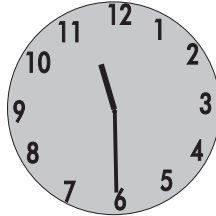
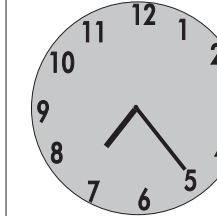
	An tAm	An tAm	An tAm	An tAm
Baile Átha Cliath (a.m.)				
Montréal				
Chicago				
Los Angeles				
Honolulu				
Meicsiceo				
Nua-Eabhrac				

Lúnasa 2008

D	L	M	C	D	A	S
					1	2
3	4	5	6	7	8	9
10	11	12	13	14	15	16
17	18	19	20	21	22	23
24	25	26	27	28	29	30
31						

Meán Fómhair 2008

D	L	M	C	D	A	S
	1	2	3	4	5	6
7	8	9	10	11	12	13
14	15	16	17	18	19	20
21	22	23	24	25	26	27
28	29	30				

① Líon na Máirteanna i Lúnasa 2008 :

② Líon na nAointe i Meán Fómhair 2008 :

Deireadh Fómhair 2008

D	L	M	C	D	A	S
			1	2	3	4
5	6	7	8	9	10	11
12	13	14	15	16	17	18
19	20	21	22	23	24	25
26	27	28	29	30	31	

Samhain 2008

D	L	M	C	D	A	S
						1
2	3	4	5	6	7	8
9	10	11	12	13	14	15
16	17	18	19	20	21	22
23	24	25	26	27	28	29
30						

③ Líon na nDomhnaí i nDeireadh Fómhair 2008 :

④ Líon na Satharn i Samhain 2008:

Deireadh Fómhair 2008

①

D	L	M	C	D	A	S
			1	2	3	4
5	6	7	8	9	10	11
12	13	14	15	16	17	18
19	20	21	22	23	24	25
26	27	28	29	30	31	

An dara Luan sa mhí, sin an

Deireadh Fómhair 2008.

②



Cén lá den tseachtain ar a dtiteann Oíche Shamhna?

③

Cén dáta é seachtain amháin roimh Oíche Shamhna?



④

Cé na míonna a bhfuil an líon céanna laethanta iontu is atá i nDeireadh Fómhair?

Nollaig 2008



D	L	M	C	D	A	S
	1	2	3	4	5	6
7	8	9	10	11	12	13
14	15	16	17	18	19	20
21	22	23	24	25	26	27
28	29	30	31			



①

Cuir ciorcal timpeall ar an dáta a bheidh ann 21 lá i ndiaidh 3 Nollaig. Bain úsáid as na patrúin uimhris.

②

Cuir líne trí na huimhreacha go léir ar an bhféilire nach bhfuil aon fhuílleach acu nuair a roinntear ar 7 iad.

③

Tá Deirdre 183 mí d'aois. Cén aois í?

Bliana Mí

④

Lá breithe Choilm é an chéad Mháirt i mí na Nollag.

Is é an a lá breithe.



Litrigh 'féilire'

Bí cúramach!

Baile Átha Cliath go Birmingham		
Uimhir na hEitilte	Ag imeacht	Ag teacht isteach
FR 660	07.00	07.55
FR 662	09.40	10.35
FR 664	13.10	14.05
FR 668	15.50	16.45

Baile Átha Cliath go Learpholl		
Uimhir na hEitilte	Ag imeacht	Ag teacht isteach
FR 442	07.10	07.55
FR 446	16.30	17.15
FR 448	17.50	18.35
FR 450	18.10	18.55

Baile Átha Cliath go dtí an Bhruiséil		
Uimhir na hEitilte	Ag imeacht	Ag teacht isteach
FR 40	06.55	09.25
FR 42	13.55	16.25
FR 44	17.50	20.20

① Cén fad a ghlacann sé eitilt

- (a) Ó Bhaile Átha Cliath go Birmingham?
- (b) Ó Bhaile Átha Cliath go Learpholl?
- (c) Ó Bhaile Átha Cliath go dtí an Bhruiséil?

Corcaigh go Londain		
Uimhir na hEitilte	Ag imeacht	Ag teacht isteach
FR 902	09.00	10.15

Baile Átha Cliath go Glaschú		
Uimhir na hEitilte	Ag imeacht	Ag teacht isteach
FR 772	07.00	07.45

Baile Átha Cliath go Páras		
Uimhir na hEitilte	Ag imeacht	Ag teacht isteach
FR 22	07.05	09.30

*

Glaschú go Londain		
Uimhir na hEitilte	Ag imeacht	Ag teacht isteach
FR 613	08.10	09.00

Baile Átha Cliath go Caerdydd (Cardiff)		
Uimhir na hEitilte	Ag imeacht	Ag teacht isteach
FR 880	11.00	11.55

- ① Cén fad a thógann sé eitilt
- (a) Ó Bhaile Átha Cliath go Páras?
- (b) Ó Bhaile Átha Cliath go Glaschú?
- (c) Ó Bhaile Átha Cliath go Caerdydd (Cardiff)?
- (d) Ó Chorcaigh go Londain?
- (e) Ó Ghlaschú go Londain?

* **Nótáil:**
Am áitiúil
Pháras

- ① Thaisteal tiománaí leoraí 648 ciliméadar idir 09.35 agus 14.05. Cén luas a bhí faoi, ina chiliméadair san uair?
- ② D'fhág teaghlach Caisleán an Bharraigh ar 11.20. Shroich siad Corcaigh ar 17.43. Chaith siad 1 uair 25 nóiméad ag ithe béile agus 7 nóiméad i ngaráiste. Cén fad ama a chaith siad ag taisteal?
- ③ D'fhág tiománaí Luimneach ar 10.48 agus shroich sé Baile Átha Cliath ar 14.07. Cén fad ama a chaith sé ag taisteal?
- ④ D'fhág bus Baile Átha Cliath ar 3.25 p.m. agus shroich sé Port Láirge ar 9.00 p.m. Cén fad ama a mhair an turas?
- ⑤ Seirbhís bus a thosaíonn ar 07.15 agus a ritheann gach 10 nóiméad ina dhiaidh sin. Cén t-am a d'fhág na chéad chúig bhus eile?
- ⑥ Bus atá ag taisteal ar mheánluas 60 ciliméadar san uair, cé mhéad ciliméadar a thaisteal sé idir 11.45 agus 13.30?
- ⑦ Bhí gluasteán ag taisteal ar 57 ciliméadar san uair. Cén fad a thaisteal sé in imeacht $2\frac{1}{2}$ uair.
- ⑧ Tosaíonn an scoil ar 9.15 a.m. agus críochnaíonn sí ar 3.00 p.m. Cé mhéad uair an chloig sa tseachtain a chaitheann na páistí ar scoil?
- ⑨ Cé mhéad ciliméadar a thiomáin fear ó 9.40 go dtí 12.10 agus é ag tiomáint ar 70 ciliméadar san uair?
- ⑩ Buachaill a éiríonn gach lá ar 7.20 a.m. agus a théann a luí gach oíche ar 8.45 p.m.
 - (a) Cé mhéad ama a chaitheann sé ina shuí?
 - (b) Cé mhéad ama a chaitheann sé ina luí?

Codáin Dheachúlacha (2)

Uimhreacha deachúlacha a Iolrú

Sampla:

$$\begin{array}{r} 4.25 \\ \times 23 \\ \hline 1275 \\ 8500 \\ \hline 97.75 \end{array}$$

Má tá digit amháin i ndiaidh an phointe deachúlaigh sa cheist caithfidh digit amháin a bheith i ndiaidh an phointe deachúlaigh sa fhreagra.

Má tá dhá dhigit i ndiaidh an phointe deachúlaigh sa cheist (.25 sa sampla thuas) caithfidh dhá dhigit a bheith ina dhiaidh sa fhreagra freisin (.75 sa sampla thuas).

Déan iad seo thíos anois.

- ① (a) 3.97×47
- (b) 4.56×49
- (c) 3.86×53
- (d) 8.79×84

Codán Deachúlach a iolrú faoi Chodán Deachúlach

Sampla:

$$\begin{array}{r} 4.25 \\ \times 0.23 \\ \hline 1275 \\ 8500 \\ \hline 0.9775 \end{array}$$

Bíodh an líon céanna digití i ndiaidh an phointe deachúlaigh sa fhreagra is atá i ndiaidh na bpointí deachúlacha sa cheist.

1

(a) $1.23 \times 0.46 =$

(b) $9.28 \times 0.78 =$

(c) $2.19 \times 0.92 =$

(d) $4.82 \times 0.72 =$

(e) $3.17 \times 0.45 =$

(f) $8.92 \times 0.53 =$

(g) $5.18 \times 0.34 =$

(h) $3.16 \times 0.82 =$

(i) $5.19 \times 0.67 =$

(j) $3.24 \times 0.29 =$

2

(a) $1.24 \times 2.9 =$

(b) $4.19 \times 6.7 =$

(c) $2.16 \times 8.2 =$

(d) $4.18 \times 3.4 =$

(e) $7.92 \times 5.3 =$

(f) $2.17 \times 4.5 =$

(g) $3.82 \times 7.2 =$

(h) $1.29 \times 9.2 =$

(i) $8.27 \times 8.7 =$

(j) $1.43 \times 4.6 =$

Uimhreacha deachúlacha a Roinnt

Nuair is uimhir dheachúlach atá le roinnt.

Sampla: $20.746 \div 82$

$$\begin{array}{r}
 00.253 \\
 82 \overline{)20.746} \\
 \underline{164} \\
 434 \\
 \underline{410} \\
 246 \\
 \underline{246} \\
 0
 \end{array}$$



An Roinnteoir

An Inroinnt

An Líon

An Fuílleach

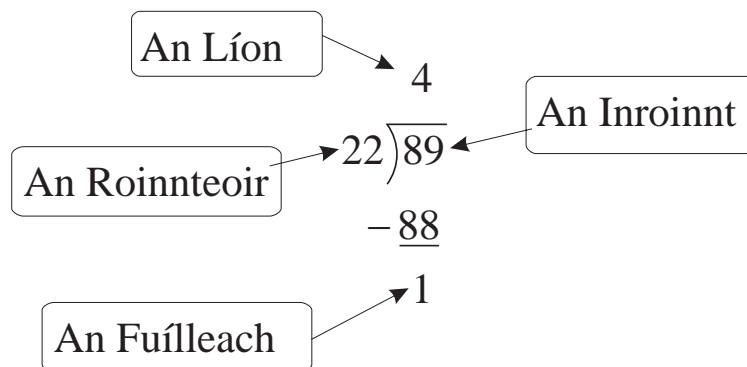

Sampla: $8.4 \div 21$

$$\begin{array}{r}
 0.4 \\
 21 \overline{) 8.4} \\
 \underline{-8 \ 4} \\
 0
 \end{array}$$

Freagra: 0.4

Déan iad seo ar an mbealach céanna leis na samplaí ar an leathanach roimhe seo.

- ① (a) $59.5 \div 5$
 (b) $49.8 \div 3$
 (c) $77.4 \div 6$
 (d) $39.96 \div 9$

Nuair is codán deachúlach é an roinnteoir.

Caithfimid ‘fáil réidh’ leis an bpointe deachúlach sa roinnteoir.

Sampla 1: $59.65 \div 0.5$

Iolraigh an dá thaobh faoi 10

$$= 596.5 \div 5$$

$$\begin{array}{r} 5 \overline{)596.5} \\ \underline{119.3} \end{array}$$

Freagra: 119.3

Déan iad seo thíos anois.

- ② (a) $4.28 \div 1.07$ (b) $23.808 \div 0.62$
 (c) $15.224 \div 0.44$ (d) $220.78 \div 16.6$
 (e) $27.072 \div 0.36$ (f) $38.005 \div 0.55$

Sampla 2: $16.254 \div 6.3$

Iolraigh an dá thaobh faoi 10

$$= 162.54 \div 63$$

An Líon

An Roinnteoir

An Inroinnt

$$\begin{array}{r}
 \overline{) 162.54} \\
 \underline{126} \\
 36 \\
 \underline{31} \\
 5 4 \\
 \underline{5} 4 \\
 0
 \end{array}$$

Freagra: 2.58

- (a) $35.96 \div 2.9$
- (b) $61.1 \div 4.7$
- (c) $227.84 \div 3.2$
- (d) $113.76 \div 4.8$

Cruth agus Spás in 2-T

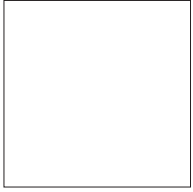

cearnóg

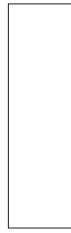

dronuilleog

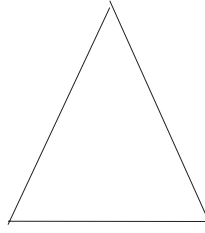

triantán

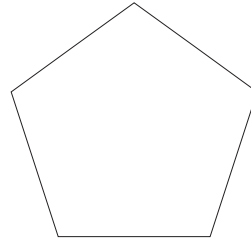

peinteagán

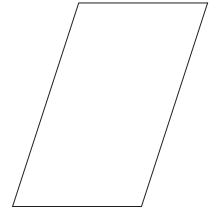

comhthreomharán

①

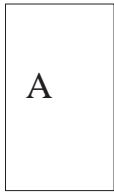

A



B

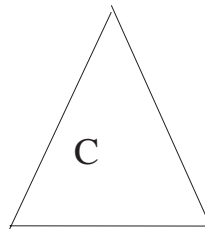

C

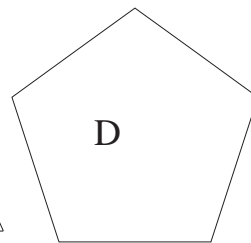

D

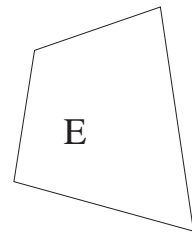

E

Liostaigh na dronuilleoga thuas. _____

Ceathairshleasán a thugtar ar chruth ar bith a bhfuil ceithre shlios air.

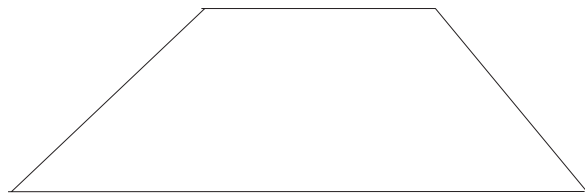
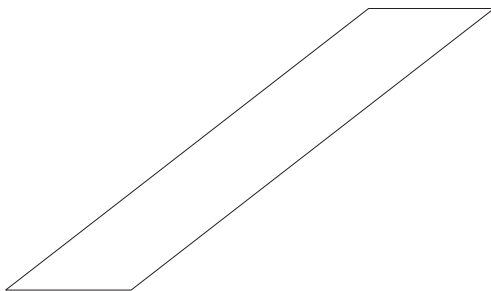
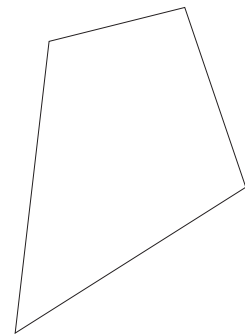
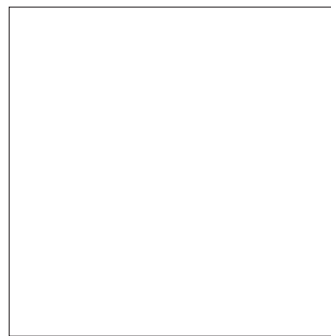
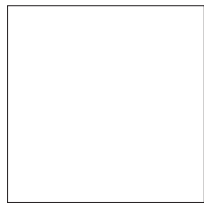
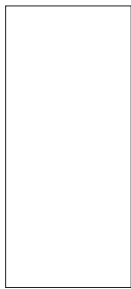

Ceathairshleasáin iad cearnóga, dronuilleoga, comhthreomharáin, etc.

Polagáin

Cruthanna iad polagáin a bhfuil trí uillinn nó níos mó orthu.

Focal Gréigise ba ea ‘polagán’ a chiallaigh ‘il-uilleach’

Is polagáin iad seo thíos.

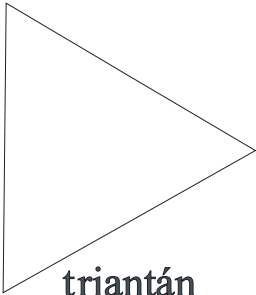

triantán

shlios

uillinn

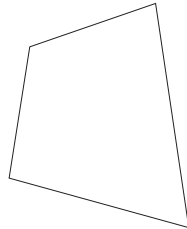

ceathairshleasán

shlios

uillinn

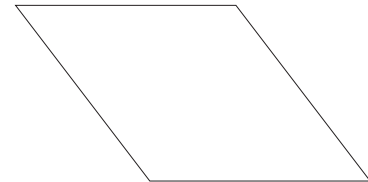

comhthreomharán

shlios

uillinn



dronuilleog

shlios

uillinn

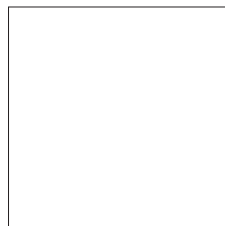

cearnóg

shlios

uillinn

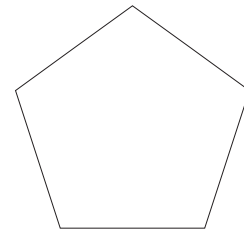

peinteagán

shlios

uillinn

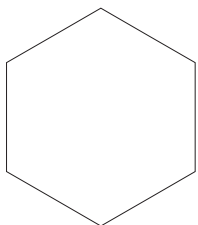

heicseagán

shlios

uillinn

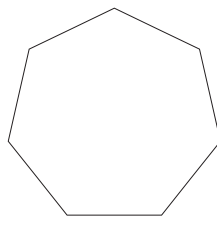

heipteagán

slios

n-uillinn

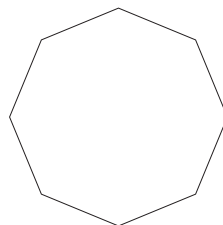

ochtagán

slios

n-uillinn

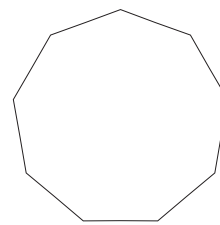

nónagán

slios

n-uillinn

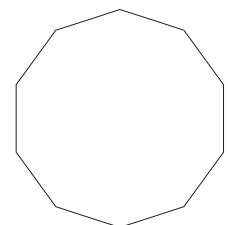



deacagán

slios

n-uillinn

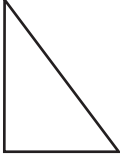
Líon na bearnaí sa tábla thíos

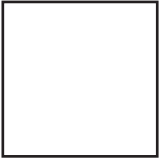
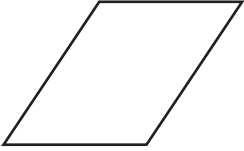
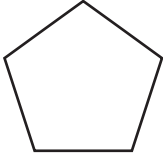
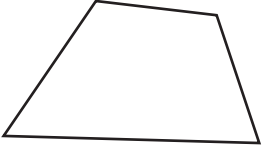
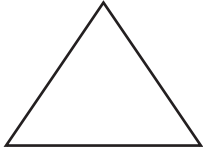
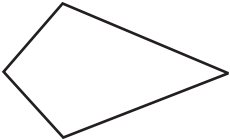
	Airíonna Cruthanna		
	4 shlios air	Dronuillinn amháin nó níos mó	Dhá péire sleasa comhthreomhara
	<input checked="" type="checkbox"/>	<input checked="" type="checkbox"/>	<input checked="" type="checkbox"/>
	<input type="checkbox"/>	<input type="checkbox"/>	<input type="checkbox"/>
	<input type="checkbox"/>	<input type="checkbox"/>	<input type="checkbox"/>
	<input type="checkbox"/>	<input type="checkbox"/>	<input type="checkbox"/>
	<input type="checkbox"/>	<input type="checkbox"/>	<input type="checkbox"/>
	<input type="checkbox"/>	<input type="checkbox"/>	<input type="checkbox"/>
	<input type="checkbox"/>	<input type="checkbox"/>	<input type="checkbox"/>
	<input type="checkbox"/>	<input type="checkbox"/>	<input type="checkbox"/>

Cearnóg a Dhéanamh

Is féidir cearnóg a roinnt ina cearnóga beaga. Is féidir na cearnóga beaga sin a roinnt ina gcearnóga níos lú fós.

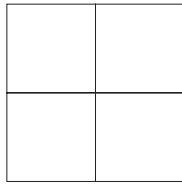
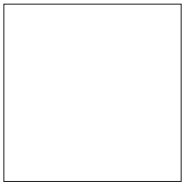

cearnóg roinnte
ina ceithre cearnóg

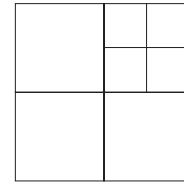

cearnóg roinnte
ina seacht gcearnóg

Roinn gach cearnóg faoi mar atá luaite thíos.

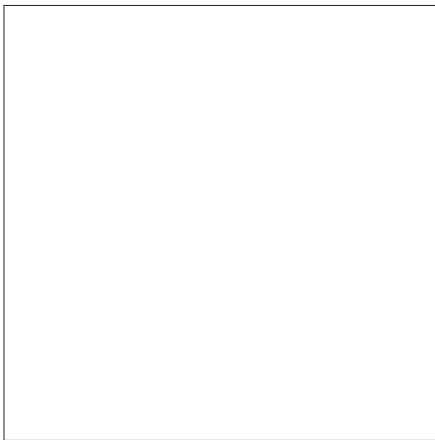

10 gcearnóg

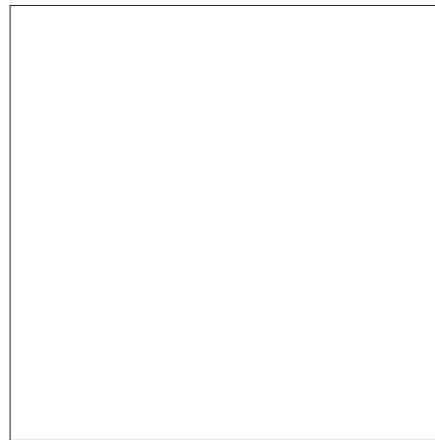

13 cearnóg

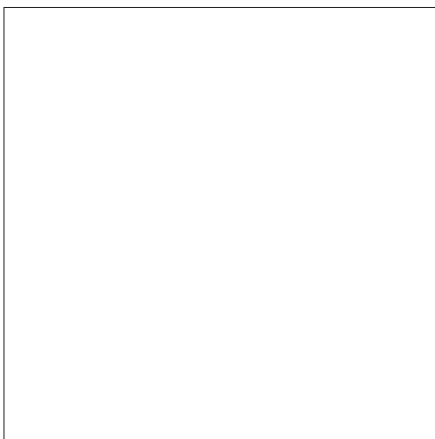

19 gcearnóg

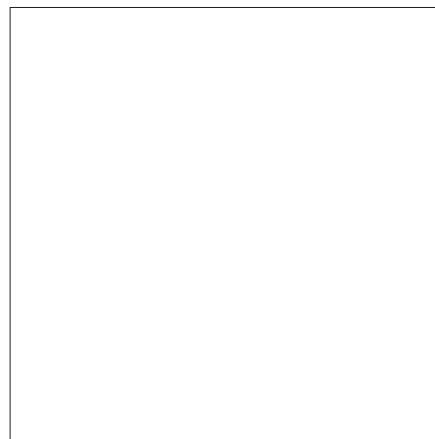

22 cearnóg

- ① An féidir leat cearnóg a roinnt ar an mbealach sin thuas ionas go mbeidh sé cearnóg inti? 8 gcearnóg? 9 gcearnóg? Aon cearnóg déag? Dhá cearnóg déag? Ceithre cearnóg déag? Cúig cearnóg déag?
- ② An bhfuil patrún ag baint le líon na gcearnóg is féidir a dhéanamh?

Triantáin

Trí chineál triantán atá anseo thíos.

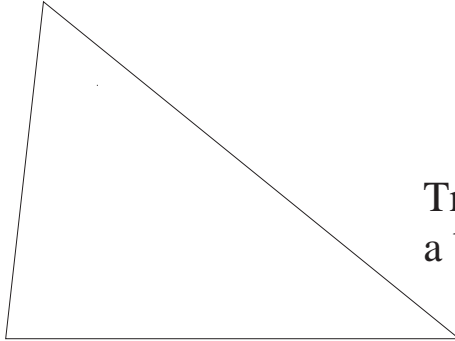

Triantán Scailéanach

Trí shlios neamhchothroma a bhíonn ar an triantán scailéanach.

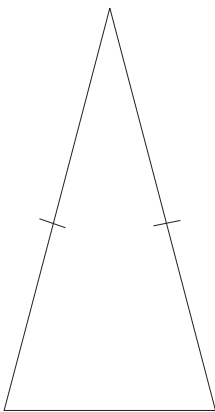

Triantán Comhchosach

Dhá shlios chothroma a bhíonn ar an triantán comhchosach.

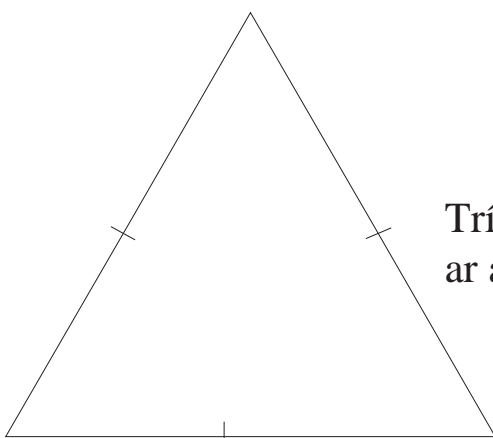

Triantán Comhshleasach

Trí shlios chothroma a bhíonn ar an triantán comhshleasach.

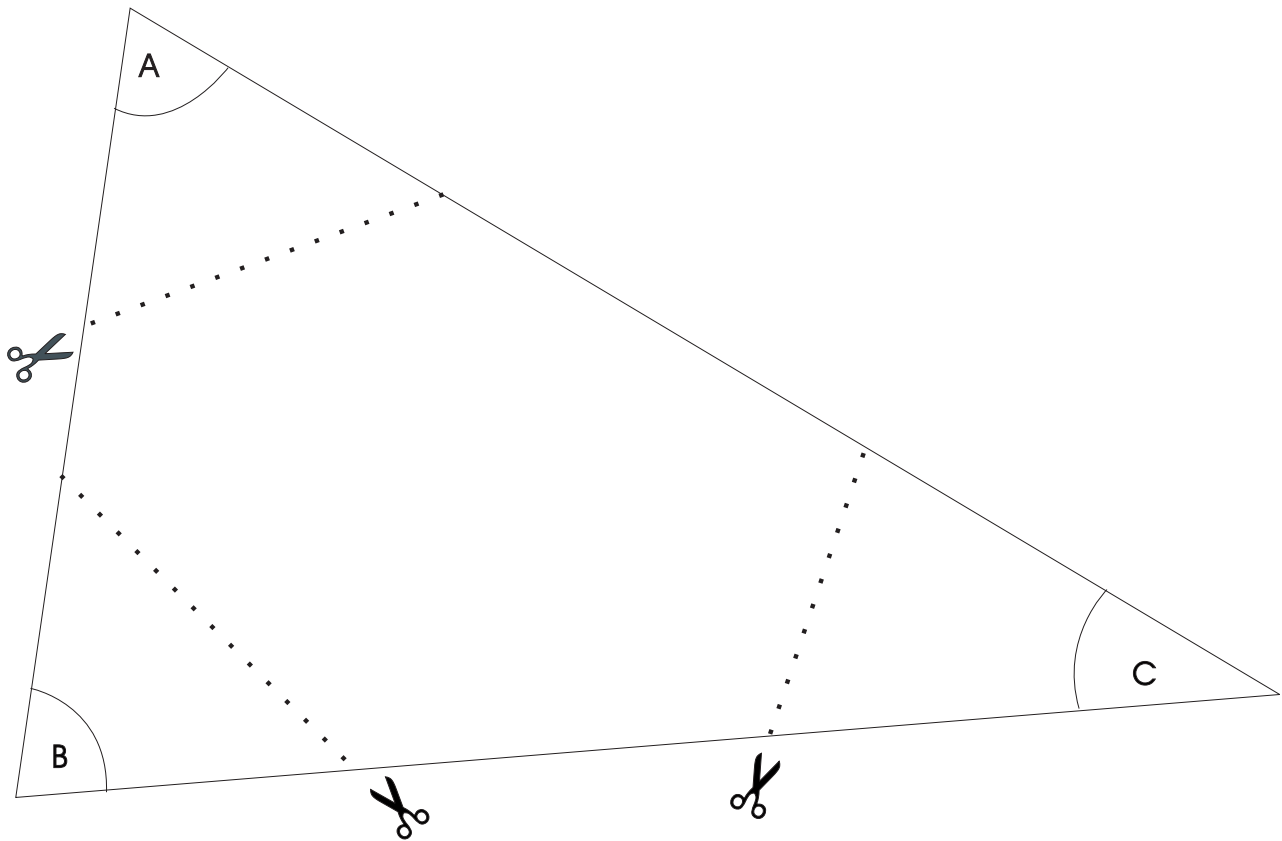

Déan (rianaigh) cóip bheacht den léaráid thuas.

Gearr amach na trí uillinn feadh na línte briste.

Leag amach na gearrthóga mar atá thíos.

Is é 180° suim na dtrí uillinn, sin líne dhíreach.

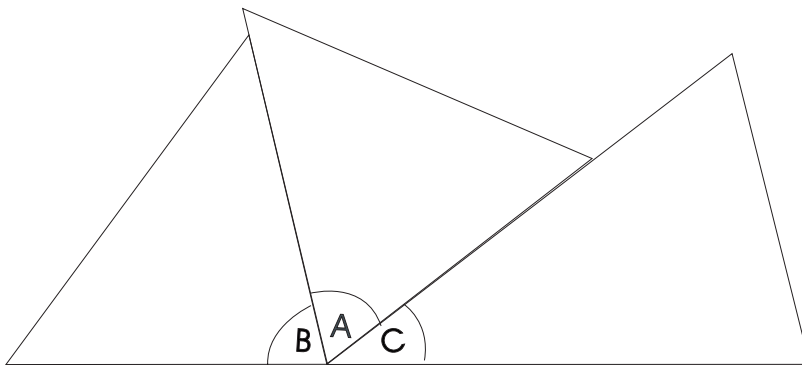

Ríomh méid na n-uillinneacha **a** – **e**.

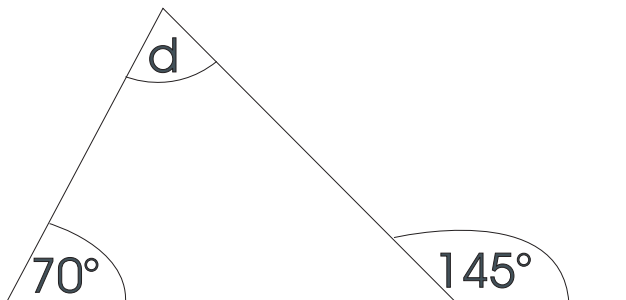
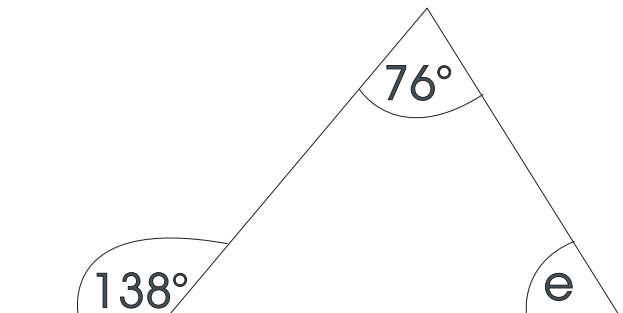
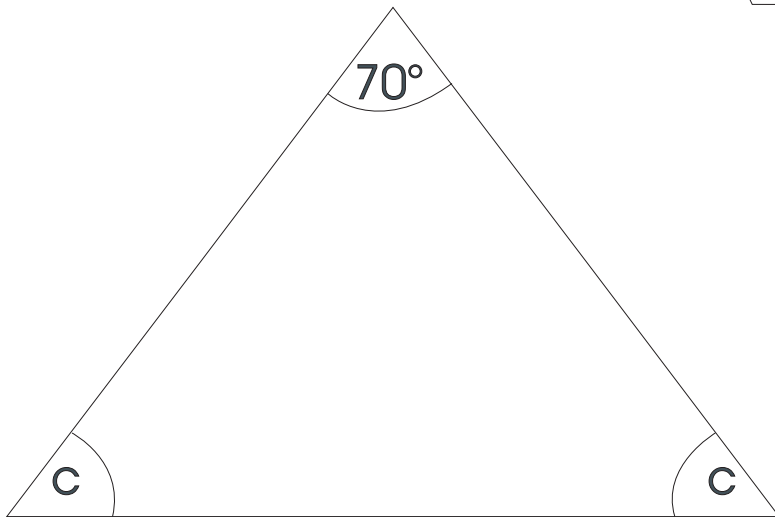
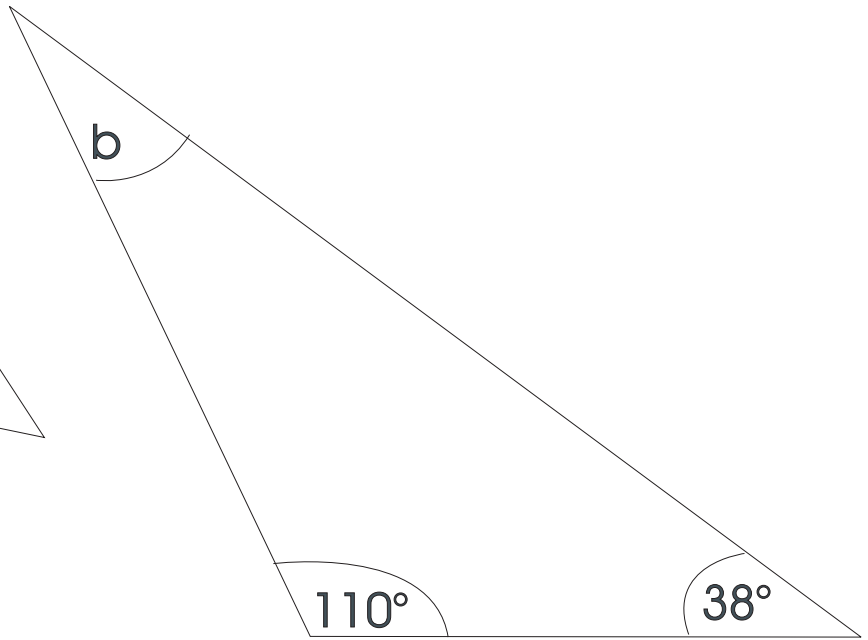
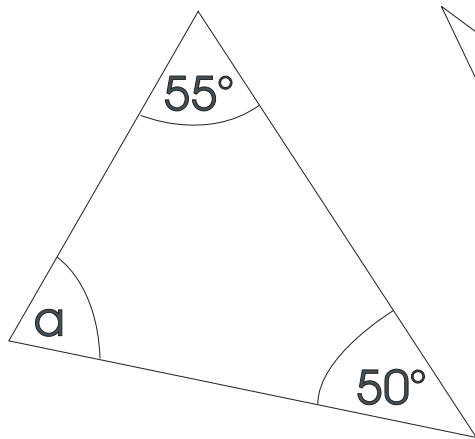

Ceangail na poncanna agus déan na cruthanna seo a leanas.

peinteagán

heicseagán

heipteagán

ochtagán

nónagán

deacagán

Scríobh ainm gach crutha laistigh den chruth.



Nuair is **Polagán Rialta** é bíonn an fad céanna sna sleasa uile.

Polagán a dhéanamh.

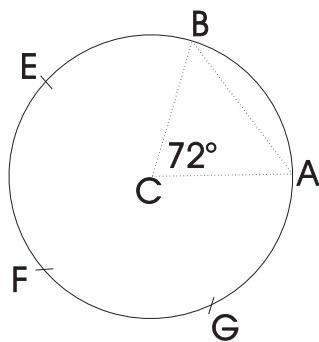
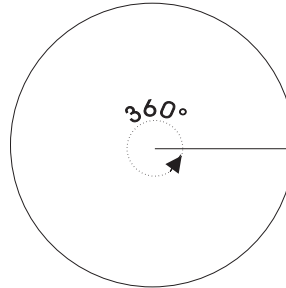
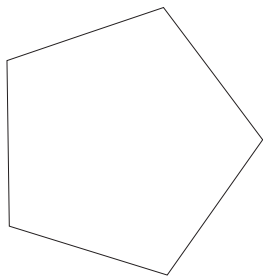

Tarraing ciorcal le do chompás. Bíodh méid an chiorcail in oiriúint do mhéid an pholagáin atá tú ag iarraidh a dhéanamh.

Roinn 360° ar líon na sleasa a bheidh sa pholagán.

e.g. peinteagán: $360^\circ \div 5 = 72^\circ$

Úsáid d'uillinntomhas agus tarraing an uillinn ACB

Úsáid an compás. Bíodh B ina lárphointe agat, agus AB ina gha, agus marcáil E ar imlíne an chiorcail.

Marcáil F agus G ar na mbealach céanna.

Ceangail A, B, E, F agus G le chéile leis an rialóir.

Rachaidh an cruth seo isteach san imlíne sin.

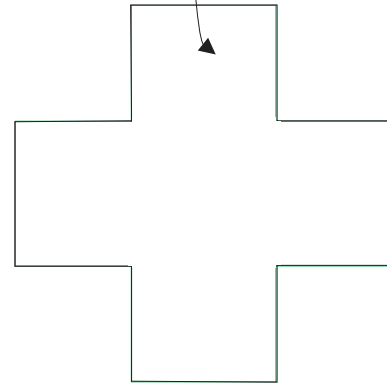
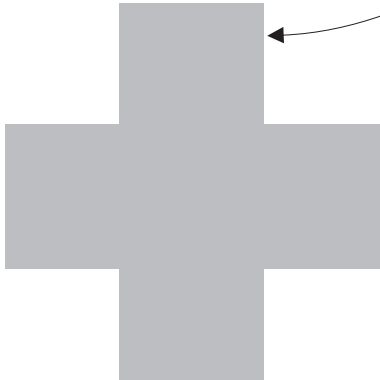

Cé mhéad bealach éagsúil a luífidh an cruth seo anuas go cruinn ar a imlíne, gan é a iompú droim ar ais? Breathnaímis na bealaí. Má chuirimid réiltín ar an gcruth cabhróidh sé linn na suímh éagsúla a aithint.

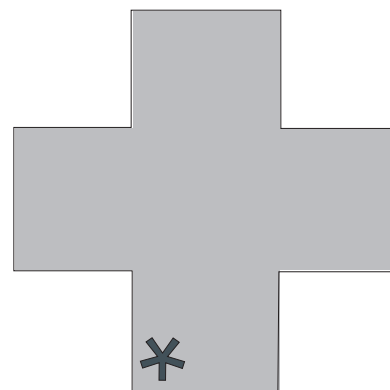
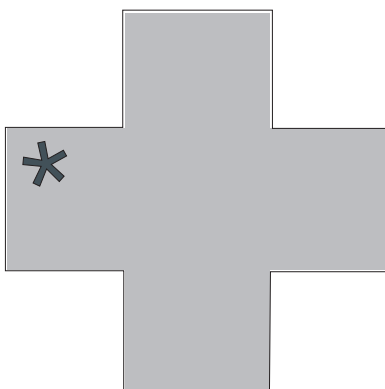
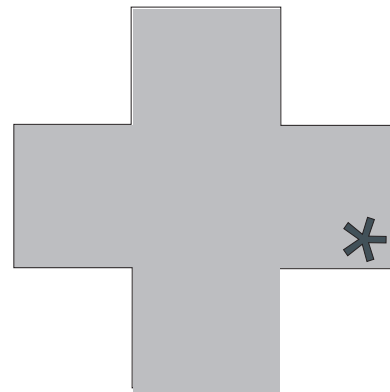
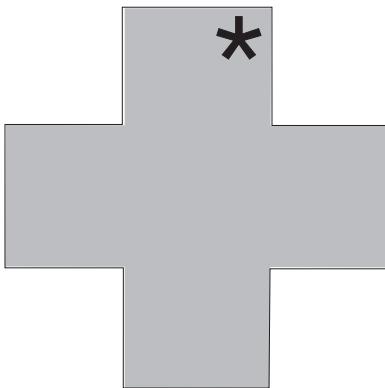

Cé mhéad bealach éagsúil a luífidh gach cruth díobh seo a leanas anuas ar a imlíne féin go cruinn, gan é a iompú droim ar ais?
 Féach ar an leathanach roimhe seo más mian leat.

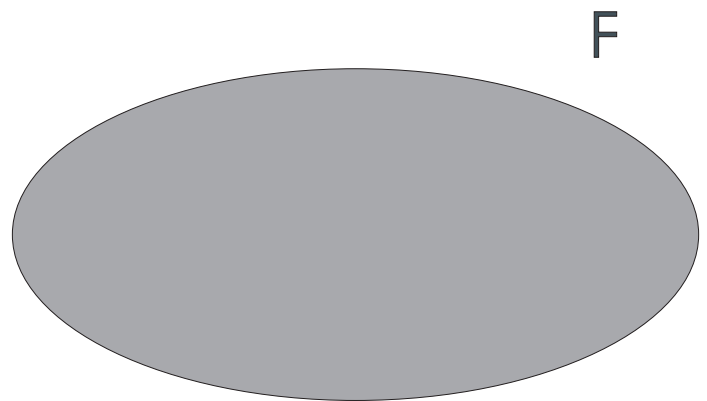
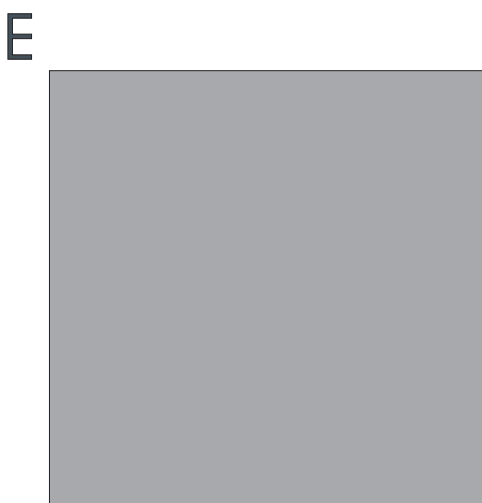
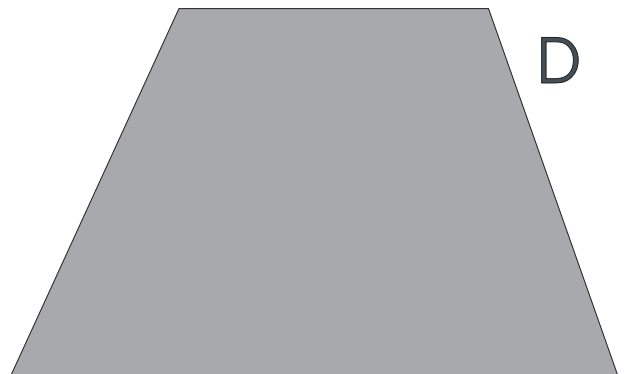
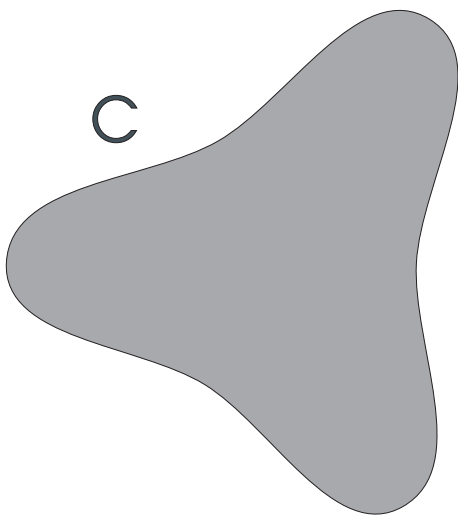
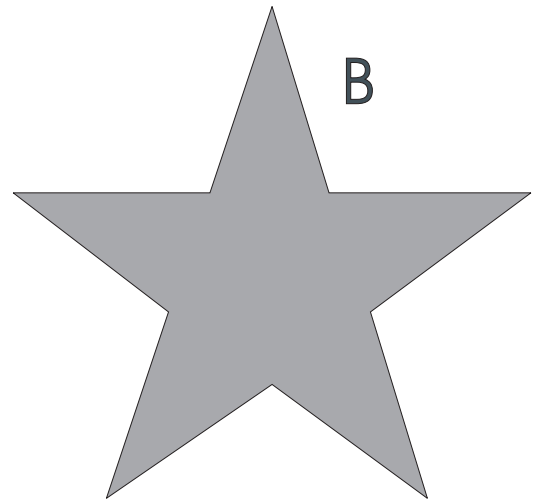
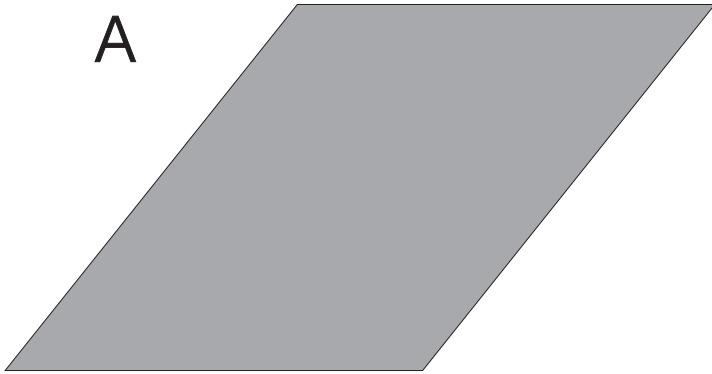

An Ciorcal

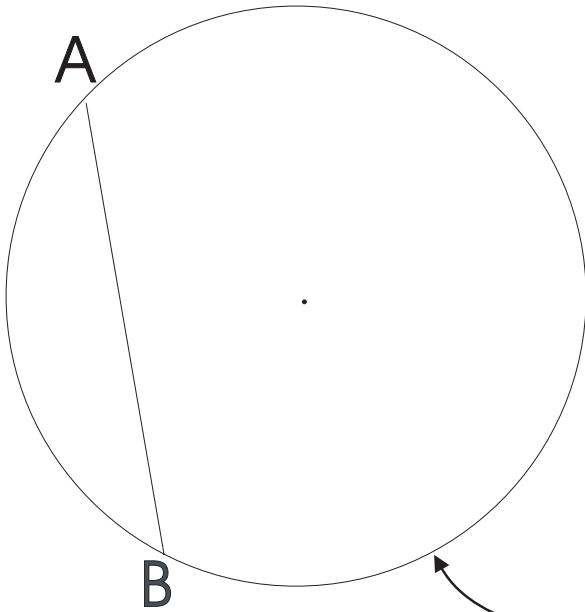

An **lárphointe** a thugtar ar lár ciorcail.

An **imlíne** a thugtar ar an líne chuar timpeall ar chiorcal.

Corda a thugtar ar an líne AB thuas.

Trastomhas a thugtar ar chorda tríd an lárphointe. Sin an corda is faide sa chiorcal.

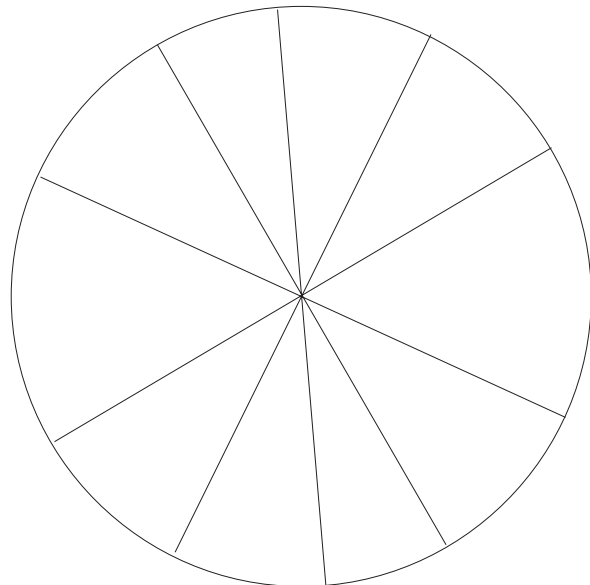

Na trastomhais uile i gchiorcal, bíonn an fad céanna iontu.

1

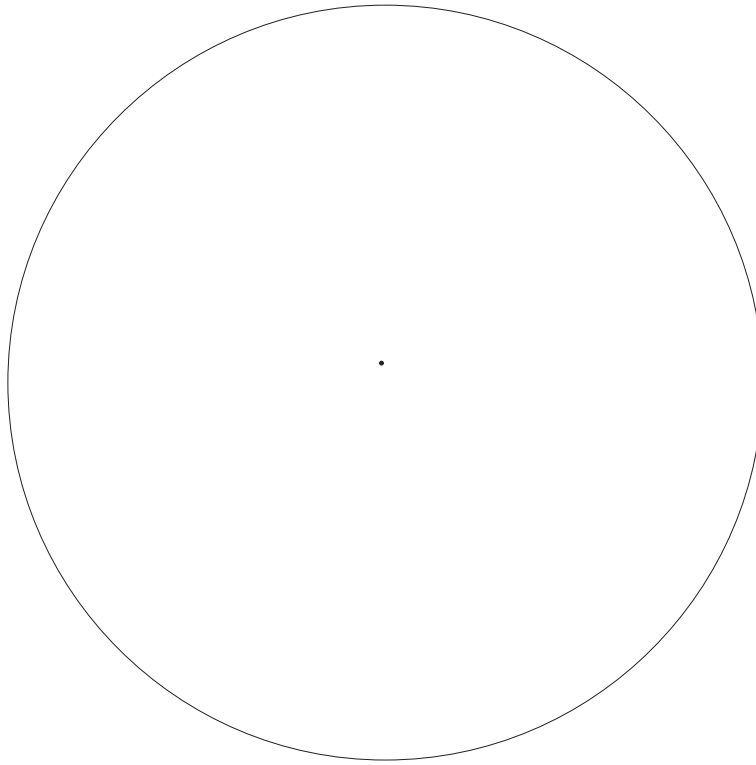

Tarraing 6 thrastomhas i dtreonna éagsúla.
(Cuimhnigh go dtéann an trastomhas tríd an lárphointe.)

Tomhais iad. Tá siad uile cm ar fad.

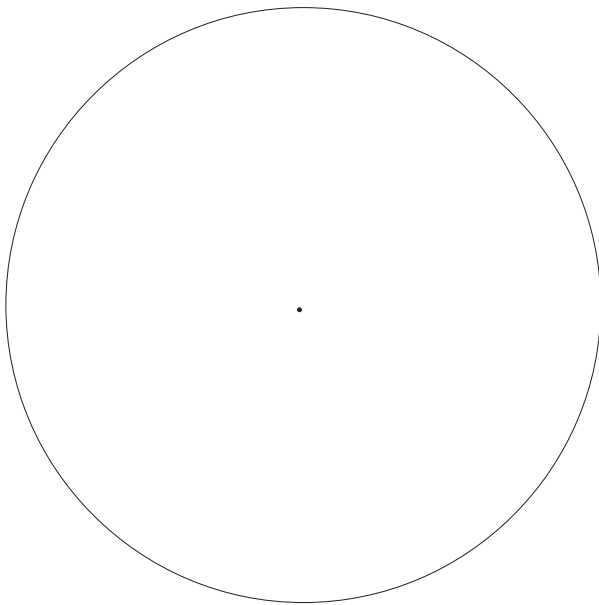

Tarraing 6 chorda in aon treo ar bith.
(**Ná cuir** tríd an lárphointe iad.)

Tomhais iad.

Tá an fad céanna iontu go léir.

Tá siad ar fhaid éagsúla.

Cuir tic ✓ sa bhosca ceart.

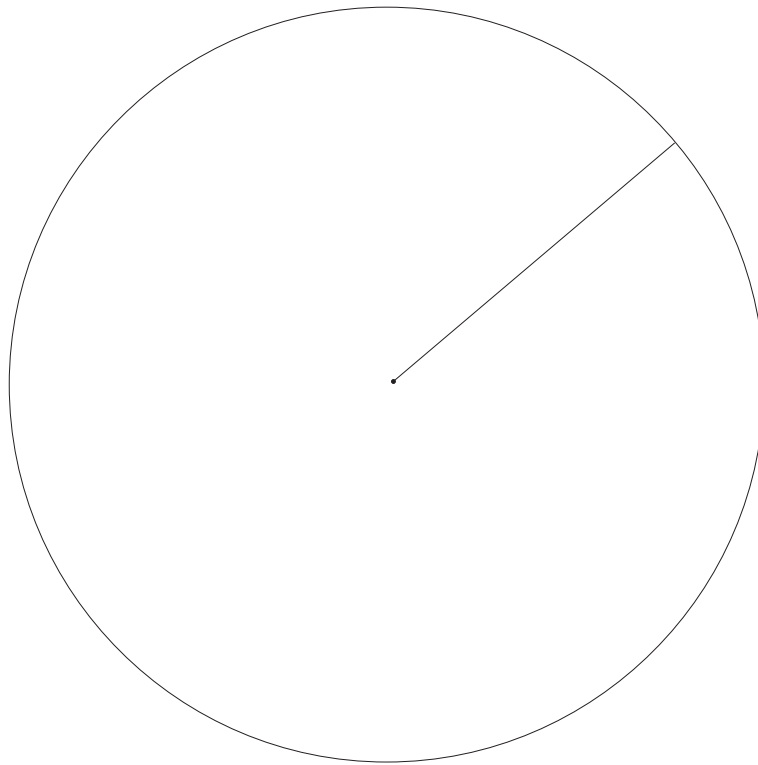

Ga a thugtar ar líne ón lárphointe go dtí an imlíne.

Ga = $\frac{1}{2}$ an trastomhais.

An trastomhas = ga agus é iolraithe faoi 2.

① Ga ciorcail = 8 cm.

Faigh trastomhas an chiorcail. cm

② Trastomhas ciorcail = 9 cm.

Faigh ga an chiorcail. cm

Ná
Dearmad

‘Gathanna’ an
t-iolra ar ‘ga’

Críochnaigh an tábla thíos

①	Trastomhas	25 cm		42 cm		30 cm	1 m
	Ga		2.5 cm		15½ cm		

② Tarraing trí chiorcal le do chompás a mbeidh an lárphointe céanna acu. Fad na ngathanna: 3 cm, 3.5 cm, 4 cm. Dathaigh an dearadh.

③ Tarraing an dearadh seo thíos le do chompás.

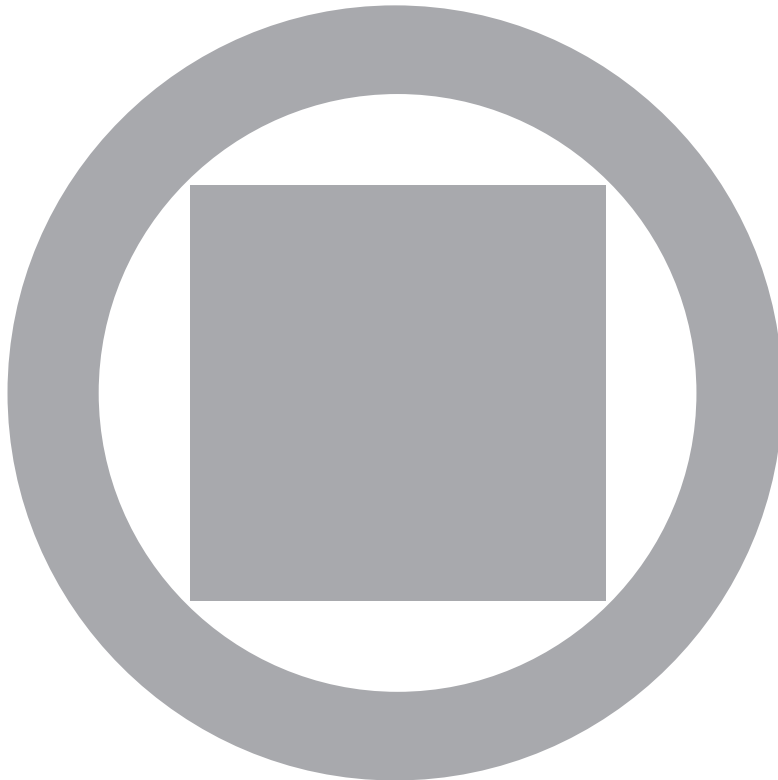

Bíonn uillinn 90° i gceathrú ciorcail.

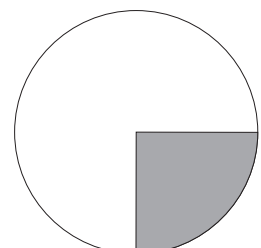
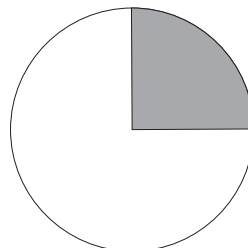
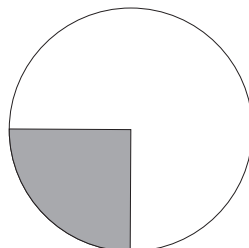

Tarraing na dearáí seo le do chompás.
Féach leis an lárphointe a aimsiú gach uair.

①

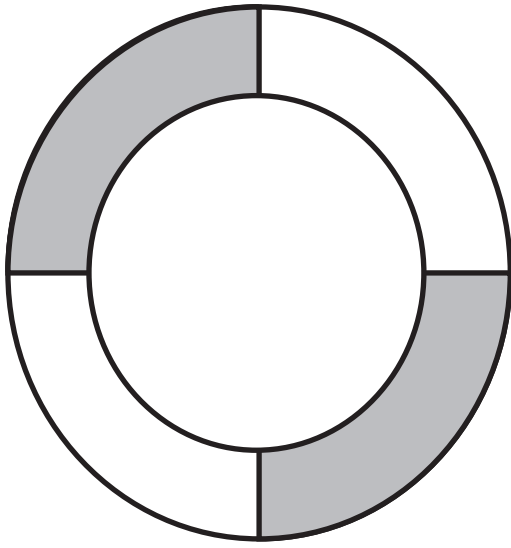

②

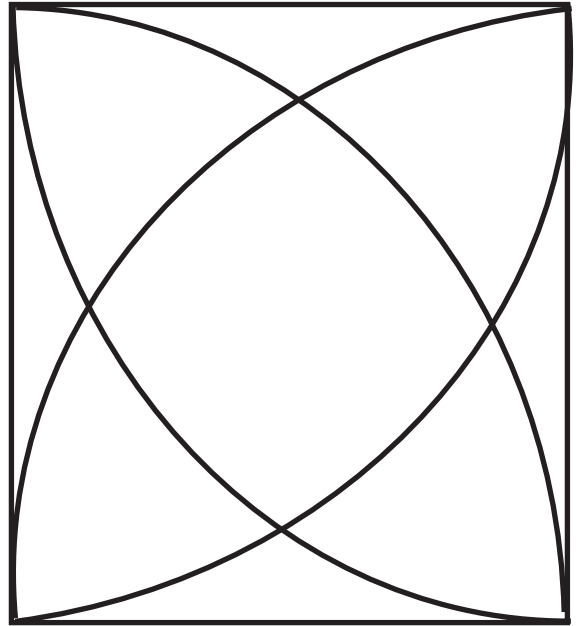

③

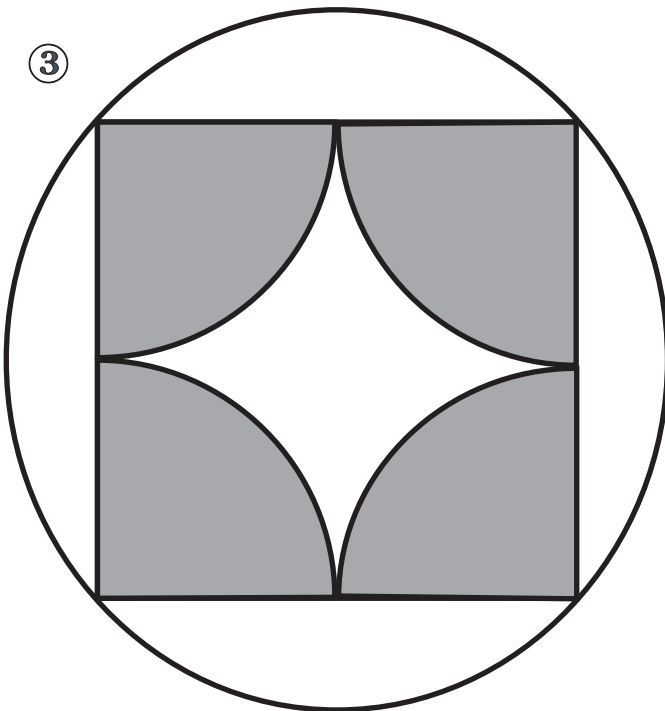

Bíonn an lárphointe
céanna ag ciorcail
chomhlárnacha.

- ① Tarraing na dearáí thíos. Tosaigh leis an gciorcal lasmuigh i ngach cás.

Bunaithe ar heicseagáin atá siad ar fad.

Bealach tapa le heicseagán a tharraingt: tarraing ciorcal agus marcáil fad an gha ar an imlíne ansin chun sé phointe an heicseagáin a mharcáil.

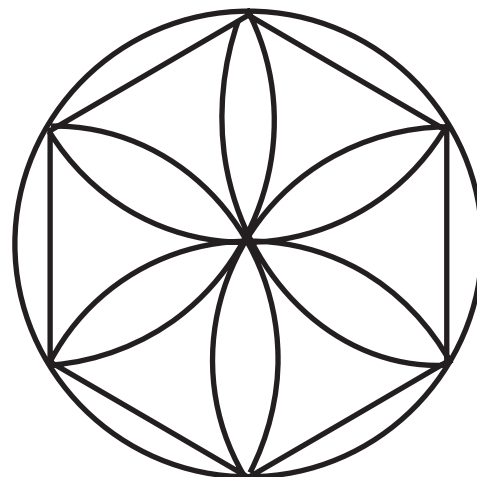
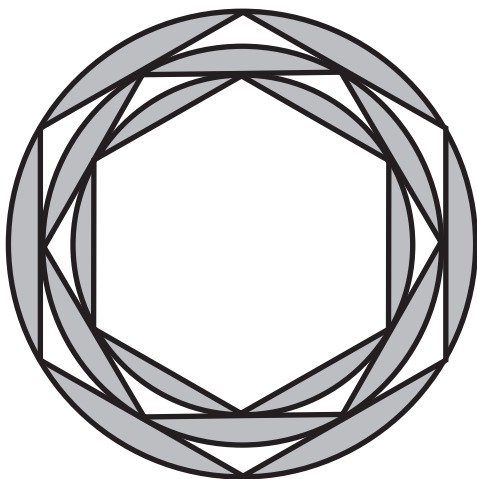
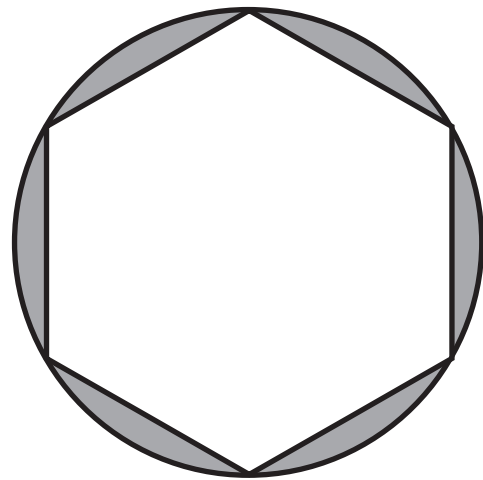
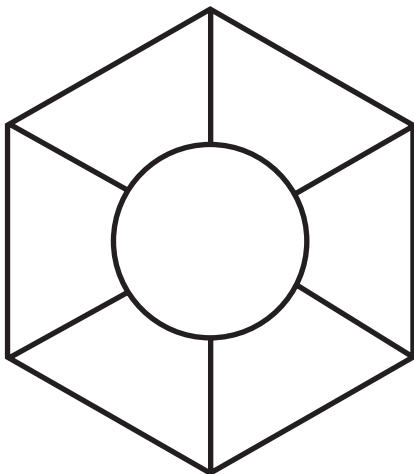
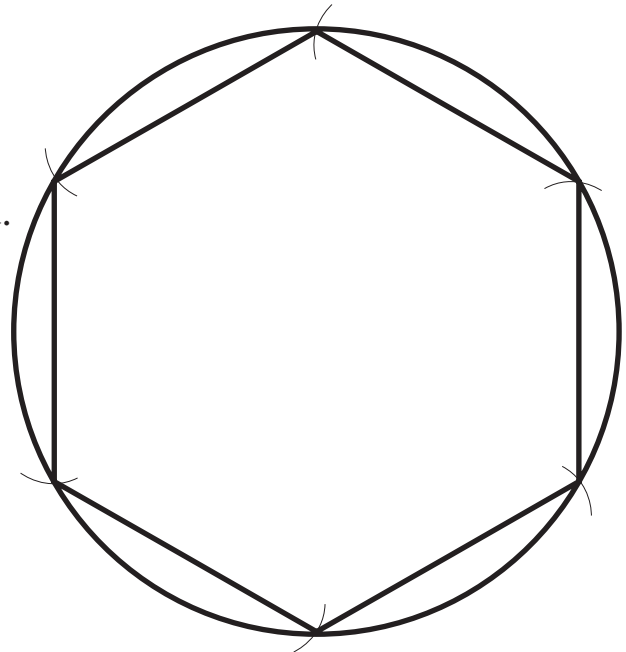

①

Ga an chiorcail seo = cm

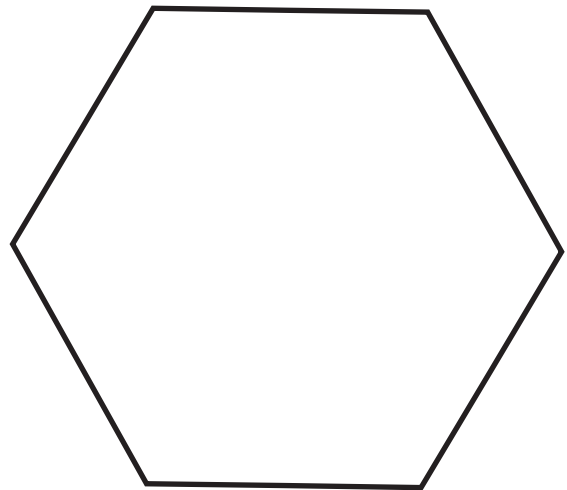
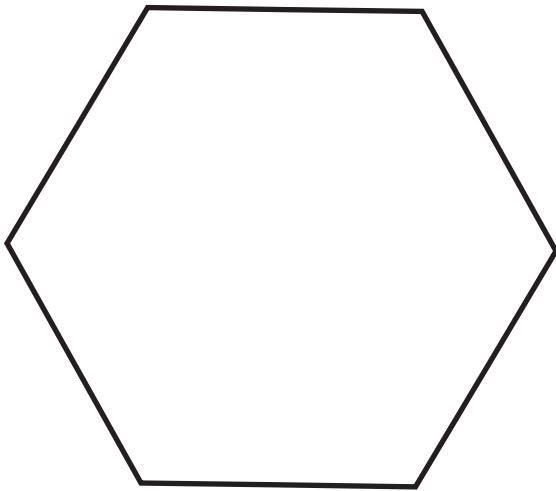
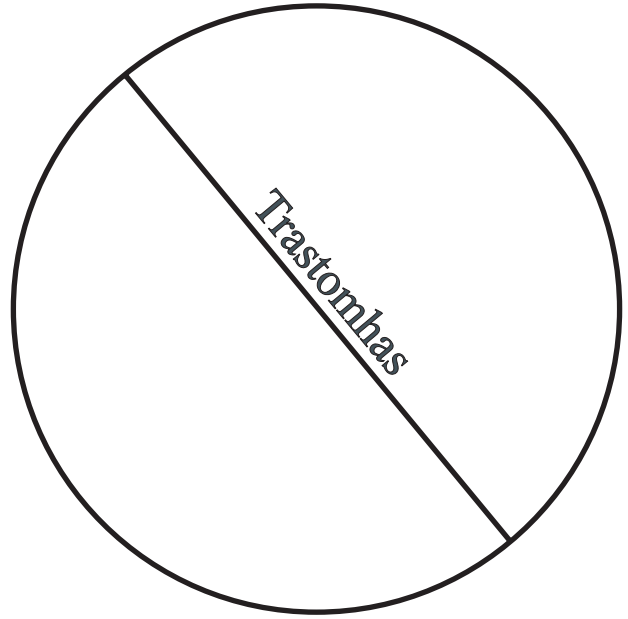

② Tarraing líne cheartingearach agus líne chothrománach ar an heicseagán seo agus déan 4 cheathairshleasán.

③ Tarraing líne cheartingearach agus líne chothrománach ar an heicseagán seo agus déan 2 thriantán agus 2 cheathairshleasán.

Scála

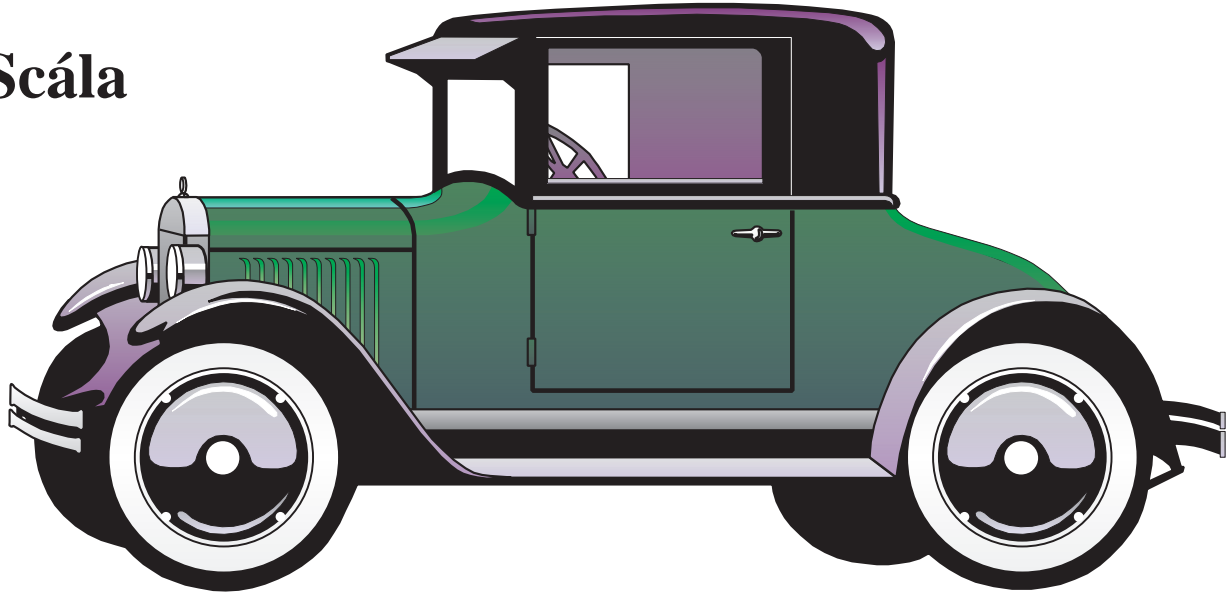

Diarmaid a rinne an gluaisteán beag seo - mionsamhail.
Tá dearadh a ghluaisteáin bunaithe ar an ngluaisteán mór thuas.

Tá mionsamhail Dhiarmada 40 cm ar fad.
Tá an gluaisteán mór 400 cm ar fad.

Deirimid go bhfuil fad an ghluaisteáin mhóir agus fad na mionsamhla sa chóimheas 400 le 40.

400 : 40 a scríobhaimid.

10 : 1 an fhoirm is simplí agus an cóimheas sin á scríobh.

Is é sin, tá an gluaisteán mór deich n-uaire níos faide ná an mhionsamhail.

- ① 1 cm le 8 m scála na línte anseo thíos.
Faigh an fad atá á léiriú ag gach líne díobh, ina mhéadair.

A _____

B _____

C _____

D _____

E _____

① Tarraing línte sa scála 1 cm le 6 m chun na faid thíos a léiriú.

18 m, 9 m, 30 m, 21 m.

② Tarraingíodh an plean tí thíos sa scála 1 cm le 0.8 m.

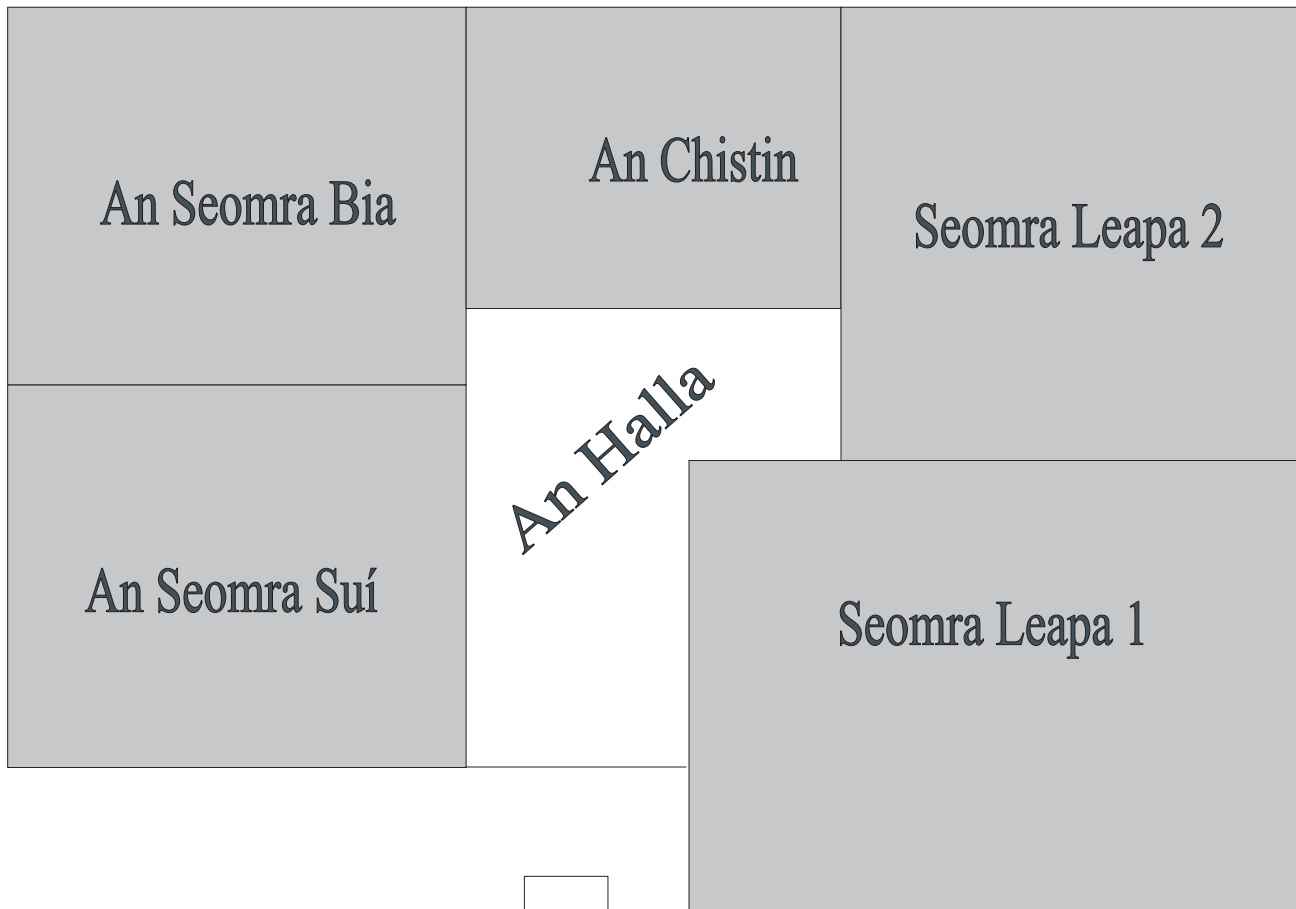

(a) Fad na Cistine =

 m

(b) Fad Sheomra Leapa 1 =

 m

(c) Fad an tSeomra Suí =

 m

(d) Fad an Halla =

 m

(e) Fad Sheomra Leapa 2 =

 m

Ó Thuaidh



Scála 1 cm : 5 m

Baineann ceisteanna 1 - 6 leis an bplean ar Leathanach 17-3.

① Cén t-ainm a thugtar ar an tsráid?

② Cén leithead atá sa tsráid?

③ Cén fad atá sa tsráid, ina mhéadair?

④ Cé chomh fada ó Oifig an Phoist is atá an Chógaslann?

⑤ Ríomh achar shiopa an bhúistéara ina mhéadair chearnaithe (m^2).

⑥ Cé mhéad teach atá ar an tsráid?

⑦ Tomhais fad agus leithead do sheomra leapa ina méadair, go dtí an méadar is gaire.

Tarraing plean den seomra sa scála 1 : 100.

⑧ Tomhais do leaba. Tarraing do leaba ar an bplean sa scála céanna.

Clós Súgartha

① Plean den chlós súgartha é seo.

Sa scála 1 cm : 4 m a tarraingíodh é

Faigh fíorthoisí an chlóis.

Cén t-achar atá sa chlós?

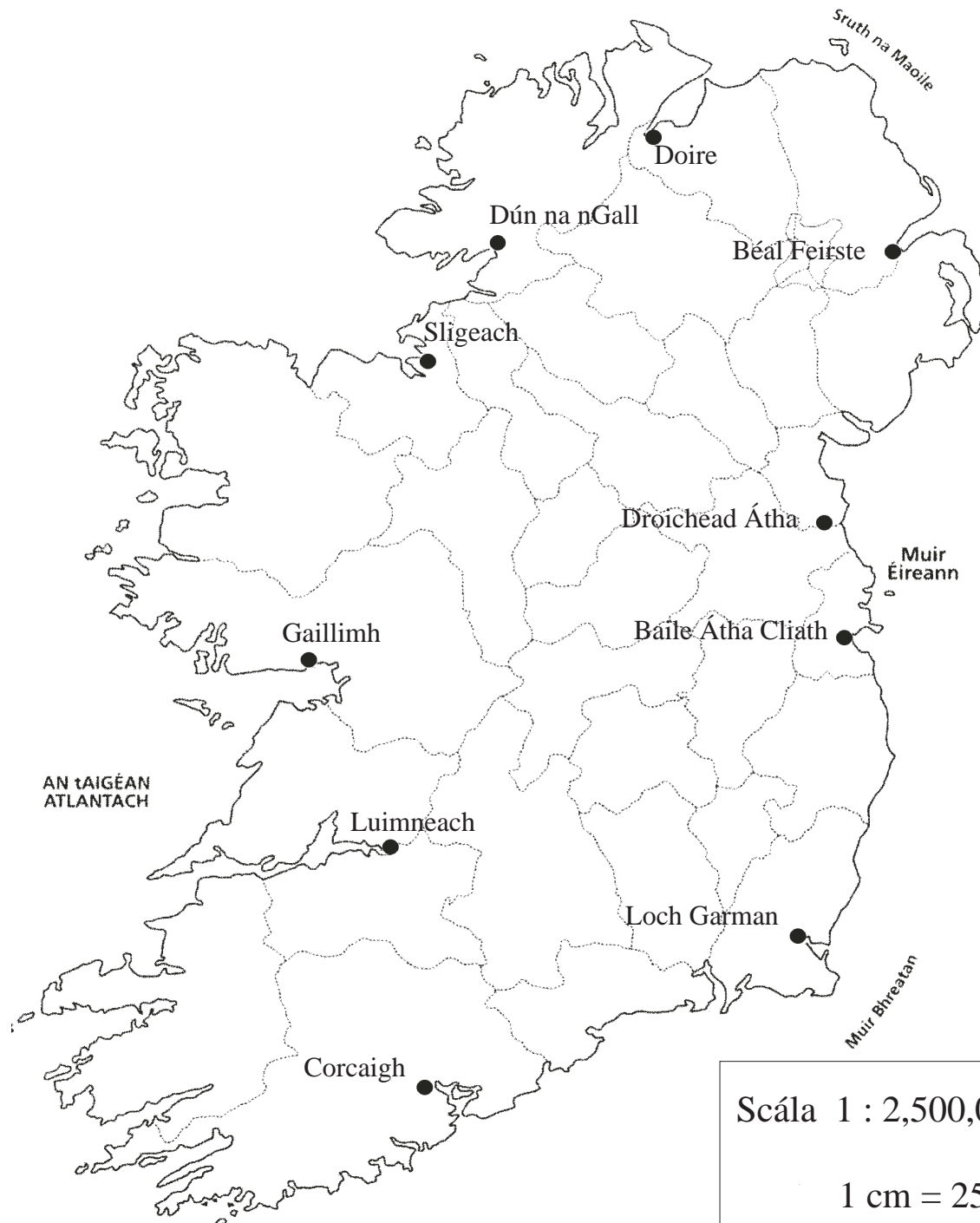

Faigh an fad ina chiliméadair:

- (a) Ó Bhaile Átha Cliath go Gaillimh km
- (b) Ó Chorcaigh go Luimneach km
- (c) Ó Loch Garman go Sligeach km
- (d) Ó Dhroichead Átha go Dún na nGall km

Nótáil:
 Bheadh an t-aistear níos faide ar na bóithre féin - ní línte díreacha iad!

Graif agus Cairteacha

Líon na nGluaisteán a Díoladh

Garáiste Uí Chinnéide

Eanáir 2006

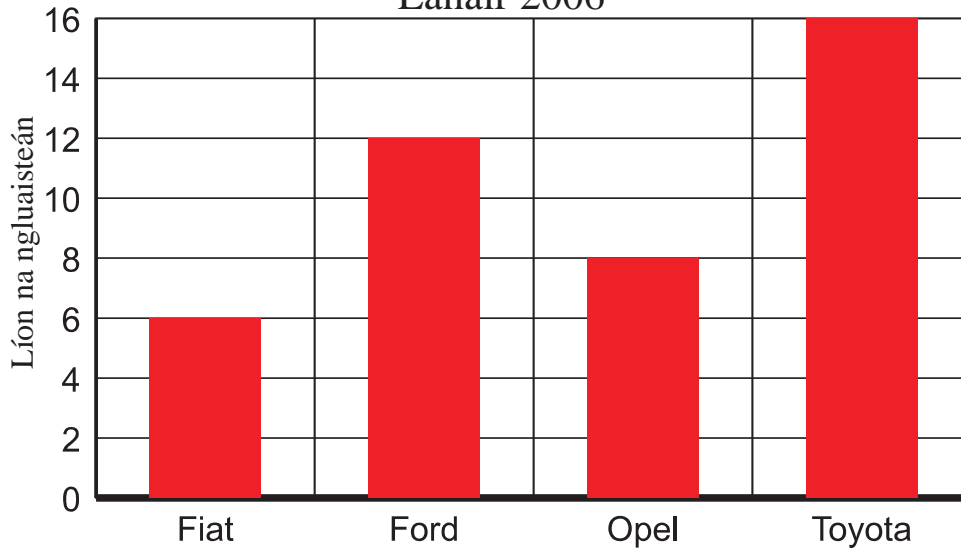

① Cé mhéad gluaisteán Ford a díoladh?

② Cé mhéad gluaisteán Opel a díoladh de bhreis ar ghluaisteáin Fiat?

③ Cén cineál gluaisteáin is mó a cheannaíonn daoine?

④ Cén cineál gluaisteáin is lú a cheannaíonn daoine?

⑤ Cé mhéad gluaisteán san iomlán a díoladh an mhí sin?

Is féidir an t-eolas ar Leathanach 18.1 a léiriú ar bharra-chairt **cheartingearach** nó ar bharra-chairt **chothrománach**.

Líon na nGluaisteán a Díoladh

Garáiste Uí Chinnéide
Eanáir 2006

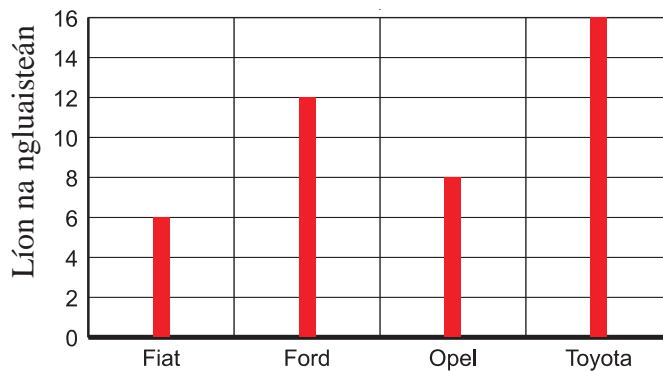

Barra-chairt Líneach Cheartingearach

Líon na nGluaisteán a Díoladh

Garáiste Uí Chinnéide
Eanáir 2006

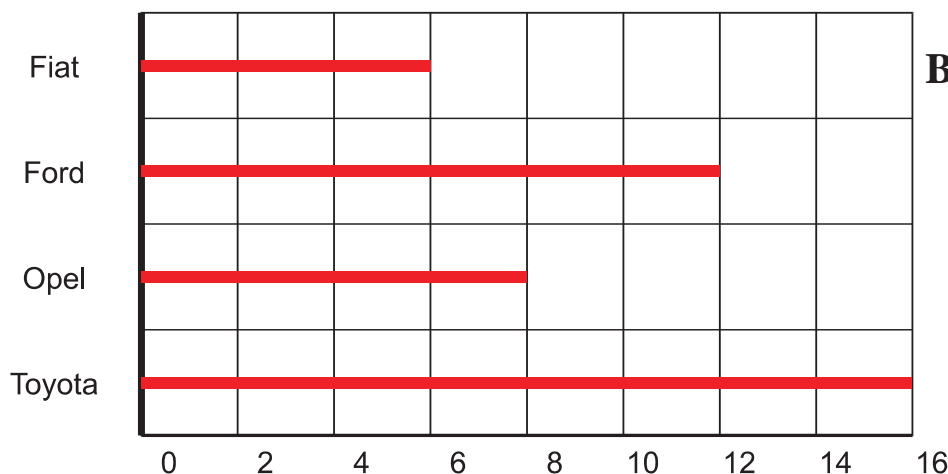

Barra-chairt Líneach Chothrománach

Freagair na ceistanna ar an leathanach thall, agus úsáid an t-eolas ar na barra-chairteacha líneacha thuas.

Arbh iad na freagraí céanna a fuair tú?

An Ceannach Peitрил ag Líon Tí
Sa tSeachtain
 Eanáir 2006

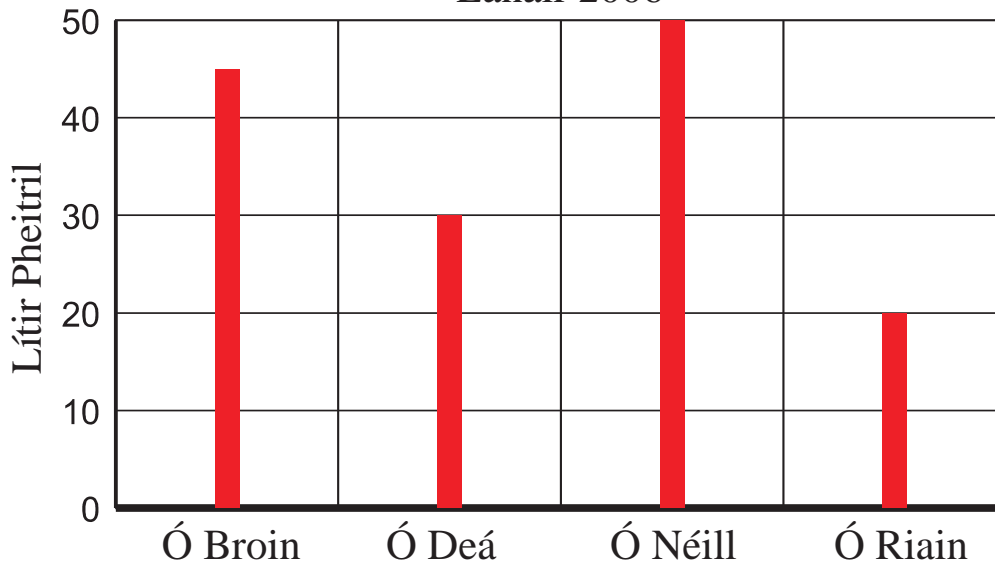

① Cé mhéad lítear peitрил a ceannaíodh ar fad?

② Cén méid peitрил ar meán a cheannaigh gach teaghlach?

③ Cé acu teaghlach a cheannaigh an méid is mó?

④ Cén méid de bhreis ar an meán a cheannaigh an teaghlach sin?

⑤ Cé acu teaghlach a cheannaigh an méid is lú?

⑥ Cén céatadán den iomlán a cheannaigh muintir Uí Dheá?

 %

Is mar seo a chaith cailín áirithe lá iomlán 24 uair a chloig:
 25% ar scoil; $8\frac{1}{3}\%$ ag breathnú ar an teilifís agus ag úsáid an ríomhaire;
 $33\frac{1}{3}\%$ ina codladh; $8\frac{1}{3}\%$ ag léamh; $12\frac{1}{2}\%$ ag spraoi; $12\frac{1}{2}\%$ ag gabháil
 do rudaí eile.

Imeachtaí Laethúla

Cailín Scoile

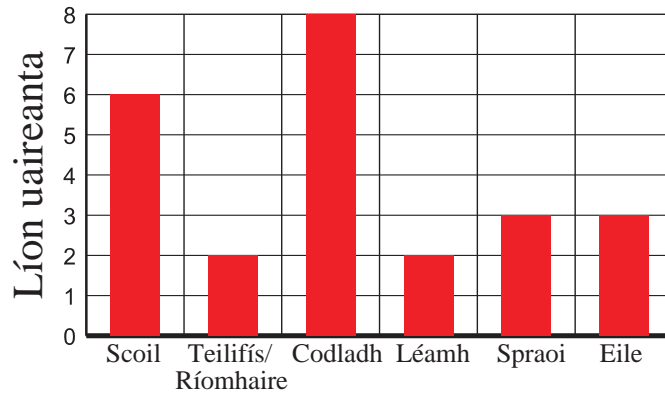

Airgead Póca Rang 5

Scoil Radharc an tSléibhe

2007

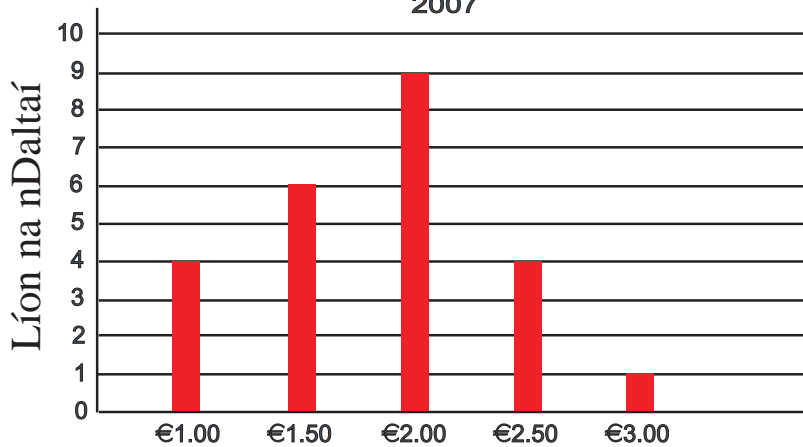

① Cad atá á léiriú ar an ais chothrománach?

② Cad atá á léiriú ar an ais cheartingearach?

③ Cé mhéad dalta a fhaigheann €1.50?

④ Cé mhéad dalta a fhaigheann €2.00?

⑤ Cé mhéad dalta atá sa rang?

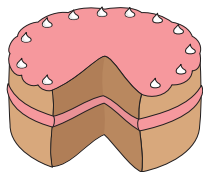

Píchairteanna

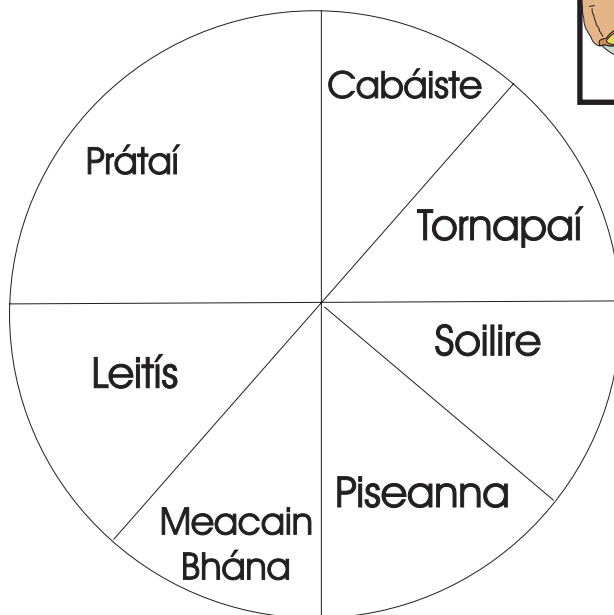
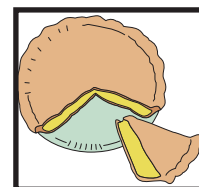

①

(a) Cén codán den ghairdín atá faoi phrátaí?

(b) Cén codán den ghairdín atá faoi chabáiste?

Ár rogha caitheamh aimsire.

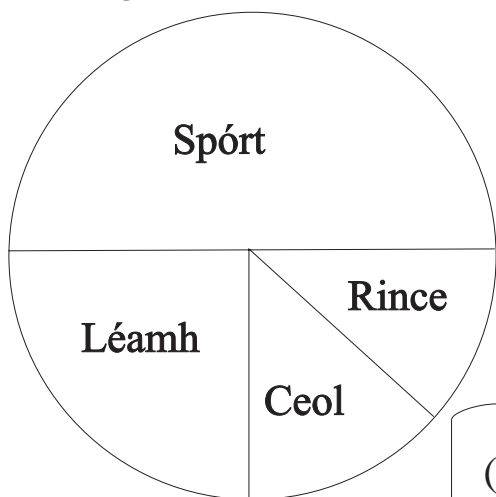

(a) Cén codán den rang arb é an spórt a rogha?

(b) Cén codán den rang arb é an léamh a rogha?

(c) Cén codán den rang arb é an rince a rogha?

Dath Gruaige

Rang 5

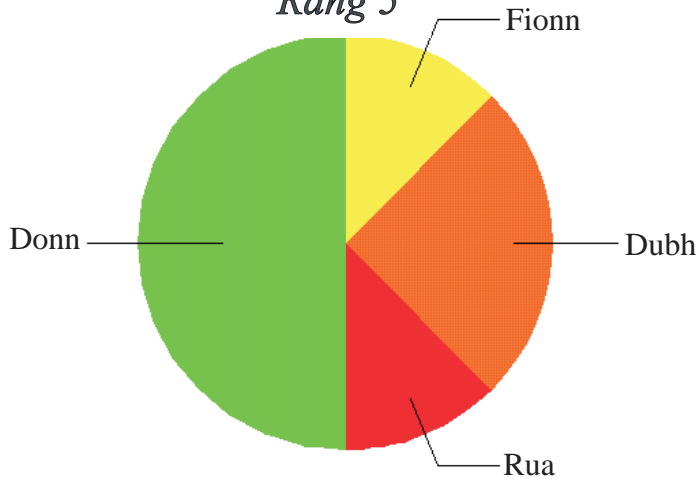

①

32 dalta atá i Rang 5.

- (a) Cé mhéad dalta a bhfuil gruaig fhionn orthu
- (b) Cé acu dath is coitianta?
- (c) Cé mhéad dalta a bhfuil gruaig dhonn orthu?
- (d) Cén céatadán a bhfuil gruaig rua orthu?

Bricfeasta

Rang 5

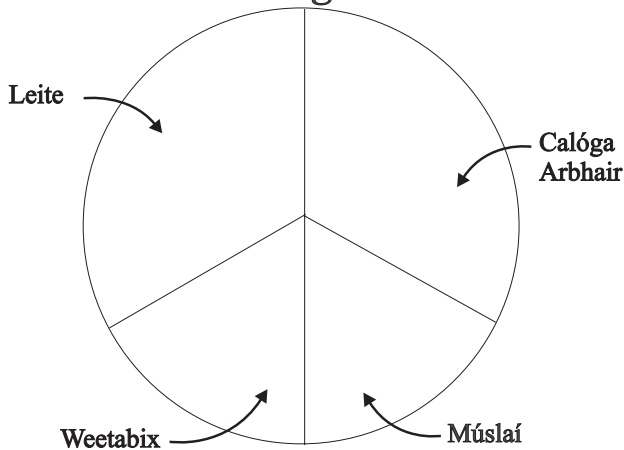

②

- (a) Cén codán den rang a itheann leite?
- (b) Cén codán a itheann *Weetabix*?
- (c) Cén codán a itheann calóga arbhair nó múslaí?

Rogha Spórt

Rang 5

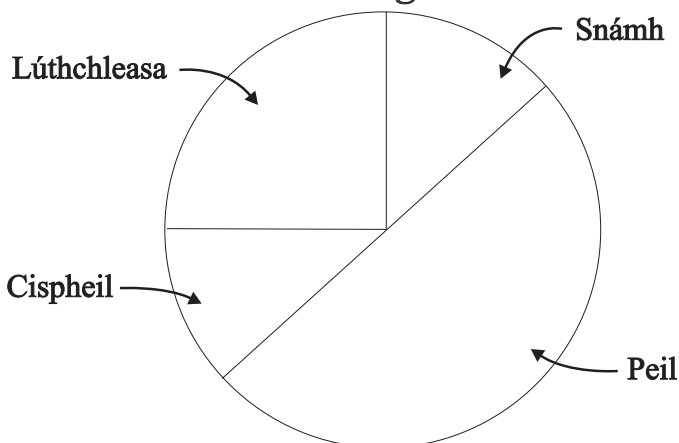

③

- (a) Cé mhéad dalta arb é snámh a rogha?
- (b) Cé mhéad dalta arb iad lúthchleasa a rogha?
- (c) Cé mhéad dalta arb í peil a rogha?

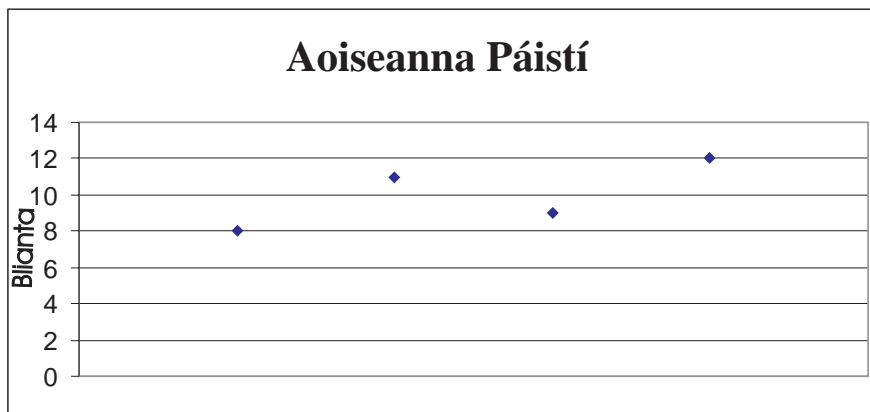

Aoiseanna 4 pháiste áta á léiriú ar an bponcghraf thuas.

① Cén aois atá acu ar meán?

② Tarraing píchart a léireoidh an t-eolas seo a leanas go cruinn.

Na deochanna a díoladh i siopa, lá brothallach samhraidh.

28 lítear *7Up*, 40 lítear líomanáide, 25 lítear oráiste, 34 lítear *Coca Cola*.

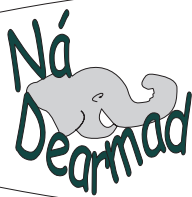

Cruth soladach é ochtaihéadrán a mbíonn
ocht n-aghaidh air.
Bíonn gach aghaidh triantánach.

Graif

Teascóga

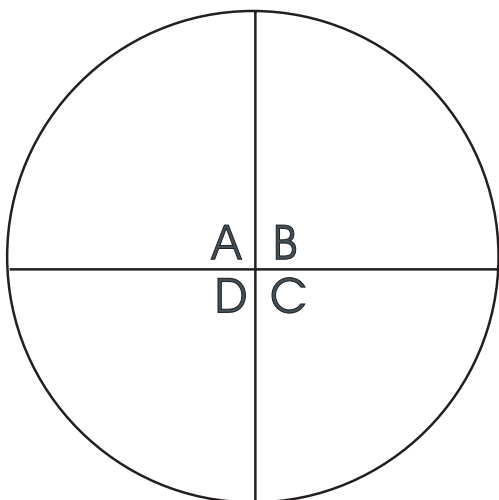

Rothlú iomlán sin 360° . Is é sin, tá 360° i lár an chiorcail.

Uillinneacha 90° iad A, B, C, agus D.
($90^\circ = \frac{1}{4}$ de 360°).

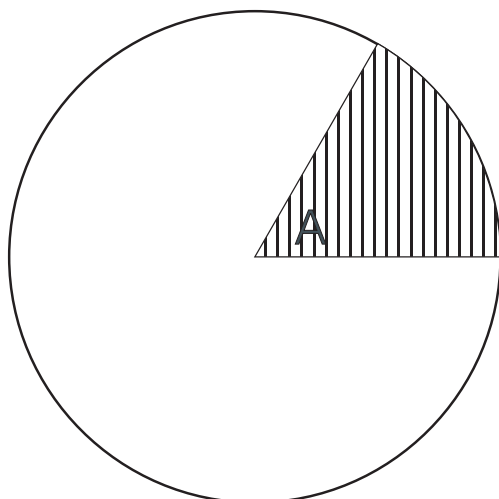

An uillinn A = 60° .

$$\frac{60}{360} = \frac{1}{6}$$

Tá an $\frac{1}{6}$ den chiorcal ar fad sa teascóg stríocach.

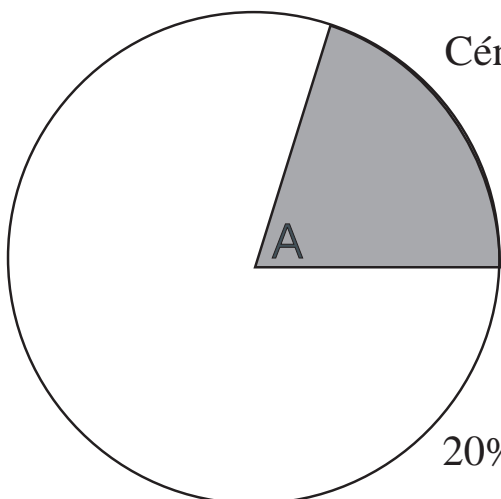

Cén céatadán d'achar an chiorcail atá scáthaithe?

An uillinn A = 72° .

$$\frac{72}{360} \times \frac{100}{1} = 20\%$$

20% den chiorcal iomlán atá sa teascóg scáthaithe.

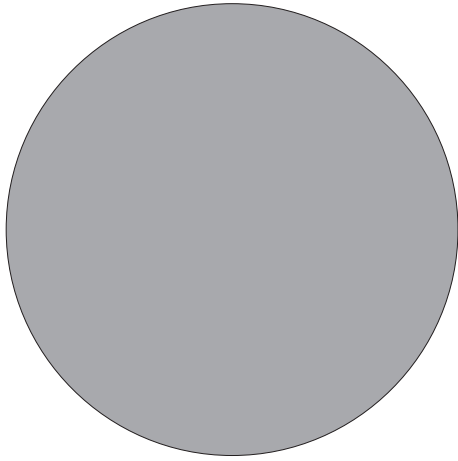

Ciorcal agus é scáthaithe go hiomlán.
D'fhéadfaí a rá go bhfuil 100% de scáthaithe.

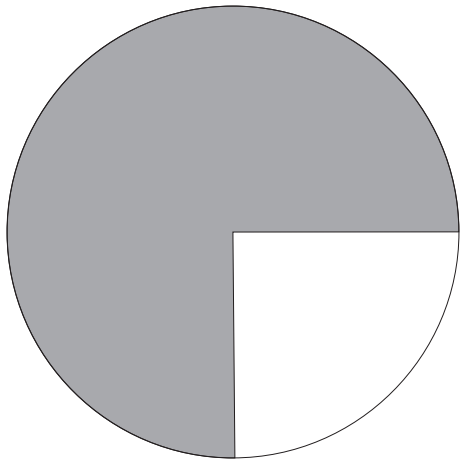

Teascóg den chiorcal seo atá
scáthaithe. Is ionann an teascóg
scáthaithe agus 75% den chiorcal.

$$75\% \text{ de } 360^\circ = 270^\circ.$$

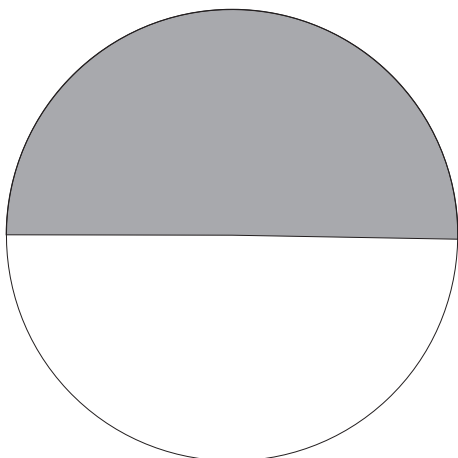

Teascóg den chiorcal seo atá
scáthaithe. Is ionann an teascóg
scáthaithe agus 50% den chiorcal.

$$50\% \text{ de } 360^\circ = 180^\circ.$$

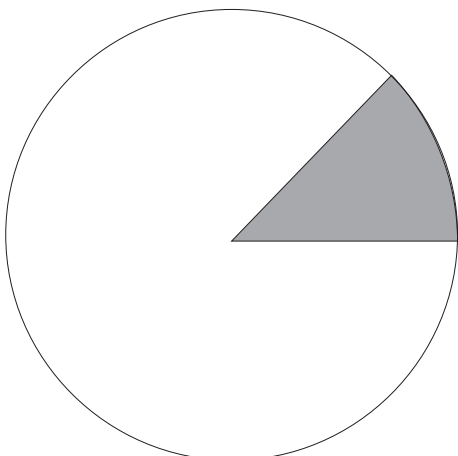

Teascóg den chiorcal seo atá
scáthaithe. Is ionann an teascóg
scáthaithe agus $12\frac{1}{2}\%$ den chiorcal.

$$12\frac{1}{2}\% \text{ de } 360^\circ = 45^\circ.$$

Úsáid d'uillinntomhas agus faigh an codán de gach ciorcal thíos atá scáthaithe.

①

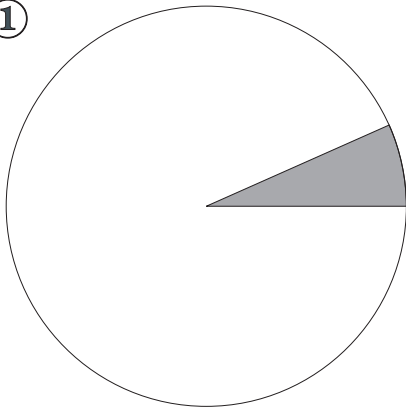

A

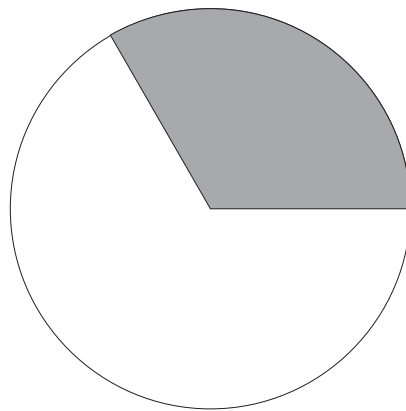

B

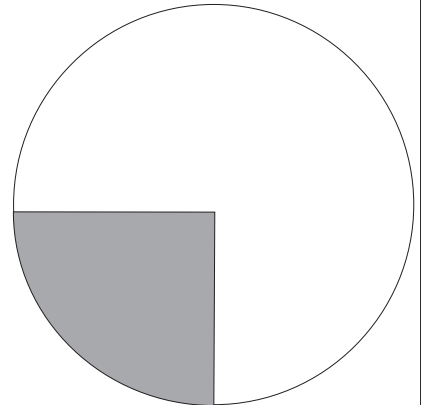

C

Úsáid d'uillinntomhas agus faigh an codán de gach ciorcal thíos atá scáthaithe.

②

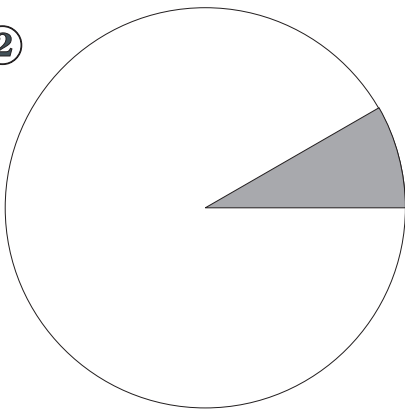

A

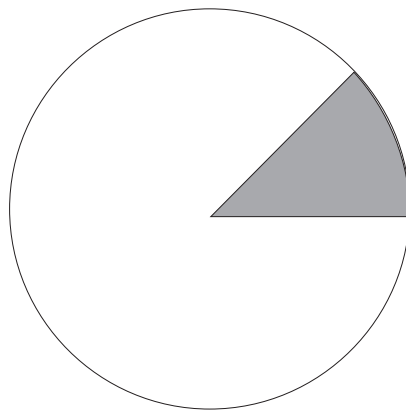

B

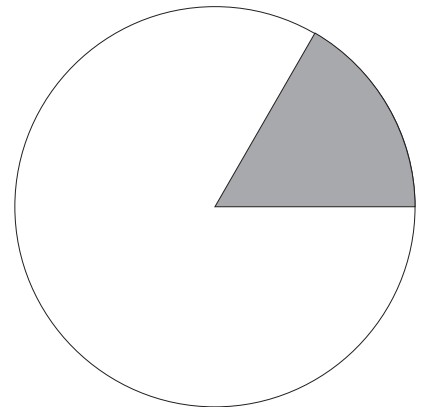

C

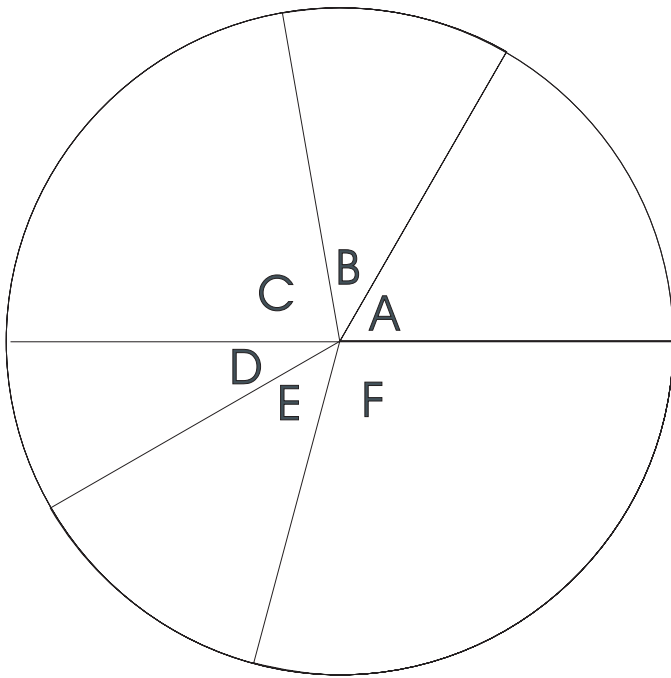

Úsáid d’uillinntomhas chun na huillinneacha a thomhas.

Cén codán den phióg iomlán atá i ngach slisne ar leith?

An Uillinn	An Tomhas	An Codán
A	◦	
B	◦	
C	◦	
D	◦	
E	◦	
F	◦	

Úsáid d’uillinntomhas chun na huillinneacha a thomhas.

Cén codán den phióg iomlán atá i ngach slisne ar leith?

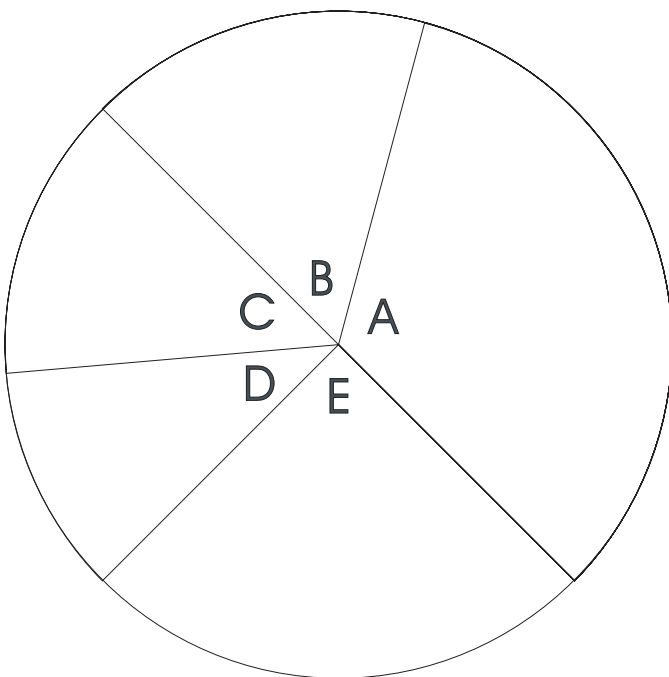

An Uillinn	An Tomhas	An Codán
A	◦	
B	◦	
C	◦	
D	◦	
E	◦	

Úsáid do chompás agus d'uillinntomhas chun na teascóga seo a thógáil.

- ① (a) 20% de chiorcal (b) $33\frac{1}{3}$ % de chiorcal
 (c) $12\frac{1}{2}$ % de chiorcal (d) 40% de chiorcal
 (e) 10% de chiorcal (f) $\frac{3}{4}$ de chiorcal
 (g) $\frac{2}{3}$ de chiorcal (h) $\frac{1}{5}$ de chiorcal

- ② **Sampla:** Bhí 60 ainmhí ag feirmeoir ar a fheirm: 30 caora, 15 bhó, 12 mhuc agus 3 chapall. Léirigh an t-eolas ar phíchart.

Na caoirigh ina gcéatadán de na hainmhithe go léir = $\frac{30}{60} \times \frac{100}{1} = 50\% = 180^\circ$

Na ba ina gcéatadán de na hainmhithe go léir = $\frac{15}{60} \times \frac{100}{1} = \square \% = 90^\circ$

Na muca ina gcéatadán de na hainmhithe go léir = $\frac{12}{60} \times \frac{100}{1} = 20\% = 72^\circ$

Na capaill ina gcéatadán de na hainmhithe go léir = $\frac{3}{60} \times \frac{100}{1} = 5\% = \square^\circ$

Na hAinmhithe ar an bhFheirm

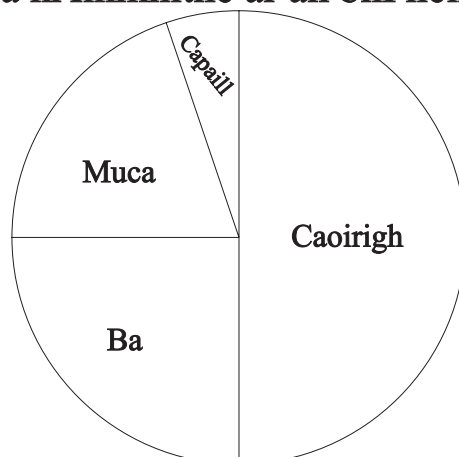

① 240 dalta atá i scoil.

Siúlann 80 acu ar scoil.

Tagann 60 ar an mbus.

Rothaíonn 30 ar scoil

Tagann an chuid eile ar scoil i ngluaisteáin.

Léirigh an t-eolas ar phíchart.

② Tá 400 milseán i mbosca. Léiríonn an phíchart na cineálacha éagsúla milseán.

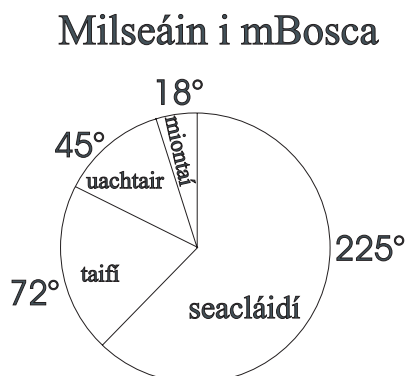

Cé mhéad

(a) Mionta

(b) Seacláid

atá sa bhosca?

Fad

An méadar an t-aonad caighdeánach agus fad á thomhas. Sín amach do dhá lámh amhail is go raibh tú ag siúl ar théad rite. Beagáinín de bhreis ar mhéadar atá san fhad idir do dhá bhos.



Tomhais rudaí éagsúla sa seomra ina méadair. Úsáid téip mhéadrach más féidir. 100 cm atá in 1 méadar. Fad 30 cm a bhíonn sa ghnáthrialóir scoile. Dá réir sin 3 rialóir agus 10 cm = 1 m.

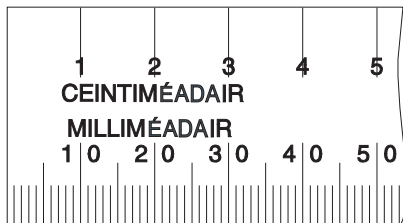

Má smaoiníonn tú ar shuimeanna airgid, cabhróidh sé leat agus suimeanna ceintiméadair á ndéanamh.

$$50 \text{ cent} = \text{€}0.50$$

$$50 \text{ cm} = \frac{1}{2} \text{ m} = 0.5 \text{ méadar (m)}$$

Cé mhéad ceintiméadar atá iontu seo a leanas?

① (a) 2 m =

(b) 2½ m =

(c) 6 m =

(d) 0.5 m =

(e) 0.75 m =

(f) 0.25 m =

② (a) 0.2 m =

(b) 0.1 m =

(c) 0.3 m =

(d) 5.5 m =

(e) 0.4 m =

(f) 3.8 m =

Cé mhéad ceintiméadar atá i ngach ceann díobh seo a leanas?

① (a) $4.2 \text{ m} =$

(b) $9.5 \text{ m} =$

(c) $1.82 \text{ m} =$

(d) $4.03 \text{ m} =$

② (a) $51.6 \text{ m} =$

(b) $23.9 \text{ m} =$

(c) $\frac{1}{2} \text{ m} =$

(d) $\frac{1}{4} \text{ m} =$

③ Cé mhéad cm atá i ngach ceann díobh seo a leanas?

a) 3 m

b) $\frac{1}{4} \text{ m}$

c) 1 m

d) $\frac{3}{4} \text{ m}$

e) $1\frac{1}{2} \text{ m}$

f) 2 m

g) $\frac{1}{2} \text{ m}$

h) 4 m

i) $2\frac{1}{4} \text{ m}$

j) $1\frac{3}{4} \text{ m}$

k) $\frac{1}{10} \text{ m}$

l) $\frac{9}{10} \text{ m}$

④ Cé mhéad cm atá i ngach ceann díobh seo a leanas?

a. $0.14 \text{ m} =$ cm

g. $0.82 \text{ m} =$ cm

b. $0.96 \text{ m} =$ cm

h. $3.41 \text{ m} =$ cm

c. $1.32 \text{ m} =$ cm

i. $0.02 \text{ m} =$ cm

d. $4.76 \text{ m} =$ cm

j. $0.77 \text{ m} =$ cm

e. $1.56 \text{ m} =$ cm

k. $2.09 \text{ m} =$ cm

f. $2.03 \text{ m} =$ cm

l. $1.68 \text{ m} =$ cm

⑤ Scríobh iad seo ina méadair, agus an pointe deachúlach in úsáid.

$2 \text{ m } 19 \text{ cm} =$ m

$8 \text{ m } 94 \text{ cm} =$ m

Bíonn gach ceintiméadar roinnte ina dheich bpáirt chothroma ar a dtugtar milliméadair.

10 mm atá i 1 cm.

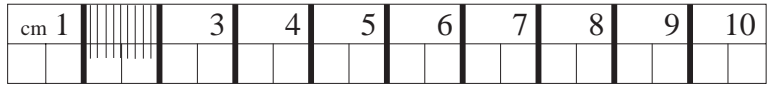

Gearr amach píosa cairtchláir agus é 10 cm ar fad.

Roinn gach ceintiméadar ina 10 bpáirt chothroma. 100 rannán bídeach atá ar an gcairtchlár anois. Milliméadar (mm) a thugtar ar gach ceann díobh.

- ① Déan garmheastachán ar fhad an bhioráin seo thíos ina mm. Seiceáil tomhas cruinn an bhioráin le do rialóir ansin. _____

Mo gharmheastachán féin:

An tomhas cruinn:

- ②  Tomhais tiús boinn €2.

- ③  Tomhais tiús caiséid cheoil.

35 mm = 3.5 cm *nó* 3 cm 5 mm

Déan iad seo thíos ar an mbealach céanna.

① (a) 26 mm =

(b) 41 mm =

(c) 33 mm =

(d) 55 mm =

(e) 82 mm =

(f) 64 mm =

(g) 96 mm =

(h) 78 mm =

(i) 109 mm =

(j) 13 mm =

② (a) 19 mm =

(b) 4 mm =

(c) 2 mm =

(d) 5 mm =

(e) 6 mm =

(f) 3 mm =

(g) 8 mm =

(h) 7 mm =

(i) 10 mm =

(j) 9 mm =

1 m = 100 cm = 1000 mm

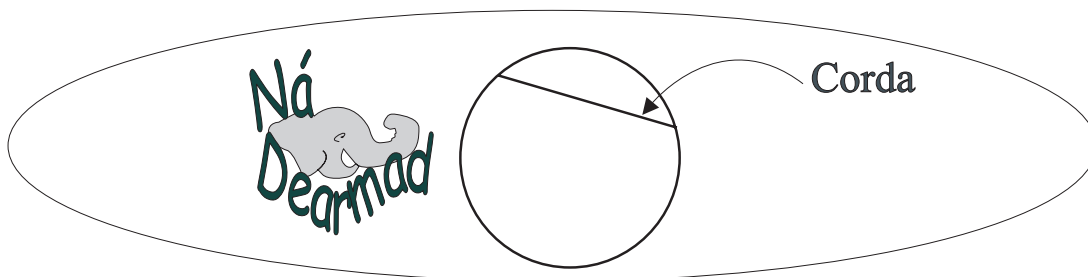

$$1 \text{ mm} = \frac{1}{1000} \text{ m} = 0.001 \text{ m}$$

$$1 \text{ cm} = \frac{1}{100} \text{ m} = 0.01 \text{ m}$$

Scríobh iad seo thíos ina gceintiméadair agus pointe deachúlach in úsáid.

- ① (a) 851 mm =
- (b) 497 mm =
- (c) 961 mm =
- (d) 377 mm =
- (e) 66 mm =

- ② (a) 614 mm =
- (b) 731 mm =
- (c) 282 mm =
- (d) 492 mm =
- (e) 953 mm =

Cosán cam a bhí le siúl ag na ceithre fheithid seo. Tomhais an fad a bhí le siúl ag gach feithid díobh ina mhilliméadair.

③ 

④ 

⑤ 

⑥ 

Tá dhá bhealach againn chun ceintiméadair agus milliméadair a shuimiú agus a dhealú.

$$\begin{array}{r}
 \text{cm} \quad \text{mm} \\
 1 \quad 3 \\
 2 \quad 7 \\
 + \quad 4 \quad 5 \\
 \hline
 8 \quad 5
 \end{array}$$

nó

$$\begin{array}{r}
 1.3 \text{ cm} \\
 2.7 \text{ cm} \\
 + \quad 4.5 \text{ cm} \\
 \hline
 8.5 \text{ cm}
 \end{array}$$

Bain triail astu seo anois.

①

$$\begin{array}{r}
 \text{cm} \quad \text{mm} \\
 2 \quad 6 \\
 2 \quad 7 \\
 + \quad 1 \quad 5 \\
 \hline
 \end{array}$$

②

$$\begin{array}{r}
 2.6 \text{ cm} \\
 2.7 \text{ cm} \\
 + \quad 1.5 \text{ cm} \\
 \hline
 \end{array}$$

③

$$\begin{array}{r}
 \text{cm} \quad \text{mm} \\
 4 \quad 5 \\
 - \quad 1 \quad 6 \\
 \hline
 \end{array}$$

④

$$\begin{array}{r}
 4.5 \text{ cm} \\
 - \quad 1.6 \text{ cm} \\
 \hline
 \end{array}$$

⑤

$$\begin{array}{r}
 \text{m} \quad \text{mm} \\
 3 \quad 84 \\
 \quad 194 \\
 + \quad 2 \quad 205 \\
 \hline
 \end{array}$$

⑥

$$\begin{array}{r}
 \text{m} \quad \text{mm} \\
 8 \quad 271 \\
 \quad 1 \quad 933 \\
 + \quad 8 \quad 299 \\
 \hline
 \end{array}$$

⑦

$$\begin{array}{r}
 \text{m} \quad \text{mm} \\
 8 \quad 47 \\
 - \quad 2 \quad 183 \\
 \hline
 \end{array}$$

⑧

$$\begin{array}{r}
 \text{m} \quad \text{mm} \\
 9 \quad 33 \\
 - \quad 3 \quad 48 \\
 \hline
 \end{array}$$



Is é a bhíonn i gceist le himlíne,
an fad timpeall an imill.

Sampla:

$$2 \text{ m } 50 \text{ cm} + 70 \text{ cm} + 2 \text{ m } 8 \text{ cm}$$

$$\begin{array}{r} \text{athscríobh mar:} \quad 2.5 \\ \quad \quad \quad \quad \quad 0.7 \\ \quad \quad \quad \quad \quad + 2.08 \\ \hline \text{Freagra} = \quad \quad \quad 5.28 \text{ m} \end{array}$$

Déan iad seo thíos. Scríobh an bealach eile iad ar dtús.

①

(a) $3 \text{ m } 45 \text{ cm} + 4 \text{ m } 75 \text{ cm} + 2 \text{ m } 8 \text{ cm}$

(b) $3 \text{ m } 72 \text{ cm} + 4 \text{ m } 25 \text{ cm} + 2 \text{ m } 61 \text{ cm}$

(c) $5 \text{ m } 25 \text{ cm} + 65 \text{ cm} + 5 \text{ m } 12 \text{ mm}$

(d) $8 \text{ m } 28 \text{ cm} + 1 \text{ m } 55 \text{ cm} + 2 \text{ m } 40 \text{ cm}$

(e) $5 \text{ m} + 3 \text{ m } 80 \text{ cm} + 2 \text{ m } 6 \text{ mm}$

(f) $4 \text{ m } 85 \text{ cm} + 3 \text{ m } 89 \text{ cm} + 3 \text{ m } 27 \text{ cm}$

②

(a) $4 \text{ m } 60 \text{ cm} - 2 \text{ m } 72 \text{ cm}$

(b) $8 \text{ m } 28 \text{ cm} - 3 \text{ m } 35 \text{ cm}$

(c) $5 \text{ m } 8 \text{ mm} - 2 \text{ m } 36 \text{ cm}$

(d) $4 \text{ m } 28 \text{ mm} - 2 \text{ m } 40 \text{ cm}$

(e) $7 \text{ m } 35 \text{ mm} - 78 \text{ cm}$

(f) $6 \text{ m} - 2 \text{ m } 48 \text{ cm}$



240 cent = €2.40

240 cm = 2.4 m

Freagair iad seo a leanas:

①

(a) $2 \text{ m } 27 \text{ mm} + 486 \text{ mm} + 471 \text{ cm} + 2 \text{ m } 28 \text{ cm} =$

(b) $2 \text{ m } 375 \text{ mm} + 2.09 \text{ m} + 55 \text{ mm} + 79 \text{ cm} =$

(c) $3 \text{ m } 18 \text{ mm} + 3.47 \text{ m} + 450 \text{ cm} + 2 \text{ m } 11 \text{ cm} =$

(d) $59 \text{ cm} + 2.008 \text{ m} + 1 \text{ m } 872 \text{ mm} + 722 \text{ cm} =$

(e) $12 \text{ cm } 8 \text{ mm} + 5.57 \text{ m} + 2 \text{ m } 786 \text{ mm} + 2 \text{ m } 31 \text{ cm} =$

(f) $6 \text{ m } 37 \text{ mm} - 4 \text{ m } 288 \text{ mm} =$

(g) $12 \text{ m } 58 \text{ cm} - 8 \text{ m } 73 \text{ cm} =$

②

(a) Faigh imlíne **A** agus imlíne **B** ina gceintiméadair.

(b) Cé mhéad cm níos faide ná cruth amháin atá an cruth eile?

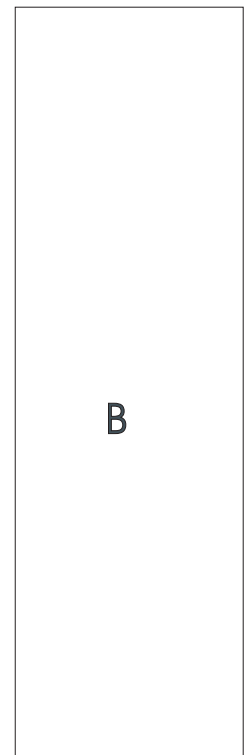
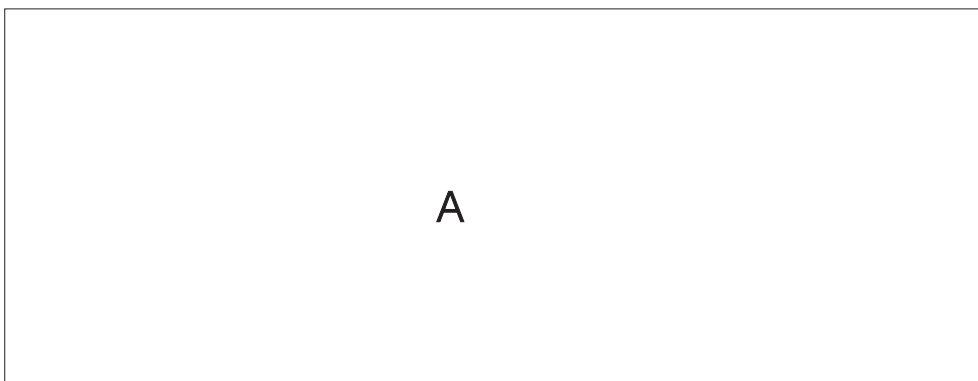

③

Faigh imlíne chruth **C** ina milliméadair.

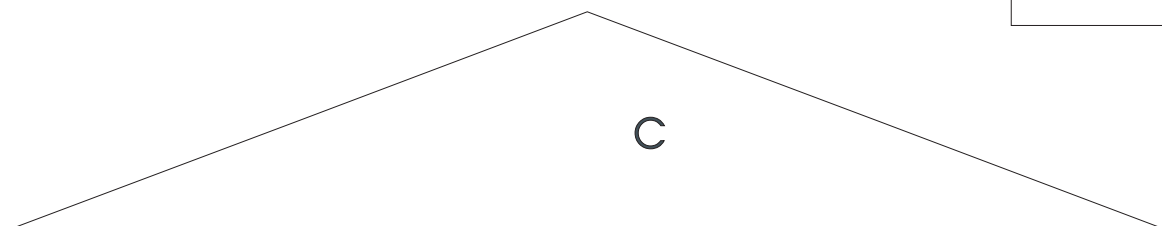

- ① Cheannaigh Mamaí 4.5 m d'éadach cuirtíní. B'in 3 oiread is a cheannaigh Aintín Úna den éadach céanna.
(a) Cén méid a cheannaigh an bheirt acu le chéile?
(b) Faigh costas iomlán an éadaigh. Chosain sé €4.85 an méadar.
- ② Barra iarainn atá 4.5 m ar fad, chosain sé €7.10.
Cé mhéad é sin in aghaidh an mhéadair?
- ③ Balla a bhí 20 m ar fad, chosnódh sé €10.30 chun 8.35 m den bhalla a phéinteáil. Céard a chosnódh sé chun an balla iomlán a phéinteáil?
- ④ Cé mhéad píosa sreinge 2.8 m ar fad is féidir a ghearradh ó chorna sreinge 22.4 m ar fad?
- ⑤ Cheannaigh siúinéir clár adhmaid a bhí 4 m ar fad. Ghearr sé ina dhá phársa é sa tslí go raibh píosa amháin 68 mm níos faide ná an píosa eile. Cén fad a bhí i ngach píosa ar leith?
- ⑥ $0.67 \times \square = 1.8023$
- ⑦ $193.8 \div 0.68 = \square$

Ciliméadair agus méadair.

Úsáidtear ciliméadair nuair a bhíonn réimsí an-fhada le tomhas.



1000 m atá i gciliméadar (km).

① Scríobh ina méadair:

$4 \text{ km} = \boxed{}$

$7 \text{ km} = \boxed{}$

$10 \text{ km} = \boxed{}$

② Cé mhéad méadar atá in:

$0.5 \text{ km} = \boxed{}$

$4.5 \text{ km} = \boxed{}$

$8.5 \text{ km} = \boxed{}$

③ Scríobh iad seo a leanas ina méadair.

$a) 2 \text{ km } 100 \text{ m} = \boxed{}$

$b) 5 \text{ km } 400 \text{ m} = \boxed{}$

$c) 3 \text{ km } 750 \text{ m} = \boxed{}$

$d) 7 \text{ km } 250 \text{ m} = \boxed{}$

④ Ceangail na faid chothroma

$6\frac{1}{2} \text{ km} \qquad 8500 \text{ m}$

$5\frac{1}{4} \text{ km} \qquad 5250 \text{ m}$

$7.5 \text{ km} \qquad 4500 \text{ m}$

$4.5 \text{ km} \qquad 6500 \text{ m}$

$8.5 \text{ km} \qquad 7500 \text{ m}$

⑤

$10\frac{3}{4} \text{ km} \qquad 9100 \text{ m}$

$9\frac{1}{10} \text{ km} \qquad 11\,300 \text{ m}$

$5\frac{1}{5} \text{ km} \qquad 10\,750 \text{ m}$

$11\frac{3}{10} \text{ km} \qquad 6800 \text{ m}$

$6\frac{4}{5} \text{ km} \qquad 5200 \text{ m}$

Tabhair freagraí na gceisteanna seo a leanas go dtí trí áit dheachúlacha.

① Cosnaíonn peitreal 59 cent an lítear. Cén costas atá ar pheitreal do thuras 105 km i ngluaisteán a dhéanann 15 km in aghaidh an lítir?

② Taistealaíonn traein ar mheánluas 75 km san uair. Cén fad a thaisteal sí in 1 uair 30 nóim.?

③ Cé mhéad ama a ghlacfaidh sé turas 585 km a dhéanamh agus tú ag taisteal ar luas 65 km san uair?

④ $9\frac{1}{8}$ km + 350 m + 7 km + 60 m – $7\frac{3}{4}$ km =

⑤ D'fhógair *AA Roadwatch* go raibh 6.75 km de bhóthar áirithe dúnta de bharr tuile bháistí. B'in 0.35 d'aistear a bhí le déanamh. Cén fad a bhí san aistear iomlán?

⑥ 3 km 147 m × 4 =

⑦ 8 km 184 m ÷ 31 =

⑧ 3 km 190 m × 5.7 =

⑨ 7 km 95 m ÷ 43 =

⑩ 6.093 km × 12 =

Meáchan

$$1000 \text{ gram} = 1 \text{ cileagram}$$

$$1000 \text{ g} = 1 \text{ kg}$$

$$1 \text{ g} = \frac{1}{1000} \text{ kg} = 0.001 \text{ kg}$$

$$36 \text{ g} = \frac{36}{1000} \text{ kg} = 0.036 \text{ kg}$$

Is féidir 2675 g a scríobh sa riocht 2.675 kg

Is féidir 6.075 kg a scríobh sa riocht 6075 g

Scríobh iad seo thíos ina ngram.

①

(a) 1.68 kg = gram

(b) 7.35 kg = gram

(c) 4.45 kg = gram

(d) 4.045 kg = gram

(e) 1.36 kg = gram

(f) 4.67 kg = gram

②

(a) 1.01 kg = gram

(b) 3.50 kg = gram

(c) 7.23 kg = gram

(d) 5.025 kg = gram

(e) 1.679 kg = gram

(f) 6.00 kg = gram

Scríobh iad seo thíos ina gcileagraim.

①

(a) $1348 \text{ g} = \boxed{} \text{ kg}$

(b) $36 \text{ g} = \boxed{} \text{ kg}$

(c) $728 \text{ g} = \boxed{} \text{ kg}$

(d) $8462 \text{ g} = \boxed{} \text{ kg}$

(e) $9 \text{ g} = \boxed{} \text{ kg}$

(f) $97 \text{ g} = \boxed{} \text{ kg}$

②

(a) $228 \text{ g} = \boxed{} \text{ kg}$

(b) $78 \text{ g} = \boxed{} \text{ kg}$

(c) $345 \text{ g} = \boxed{} \text{ kg}$

(d) $80 \text{ g} = \boxed{} \text{ kg}$

(e) $3720 \text{ g} = \boxed{} \text{ kg}$

(f) $100 \text{ g} = \boxed{} \text{ kg}$

③ (a) $364 \text{ g} + 73 \text{ g} + 3 \text{ kg} + 6 \text{ kg} + 287 \text{ g} + 5 \text{ g} = \boxed{}$

(b) $2865 \text{ g} + 285 \text{ g} + 6 \text{ kg} + 1 \text{ kg} + 3 \text{ g} + 47 \text{ g} = \boxed{}$

(c) $89 \text{ g} + 100 \text{ g} + 8 \text{ g} + 8002 \text{ g} + 20 \text{ g} + 10 \text{ g} = \boxed{}$

(d) $8 \text{ g} + 80 \text{ g} + 880 \text{ g} + 467 \text{ g} + 10 \text{ kg} + 25 \text{ g} = \boxed{}$

(e) $1100 \text{ g} + 273 \text{ g} + 46 \text{ g} + 2800 \text{ g} + 2 \text{ kg} + 2 \text{ g} = \boxed{}$

①

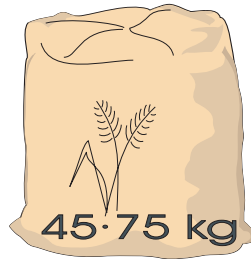

(a) Cé acu mála is troime?

(b) Cé mhéad níos troime ná an ceann eile atá sé?

②

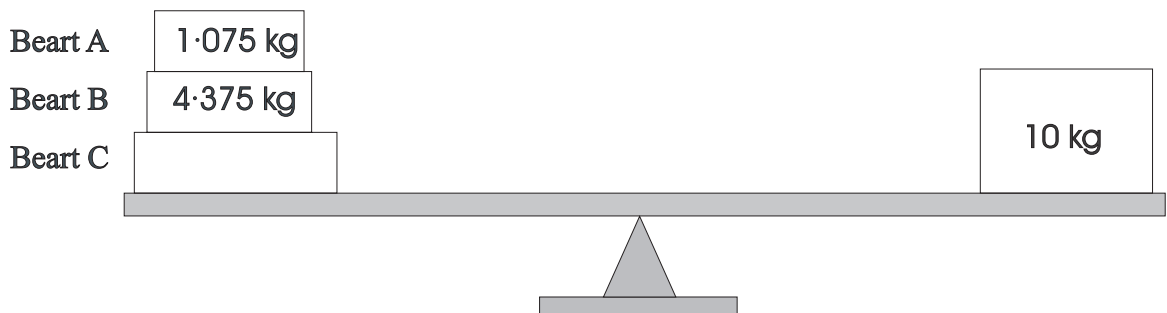

Cén meáchan atá i mBeart C?

③

Meánn Sorcha 53.48 kg. Meánn Seán 2 kg 625 g faoina bhun sin.
Cén meáchan atá i Seán?

④

Meánn bosca bananaí 14 kg 65 g. Faigh meáchan iomlán 9 mbosca bananaí.

⑤

Cé mhéad paicéad 150 g is féidir a dhéanamh as 1.05 kg?

Toilleadh

1 lítear = 1000 millilítear
 nó 1 l = 1000 ml

$1 \text{ ml} = \frac{1}{1000} \text{ l} = 0.001 \text{ l}$

$85 \text{ ml} = \frac{85}{1000} \text{ l} = 0.085 \text{ l}$



333 ml

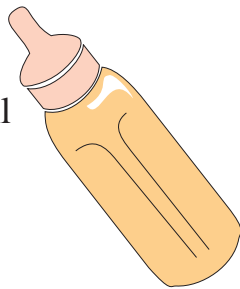

280 ml



250 ml

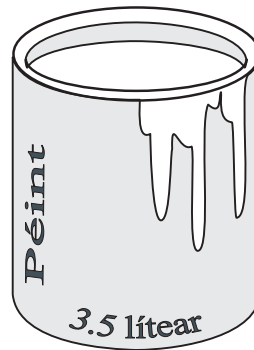

a thoilleann



- 1 lítear ●
- 750 ml ●
- 333 ml ●
- 280 ml ●
- 250 ml ●
- 3½ L ●

- i gcanna péinte
- i gcanna sú
- i gcupán tae
- i mbuidéal uisce mianraí
- i mbuidéal linbh
- i gcartán bainne

Féach na pictiúir ar Leathanach 21 - 1.

① Cé mhéad cupán uisce a thoillfeadh sa channa péinte?

② Cé mhéad uair a líonfá an buidéal linbh as cartán bainne?

③ An dthoillfeadh 8 gcanna sú sa channa péinte?

④ Cé mhéad millilítear atá i ngach ceann díobh seo?

- a) 1.3 l b) 10 l c) $3\frac{1}{2}$ l d) $12\frac{1}{2}$ l e) $1\frac{1}{4}$ l f) $2\frac{3}{4}$ l

⑤

5 l

$4\frac{1}{4}$ l

$7\frac{1}{2}$ l

$8\frac{1}{2}$ l

$6\frac{3}{4}$ l

is ionann é agus

→

5000 ml

4250 ml

7500 ml

6750 ml

8500 ml

⑥

2 l 300 ml

9 l 700 ml

3 l 130 ml

1 l 900 ml

is ionann é agus

→

9700 ml

1900 ml

2300 ml

3130 ml

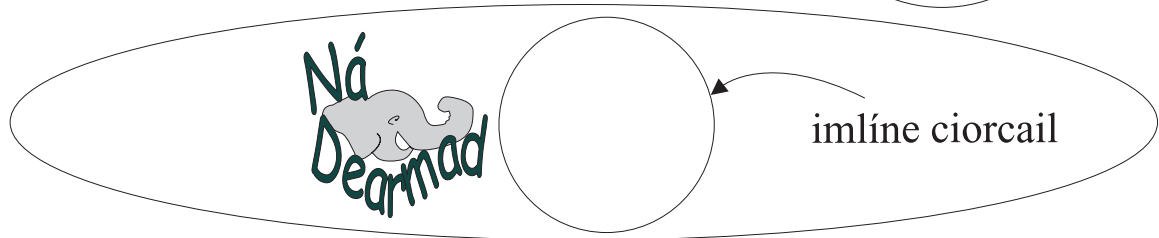

Scríobh iad seo ina ml

①

$5\frac{1}{4} l$

$4\frac{3}{5} l$

$7\frac{19}{1000} l$

$3\frac{3}{4} l$



Scríobh iad seo ina ml

②

$5\frac{4}{5} l$

$2\frac{9}{1000} l$

$3\frac{79}{1000} l$

$4\frac{1}{8} l$

$3\frac{5}{8} l$



Scríobh iad seo ina ml

③

$7\frac{7}{8} l$

$5\frac{1}{2} l$

$6\frac{7}{8} l$

$8\frac{3}{5} l$



①

Scríobh iad seo ina ml

$1\frac{1}{4} l$

$6\frac{4}{5} l$

$3.45 l$

$19.873 l$

②

Scríobh iad seo ina ml

$2\frac{1}{5} l$

$1.76 l$

$24\frac{1}{2} l$

$7.6 l$

③

Scríobh iad seo ina ml

$0.7 l$

$0.175 l$

$\frac{1}{4} l$

$1.4 l$

①

(a) $3\ l\ 475\ \text{ml} + 8\ l\ 955\ \text{ml} + 6\ l\ 45\ \text{ml} =$

(b) $3\ l\ 86\ \text{ml} + 5\ l\ 375\ \text{ml} + 7\ l\ 945\ \text{ml} =$

(c) $4\ l\ 6\ \text{ml} + 9\ l\ 295\ \text{ml} + 2\ l\ 905\ \text{ml} =$

(d) $8\ l\ 707\ \text{ml} + 4\ l\ 585\ \text{ml} + 5\ l\ 78\ \text{ml} =$

②

(a) $8\ l\ 325\ \text{ml} - 4\ l\ 678\ \text{ml} =$

(b) $9\ l\ 82\ \text{ml} - 3\ l\ 695\ \text{ml} =$

(c) $24\ l\ 7\ \text{ml} - 17\ l\ 244\ \text{ml} =$

(d) $19\ l\ 6\ \text{ml} - 14\ l\ 75\ \text{ml} =$

(a) $6\ l\ 75\ \text{ml} + 16.76\ l + 4\frac{59}{1000}\ l - 19.872\ l =$

(b) $4\frac{3}{5}\ l + 9\ l\ 285\ \text{ml} + 3\frac{3}{4}\ l - 11\ l\ 980\ \text{ml} =$

③

(c) $5\frac{1}{4}\ l + 5\ l\ 26\ \text{ml} + 7\frac{19}{100}\ l - 13.89\ l =$

(d) $4\ l\ 240\ \text{ml} + 7\ l\ 385\ \text{ml} + 2\ l\ 864\ \text{ml} - 9\ l\ 36\ \text{ml} =$

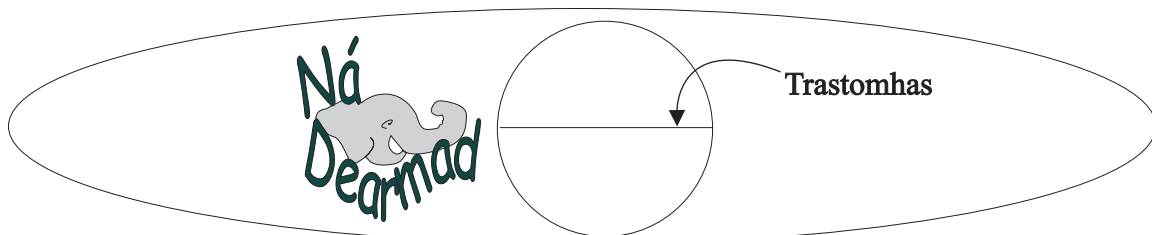

Fadhbanna

- ① Meascann Deirdre péint bhuí agus péint ghorm chun péint ghlas a dhéanamh. Caithfidh sí dhá pháirt de phéint bhuí a mheascadh le trí pháirt de phéint ghorm leis an dath glas áirithe atá uaithi a dhéanamh. Tá 100 ml den phéint bhuí aici agus 200 ml den phéint ghorm. Cad é an uasmhéid den phéint ghlas is féidir léi a dhéanamh?
- ② Cén costas atá ar 5.25 lítear fíona @ €6.20 an lítear?
- ③ 2.25 lítear bainne a úsáidtear sa teach gach lá.
- (a) Cén méid bainne a theastódh don bhliain ar fad?
- (b) Cé mhéad a chosnaíonn bainne na seachtaine más 64 cent atá ar lítear amháin?
- ④ Cé mhéad buidéal $\frac{1}{2}$ lítear is féidir a líonadh as soitheach ina bhfuil 126.2 lítear?
- ⑤ 98 cent atá ar bhuidéal 1 lítear oráiste. Tugtar 2 cent ar ais nuair a thugtar an buidéal ar ais go dtí an siopa. Cé mhéad a chosnóidh 9 lítear orm má thugaim na buidéil ar ais?

Cruthanna 3-T

(Solaid)

Cruthanna 3-thoiseacha (3-T) a thugtar ar chruthanna a bhfuil 3 thoise acu i.e.

fad

leithead

tiús

① An féidir leat ceithre chruth 3-T a aimsiú anseo?

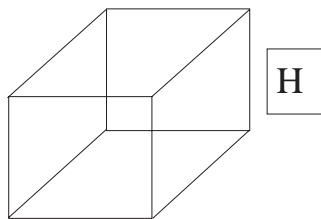
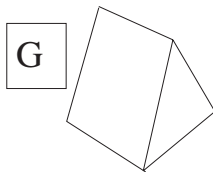
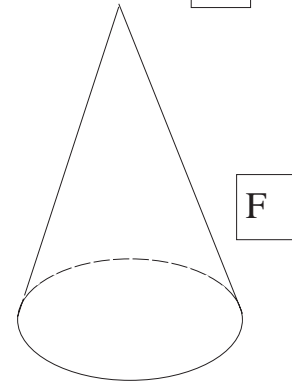
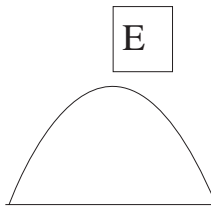
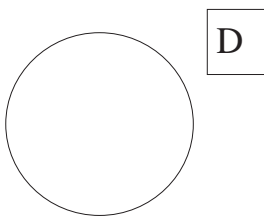
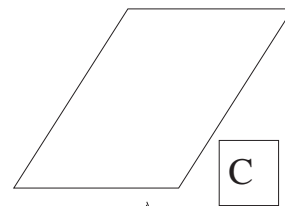
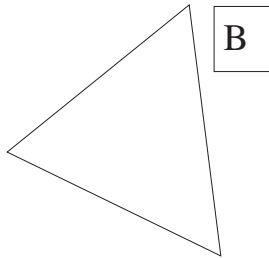
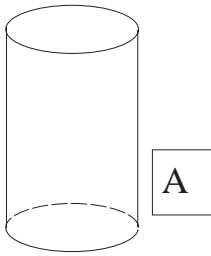

Meitseáil na cruthanna leis na hainmneacha cearta.

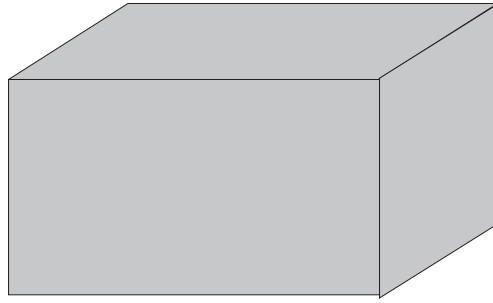
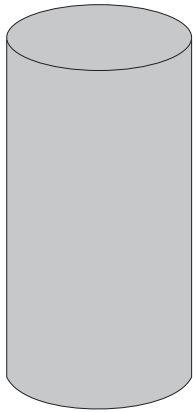

Sféar

Pirimid

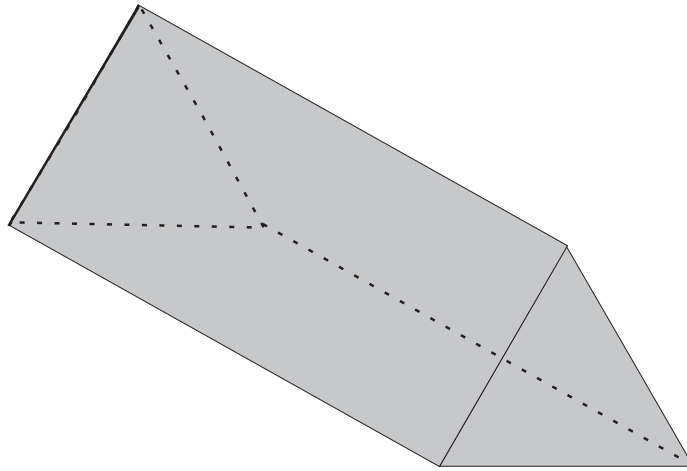
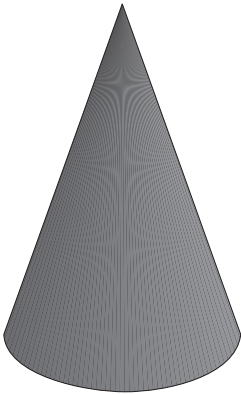

Priosma

Ciúbóideach



Ciúb

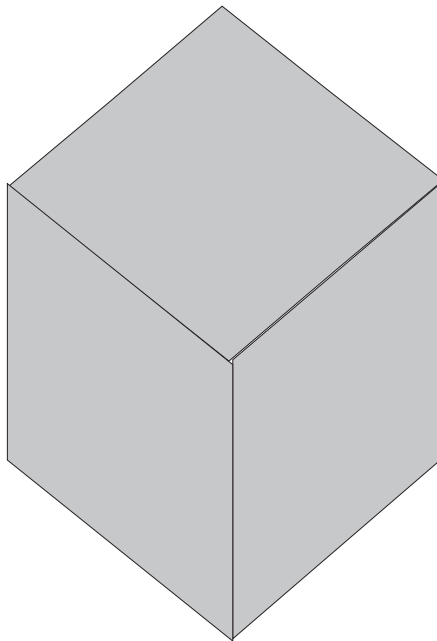

Cón

Sorcóir

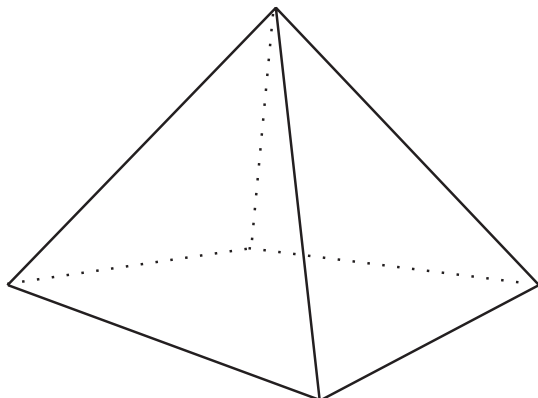

Bíonn

AGHAIDHEANNA

IMILL

REANNA

ar gach cruth 3-T.

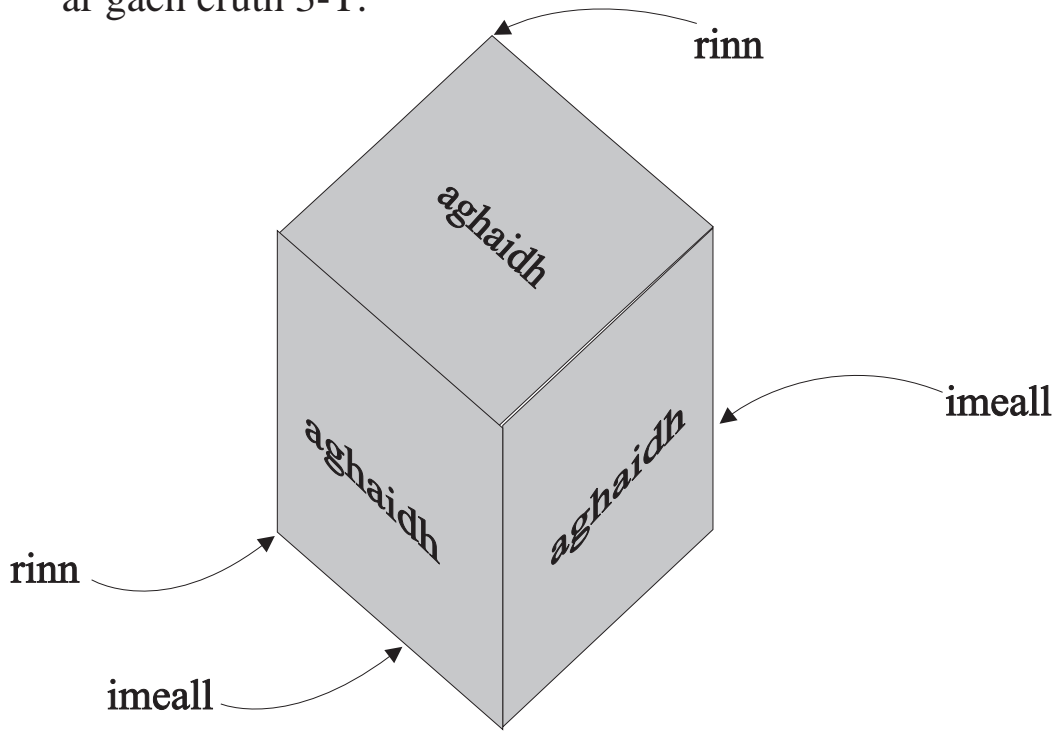

Ciúb a dhéanamh as líontán cairtchláir.

Céim 1

Gearr amach an cruth.

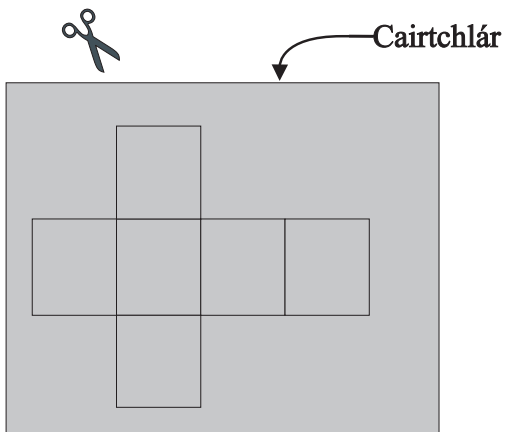

Céim 2

Fill ar feadh na línte poncaithe é.

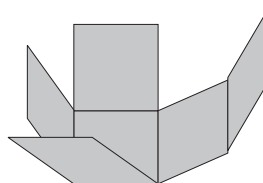

Céim 3

Greamaigh le seiliteip é.

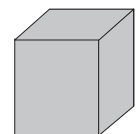

Tá teimpléid nó líontáin do chruthanna 3-T i ndeireadh an leabhair.
Gearr amach na teimpléid. Fill ar feadh na línte poncailte iad féachaint
an féidir leat cruthanna 3-T a dhéanamh. Greamaigh le seiliteip iad.

Anseo thíos tá líontáin bheaga de chruthanna 3-T. **Ná gearr** iad seo amach.

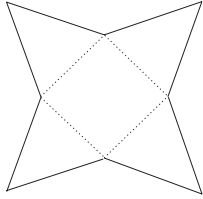

Pirimid Chearnógach

Bun cearnógach atá fúithi.

Tá ceithre aghaidh thriantánacha aici.

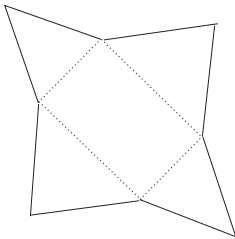

Pirimid Dhronuilleogach

Cruth dronuilleoige atá ar an mbun.

Tá ceithre aghaidh thriantánacha aici.

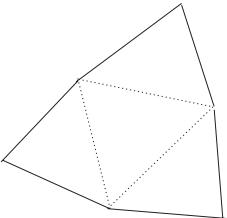

Teitrihéadrán

Ceithre aghaidh.

Triantán is ea gach aghaidh.

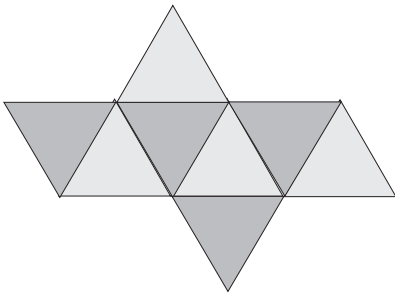

Ochtaihéadrán

Cruth 3-T agus ocht n-aghaidh air.

Triantán is ea gach aghaidh.

Dhá phirimid chearnógacha (agus ceann acu bun os cionn) atá san ochtaihéadrán.



Slánuimhir agus codán curtha leis
atá in uimhir mheasctha, e.g. $2\frac{3}{4}$

Cruth 3-T is ea **priosma**.

Bíonn an dá fhoirceann cothrom agus comhthreomhar lena chéile.



Priosma Triantánach

Bíonn an dá fhoirceann cothrom, comhthreomhar agus triantánach.

Sampla de phriosma triantánach is ea pacáiste *Toblerone*.

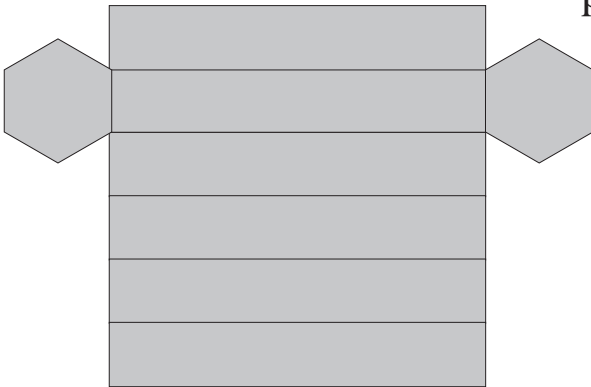

Priosma Heicseagánach

Bíonn an dá fhoirceann cothrom, comhthreomhar agus heicseagánach.



Priosma Peinteagánach

Dhá fhoirceann chothroma aige, iad comhthreomhar agus peinteagánach.

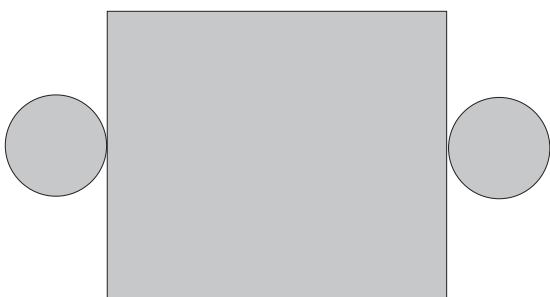

Sorcóir

Bíonn dhá fhoirceann chiorclacha aige, iad cothrom agus comhthreomhar.

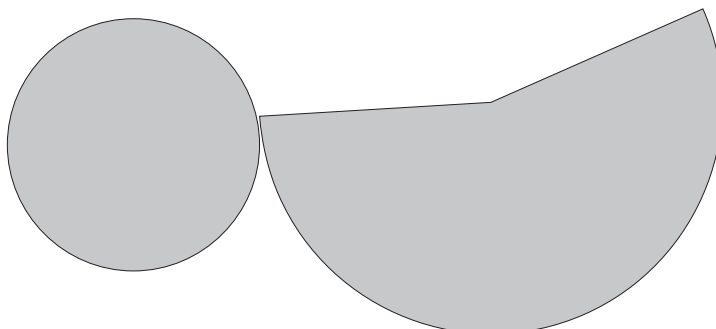

Cón

Bíonn bonn chiorclach faoi agus stuaic nó rinn amháin air.

Sampla de chón oscailte is ea cón uachtair reoite.

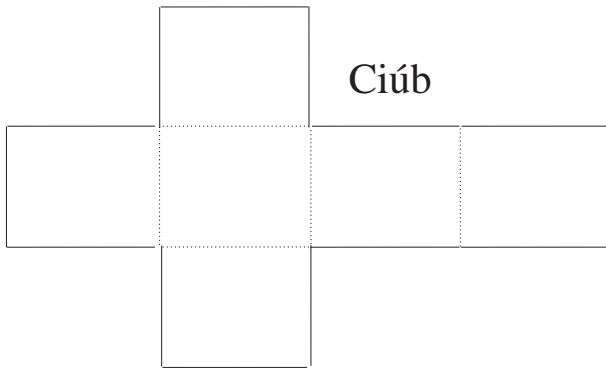

Ciúb

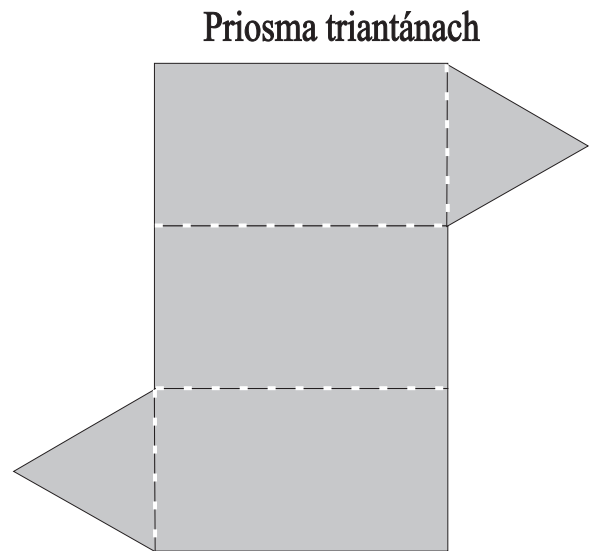

Priosma triantánach

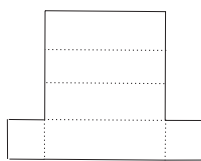

Ciúbóideach

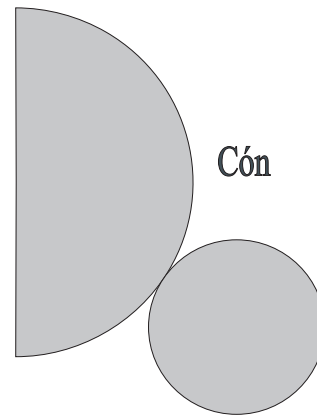

Cón

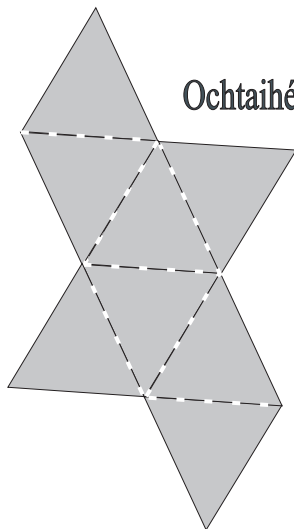

Ochtaihéadrán

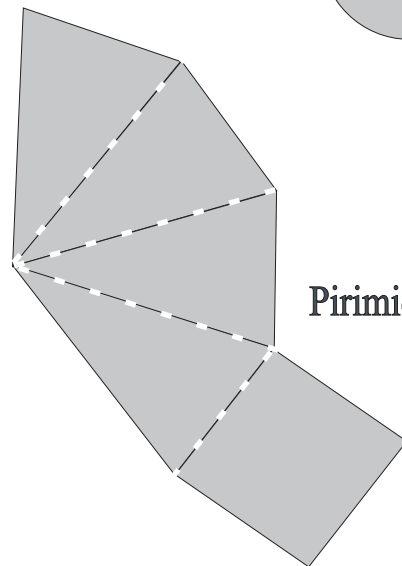

Pirimid

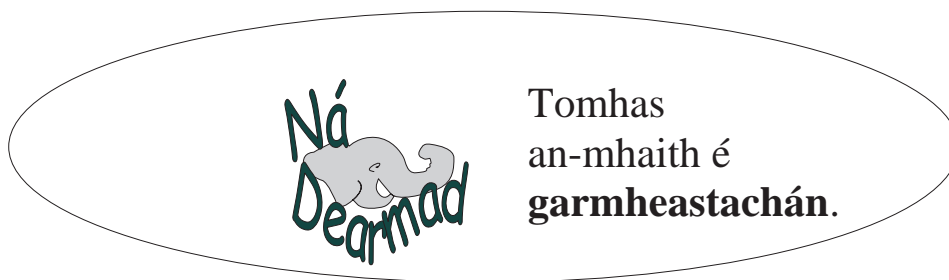

Abairtí Matamaiticiúla

Siombail	An Bhrí
=	cothrom le
≠	níl sé cothrom le
>	níos mó ná
<	níos lú ná

Faigh luach na huimhreach atá in easnamh. Sampla:

$$\begin{aligned} \square + 7 &= 9 \\ x + 7 &= 9 \\ x &= 2 \end{aligned}$$

①

(a) $20 - \square = 12$

(b) $\square + 7 = 18$

(c) $8 \times \triangle = 20 + 12$

(d) $6 \times \square = 36 \div 3$

(e) $140 - \bigcirc = 12 \times 10$

(f) $7 \times \triangle = 49$

(g) $48 \div \bigcirc = 144 \div 12$

(h) $108 \div 9 = 132 \div \triangle$

(i) $36 + \square = 9 \times 8$

(j) $6 \times \bigcirc = 50 + 10$

(k) $12 \times \triangle = 120 \div 12$

(l) $100 + 32 = 11 \times \square$

Cothromóidí

① Déan iad seo sa tslí chéanna.

Sampla:

$$y + 4 = 6$$

Táimid ag iarraidh teacht ar an bhfreagra $y = \square$

Cuir -4 leis an **dá** thaobh, agus faigh réidh leis an 4 .

$$\text{Mar sin } y + 4 - 4 = 6 - 4$$

$$y = 2$$

Is féidir an freagra a thástáil ach luach y a chur sa chéad chothromóid thuas.

(a) $x + 8 = 19$

(b) $a + 12 = 27$

(c) $b - 17 = 6$

(d) $x - 9 = 34$

(e) $y - 14 = 29$

(f) $x + 7 = 25$

Faigh luach x

②

(a) $2x + 1 = 27$

(b) $3x - 5 = 7$

(c) $4x - 12 = 0$

(d) $5x = 2\frac{1}{2}$

(e) $4(1 + x) = 36$

③

(a) $2x = 3.85$

(b) $0.2y + 1.5 = 2.2$

(c) $a - 12 = 18$

(d) $25 = a - 8$

(e) $x + 23 = 38$



Uimhir dhronuilleogach í uimhir ilchodach.

Seans



Seans maith go mbeidh sé ag cur ar do lá breithe más i mí Aibreáin a rugadh tú. An-seans nach mbeidh sé ag cur más i lár mhí Iúil a bhíonn do lá breithe. Más sa Sahára atá cónaí ort, bhuel is ar éigin a bheidh sé fliuch – cé go bhfuil an seans ann i gcónaí!



Má chaitheann tú bonn san aer tá an seans céanna ann gur ar a ghaidh nó ar a chúl a thitfidh sé.

Abair go raibh dhá chiúb i mála. Tá dath bán ar chiúb amháin díobh agus dath dubh ar an gceann eile. Má phiocann tú ciúb amháin go randamach as an mála tá an seans céanna agat an ciúb bán nó an ciúb dubh a phiocadh. D'fhéadfaí a rá gur seans 'caoga-caoga' atá ann go bpiocfá an ciúb bán.

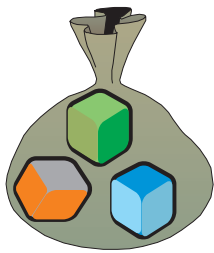

Abair go raibh trí chiúb daite i mála – ceann dearg, ceann glas agus ceann gorm. Cé acu dath is dóichí a phiocfá go randamach, gan breathnú sa mhála roimh ré?

Freagra: Tá an seans céanna ag gach dath. Níl seans níos fearr ag dath amháin seachas a chéile

Cé mhéad toradh féideartha atá ann?

Freagra: Trí thoradh fhéideartha.

Cé mhéad toradh atá ann don ghorm?

Freagra: Ceann amháin as trí cinn. (1 as 3)

Cén seans atá ann gurb é an ciúb gorm a phiocfá amach?

Freagra: 1 as 3

Is féidir a rá go bhfuil seans amháin ann as 3 cinn gur dath gorm a bheidh ar an gciúb.

Má chuirimid an téarma 'dóchúlacht' in áit 'seans', is féidir a leithéid seo a leanas a scríobh

“Tá dóchúlacht 1 as 3 leis an dath gorm.”

An bhfuil seans níos mó ann nach é an gorm a phiocfaí?

Smaoinigh arís ar na torthaí féideartha ar fad.

Tá a fhios againn go bhfuil 3 thoradh éagsúla is féidir a bheith ann, agus nach é an dath gorm a bheadh i gceist i gcás dhá thoradh díobh.

- ① Caith bonn san aer ocht n-uaire as a chéile agus scríobh cuntas ar na torthaí sa tábla seo.

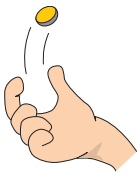

	Toradh	
	Aghaidh	Cúl
1ú caitheamh		
2ú caitheamh		
3ú caitheamh		
4ú caitheamh		
5ú caitheamh		
6ú caitheamh		
7ú caitheamh		
8ú caitheamh		
Iomlán:		

B'fhéidir go raibh tú ag súil le 4 aghaidh agus 4 chúl. Dá mhéad a dhéanann tú é is ea is mó seans gur torthaí cothroma a gheobhaidh tú.

D'fhéadfá ocht gcúl as a chéile a fháil ach níl ann ach caolseans.

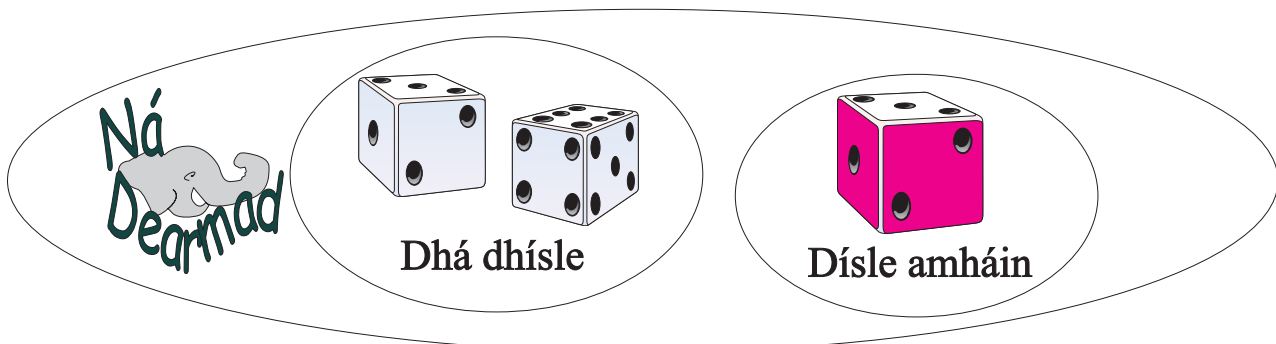

Déan roithleán as píosa cairtchláir agus lasán solais.

① Cén dóchúlacht atá ann go bhfaighfeá 1?

Cén dóchúlacht atá ann go bhfaighfeá 2?

Cén dóchúlacht atá ann go bhfaighfeá 6?

Bain triail as. Coinnigh taifead ar an toradh ar 24 rothlú.

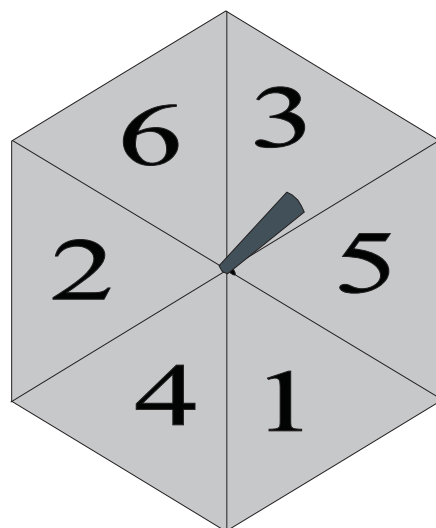

②

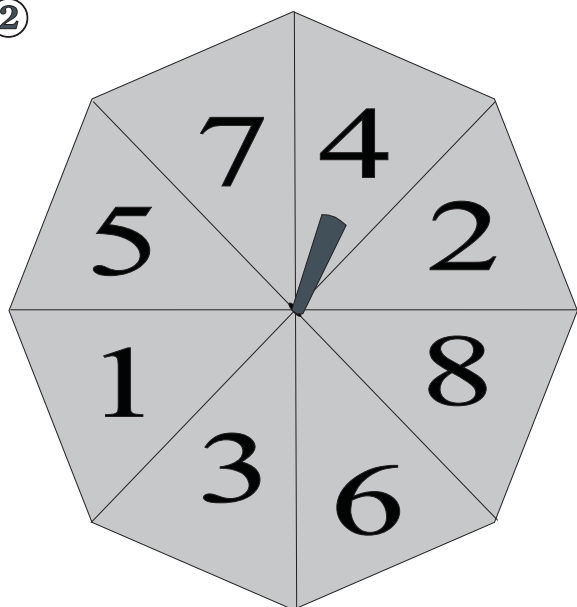

Cén dóchúlacht atá ann go bhfaighfeá 1?

Cén dóchúlacht atá ann go bhfaighfeá 5?

Cén dóchúlacht atá ann go bhfaighfeá 8?

Bain triail as. Coinnigh taifead ar an toradh ar 32 rothlú.

③

Cé acu toradh is dóichí ar an roithleán seo, ré-uimhir nó corruimhir?

Cén dóchúlacht atá ann go bhfaighfeá ré-uimhir?

Cén dóchúlacht atá ann go bhfaighfeá corruimhir?

Bain triail as. Coinnigh taifead ar an toradh ar 20 rothlú.

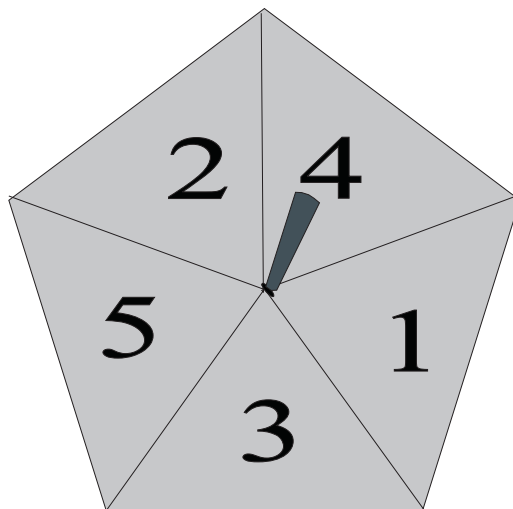

Má chaitheann tú dhá bhonn san aer cén dóchúlacht atá ann gur dhá aghaidh an toradh? Smaoinigh ar na ceisteanna seo a leanas sula dtuga tú freagra:

Cé mhéad toradh féideartha atá ann?







Cé mhéad toradh a thabharfadh dhá aghaidh?

Tá an freagra ar an dara ceist éasca go maith. Níl ach aon toradh amháin a thugann dhá aghaidh.

Torthaí

Breathnaímis ar na torthaí féideartha éagsúla.

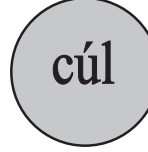
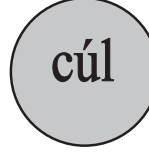
An Chéad bhonn **An Dara bonn**

Cúl an chéad bhonn agus aghaidh an dara bonn. Toradh: 1 aghaidh agus 1 cúl.		
Aghaidh an chéad bhonn agus cúl an dara bonn Toradh: 1 aghaidh agus 1 cúl		
Cúl an chéad bhonn agus cúl an dara bonn. Toradh: 2 cúl		
Aghaidh an chéad bhonn agus aghaidh an dara bonn. Toradh: 2 aghaidh		

4 thoradh féideartha atá ann. Níl aon toradh eile is féidir a bheith air.

Níl ach toradh amháin ann a thugann dhá aghaidh agus tá ceithre thoradh fhéideartha ann san iomlán. Deirimid go bhfuil dóchúlacht 1 as 4 ann le dhá aghaidh a fháil as dhá chaitheamh san aer.

Cén dóchúlacht atá ann le cúl amháin agus aghaidh amháin a fháil? (Is cuma faoin ord.) Smaoinigh, cé mhéad uair a fuair tú aghaidh amháin agus cúl amháin mar thoradh? Tá sé le sonrú ar na torthaí thuas go bhfuil dhá thoradh a thabharfadh aghaidh amháin agus cúl amháin. Ceithre thoradh fhéideartha atá ann. Deirimid go bhfuil dóchúlacht 2 as 4 ann le cúl amháin agus aghaidh amháin as dhá chaitheamh san aer.

Fadhbanna

①

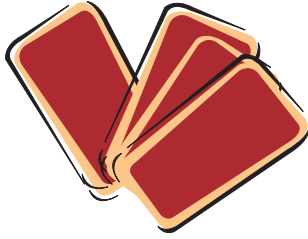

Tá ceithre cárta ina luí béal faoi ar an mbord – hairt, triuf, spéireata agus muileata. Má phiocaim suas cárta amháin, cén dóchúlacht atá ann le spéireata a fháil?

②



Má rothlaím díisle cén dóchúlacht atá ann le 4 a fháil?

③

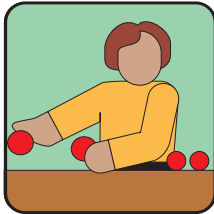

Abair go raibh 250 uaireadóir i mbosca a seachadadh chugam agus go raibh ceann amháin díobh lochtach. Cén dóchúlacht atá ann gurb é an t-uaireadóir lochtach a phiocfaidh mé má bhainim aon uaireadóir amháin as an mbosca? An ndéarfá go raibh seans maith ann gurbh é an t-uaireadóir lochtach a phiocfainn amach in aon iarracht randamach amháin?

④



Má phiocann tú cárta go randamach as paca cén dóchúlacht atá ann gurb é an t-aon triuf a phiocfaidh tú?

⑤

Cén dóchúlacht atá ann le huimhir níos mó ná 6 a phiocadh as {3, 4, 5, 6, 7, 9}?

⑥



Má rothlaím díisle uair amháin cén dóchúlacht atá ann gur ré-uimhir a gheobhaidh mé?

26 litir atá in
aibítir an Bhéarla

①

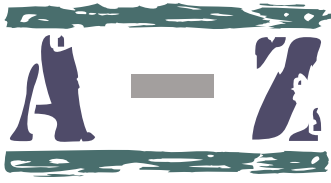

Tá bosca 26 cárta agam agus litir
den aibítir ar gach cárta ar leith.

Má phiocann tusa cárta amháin amach
go randamach cén dóchúlacht atá ann
gurb í an litir **D** a phiocfaidh tú?

② Cé mhéad guta atá san aibítir?



③ Cén dóchúlacht atá ann gur guta a phiocfaidh tú?

④ Cé mhéad consan atá san aibítir?

⑤ Cén dóchúlacht atá ann gur consan a phiocfaidh tú?

⑥ Cé acu is dóichí – gur guta nó consan a phiocfaidh tú?

⑦



Má rothlaíonn tú díse, an mó seans gur 1 seachas 2
a gheobhaidh tú?

⑧



Tá 12 bhuachaill agus 13 chailín i seomra ranga.
Imríonn beirt chailíní agus ochtar buachaillí peil.
Má phiocaim dalta amháin go randamach cén seans
atá ann go n-imríonn an dalta sin peil?

Ciúb

Cóipeáil an cruth seo ar leathanach cairtchláir.
Féach na treoracha ar Leathanach 22 - 3.

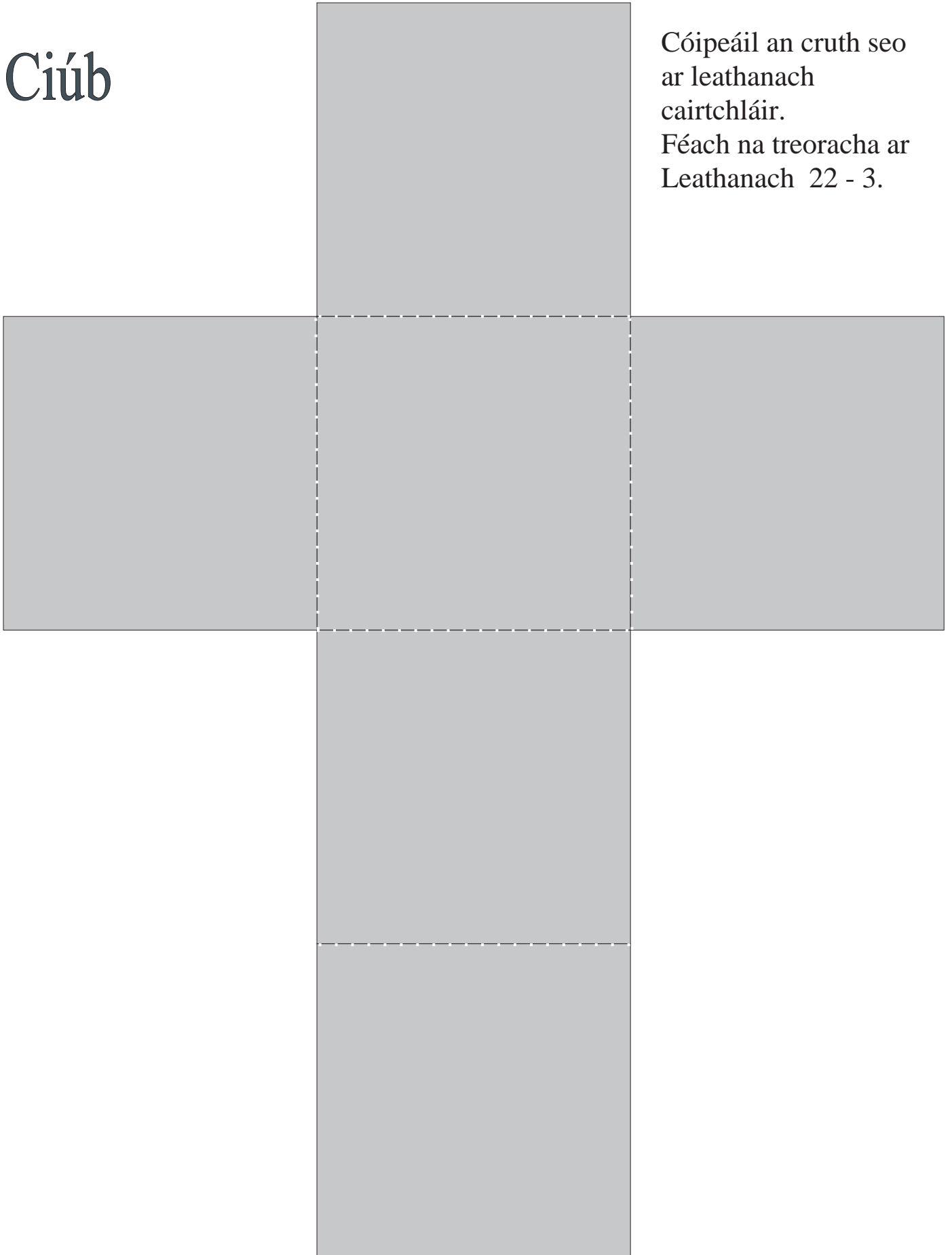

Ciúb

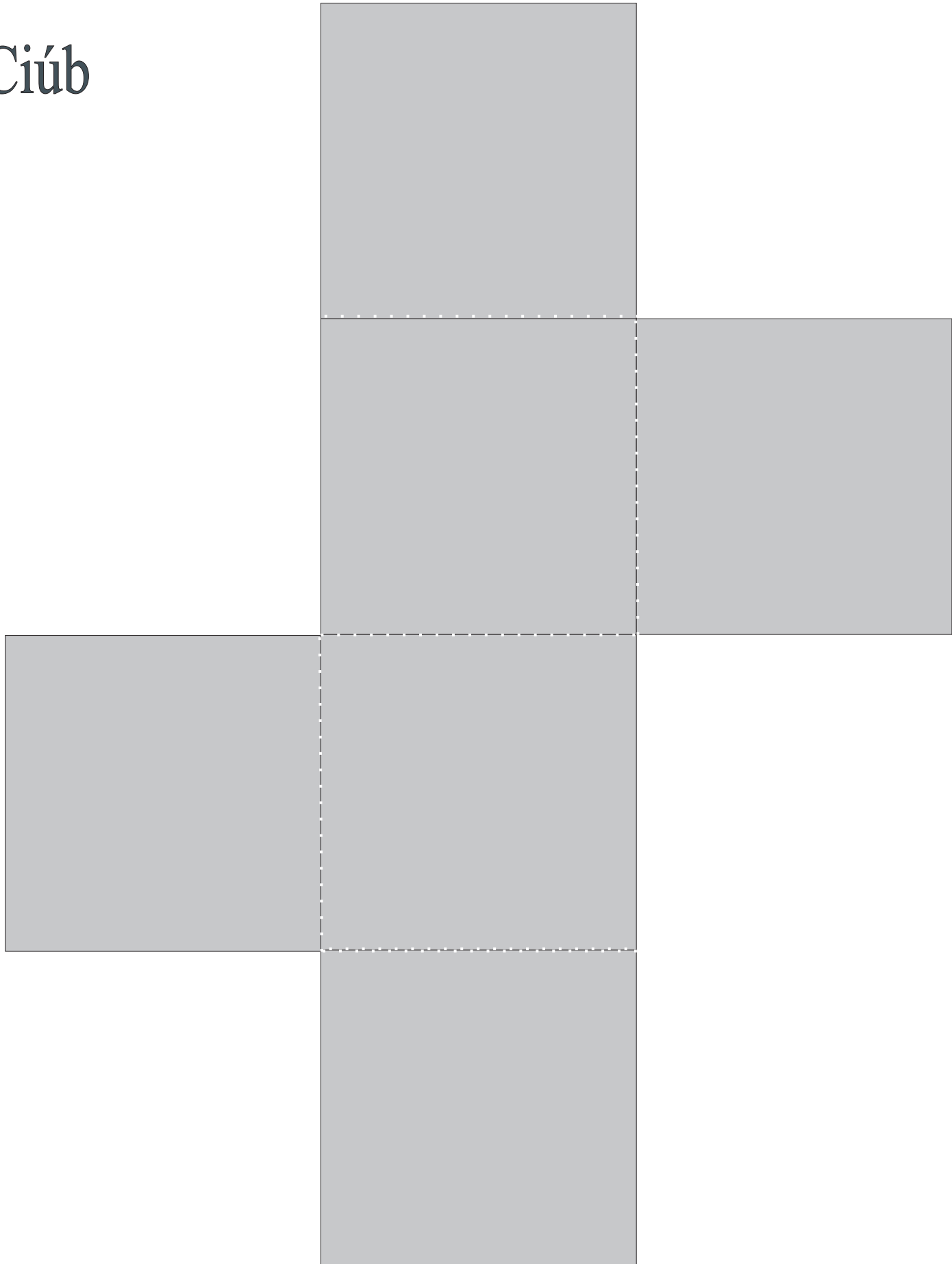

Ciúbóideach

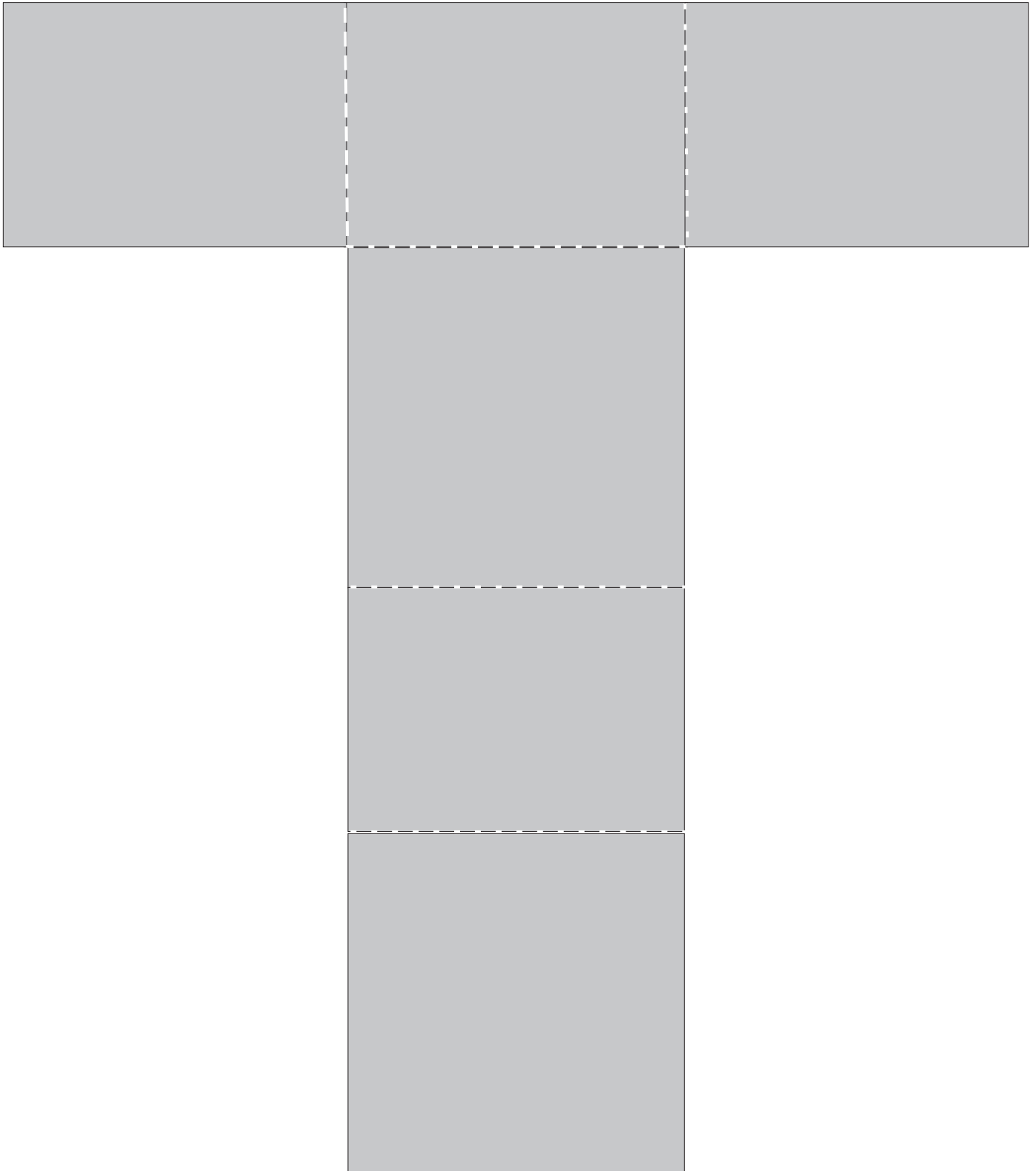

Priosma (triantánach)

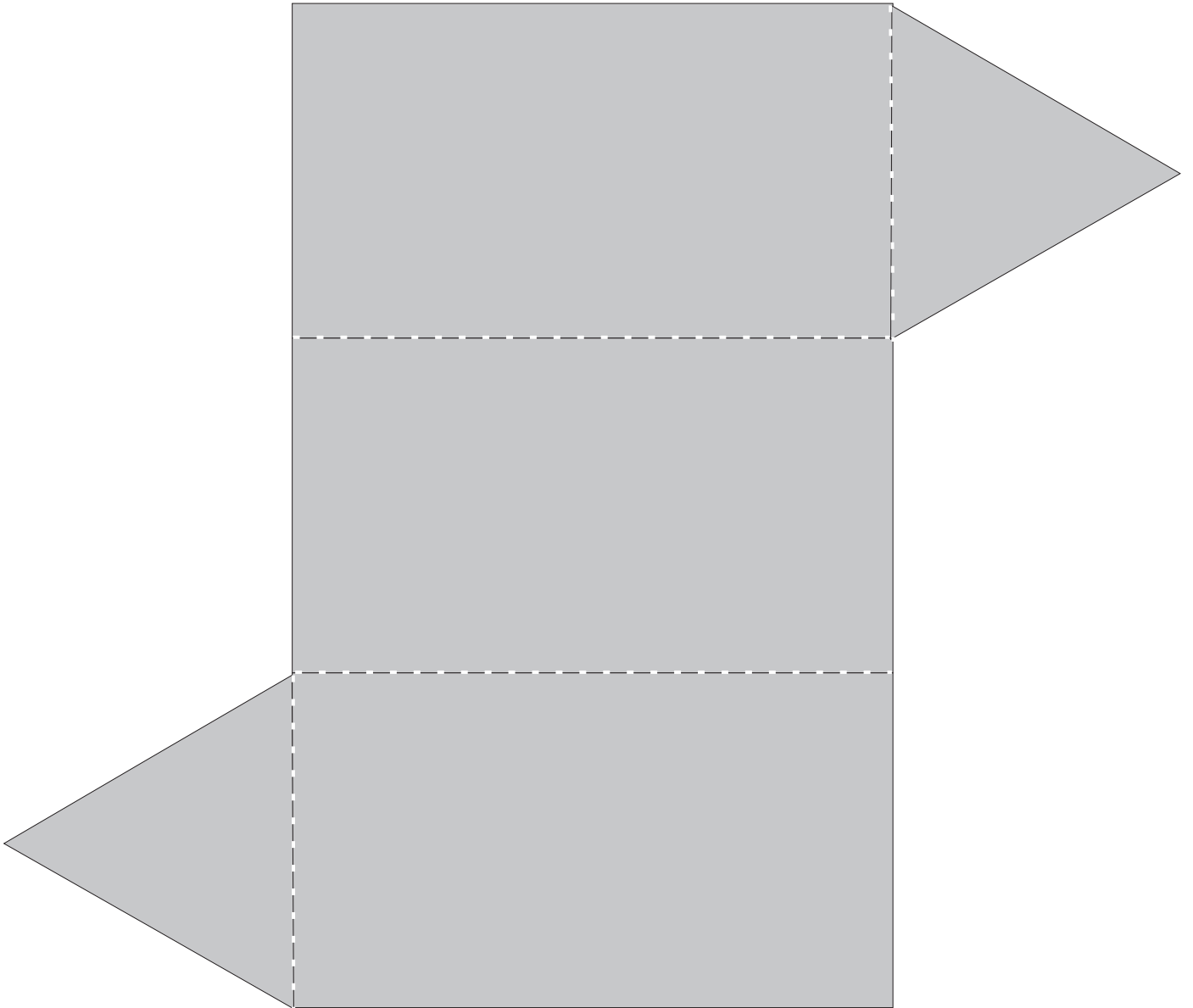

Priosma (triantánach)

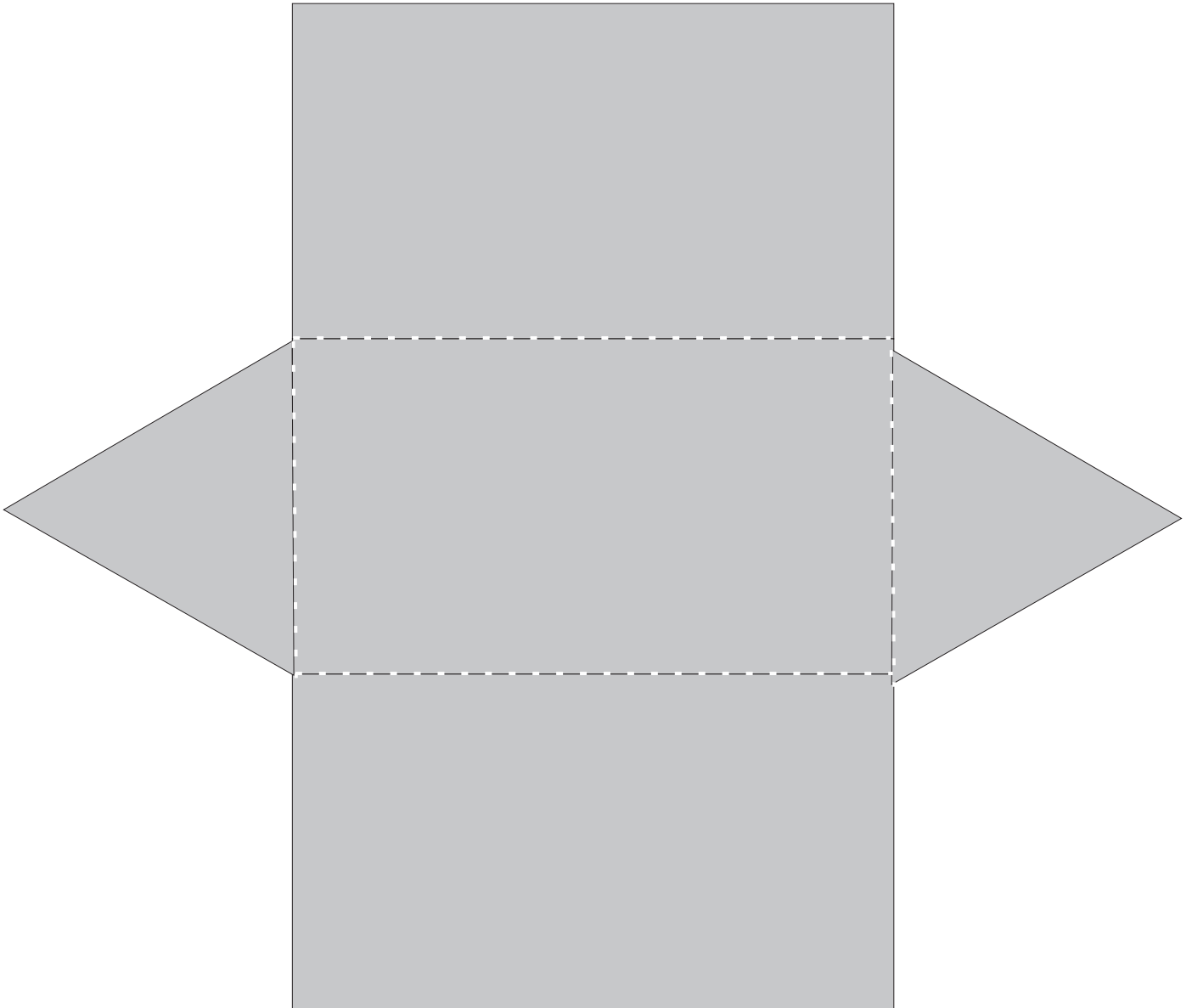

Teitrihéadrán

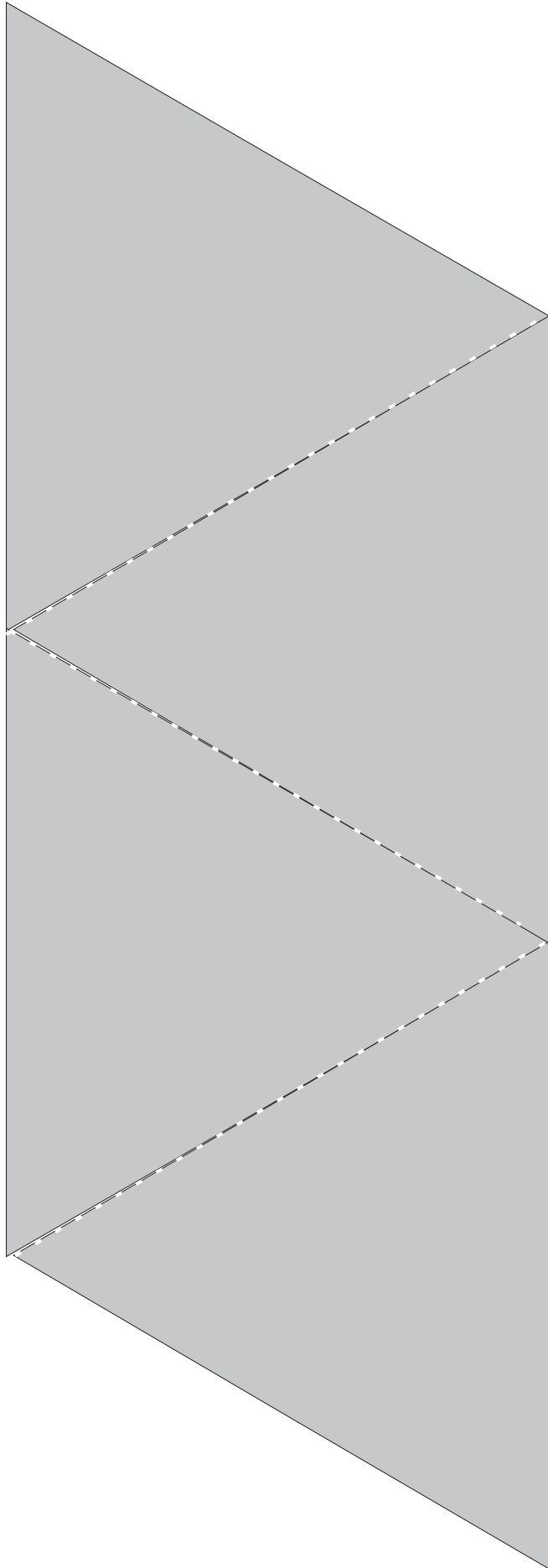

Pirimid

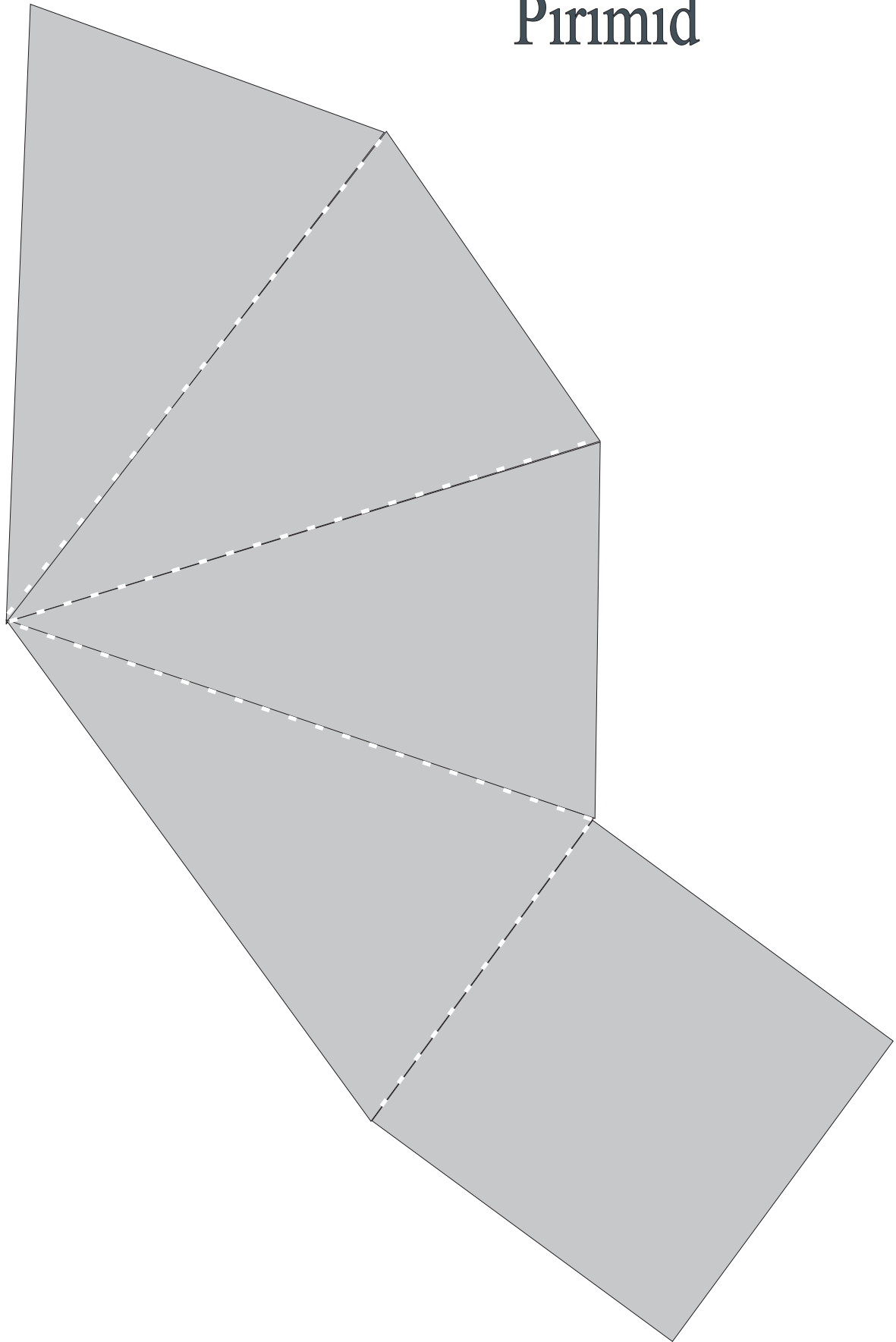

Pirimid

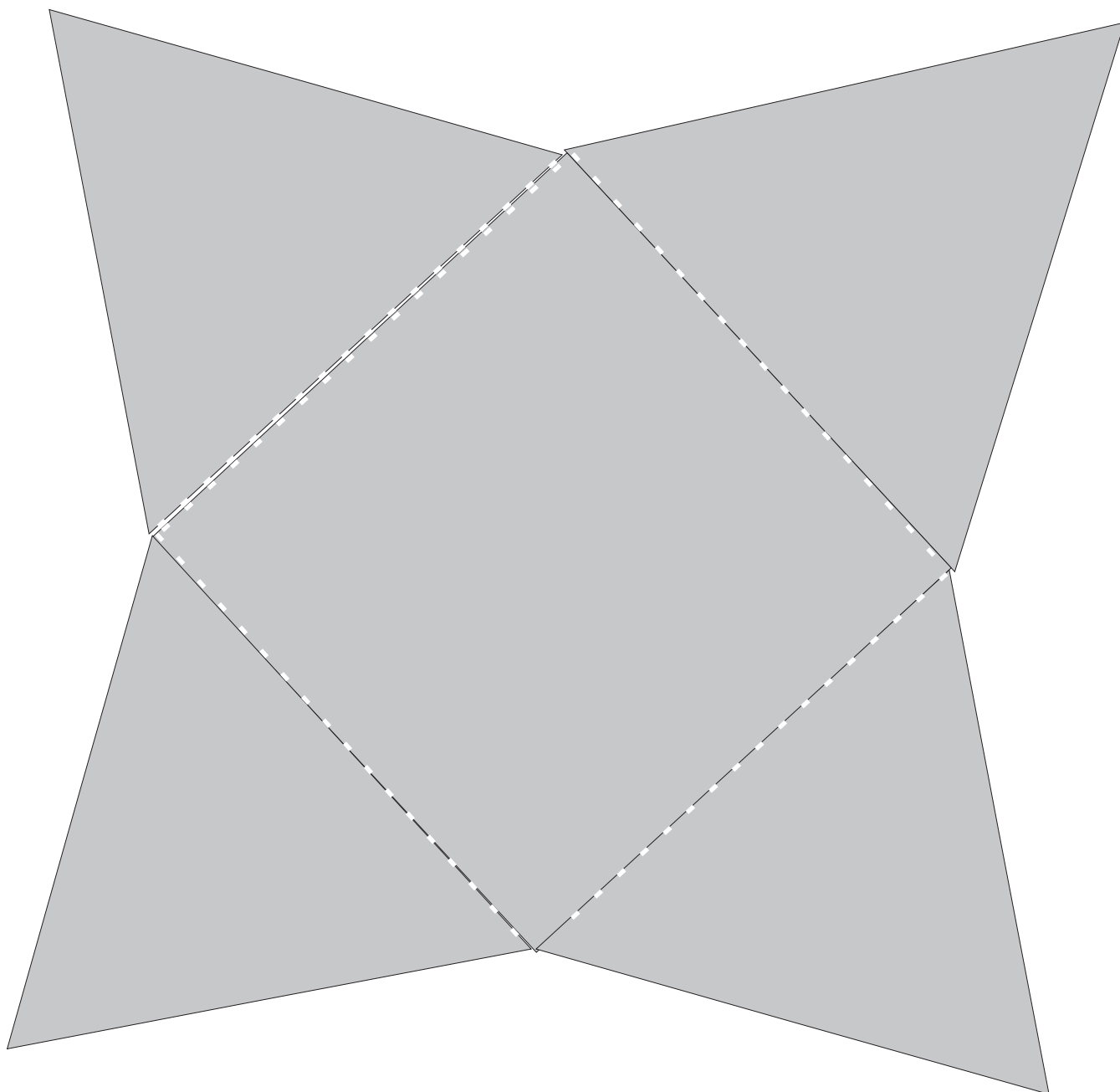

Priosma (peinteagánach)

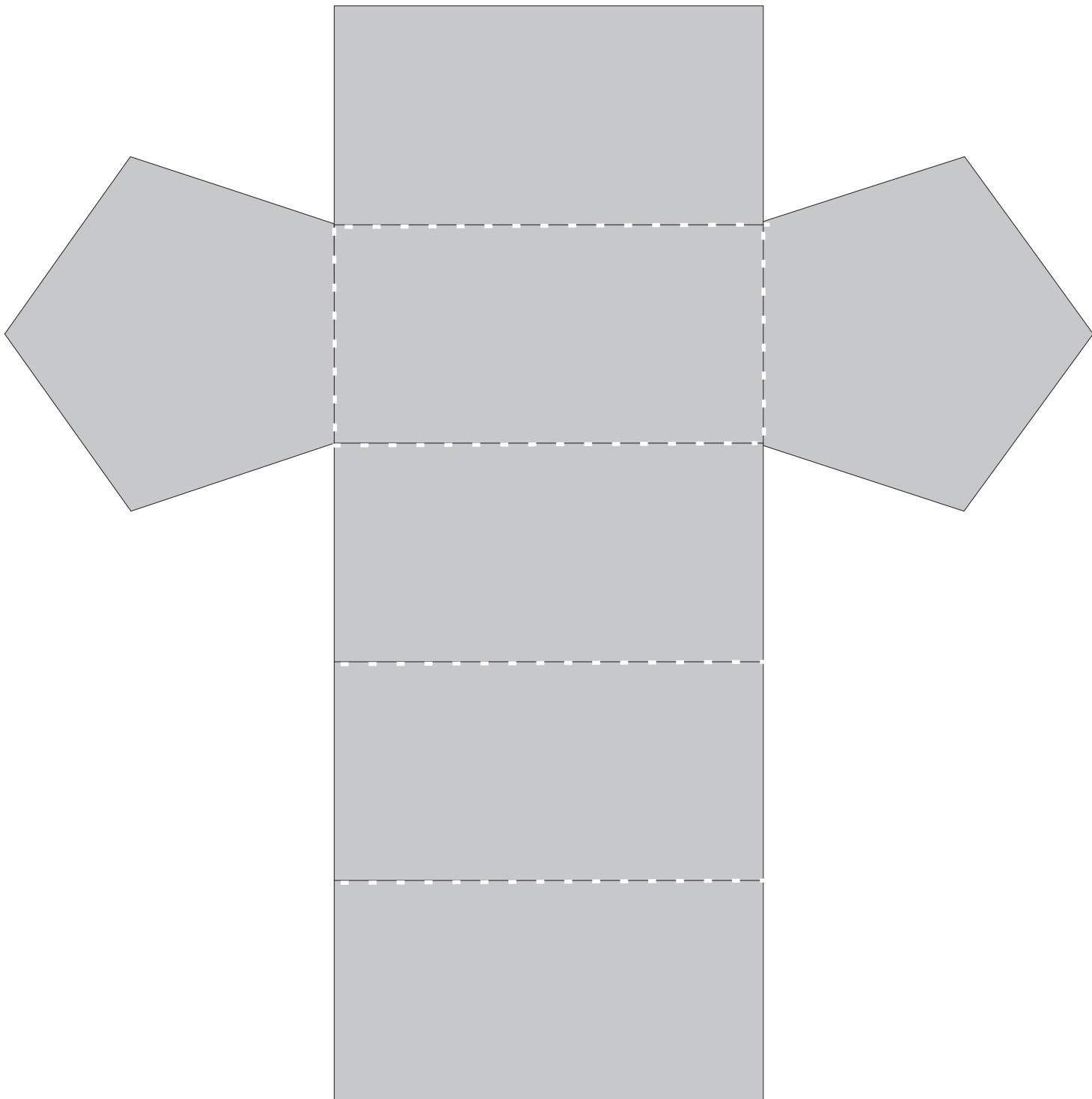

Priosma (heicseagánach)

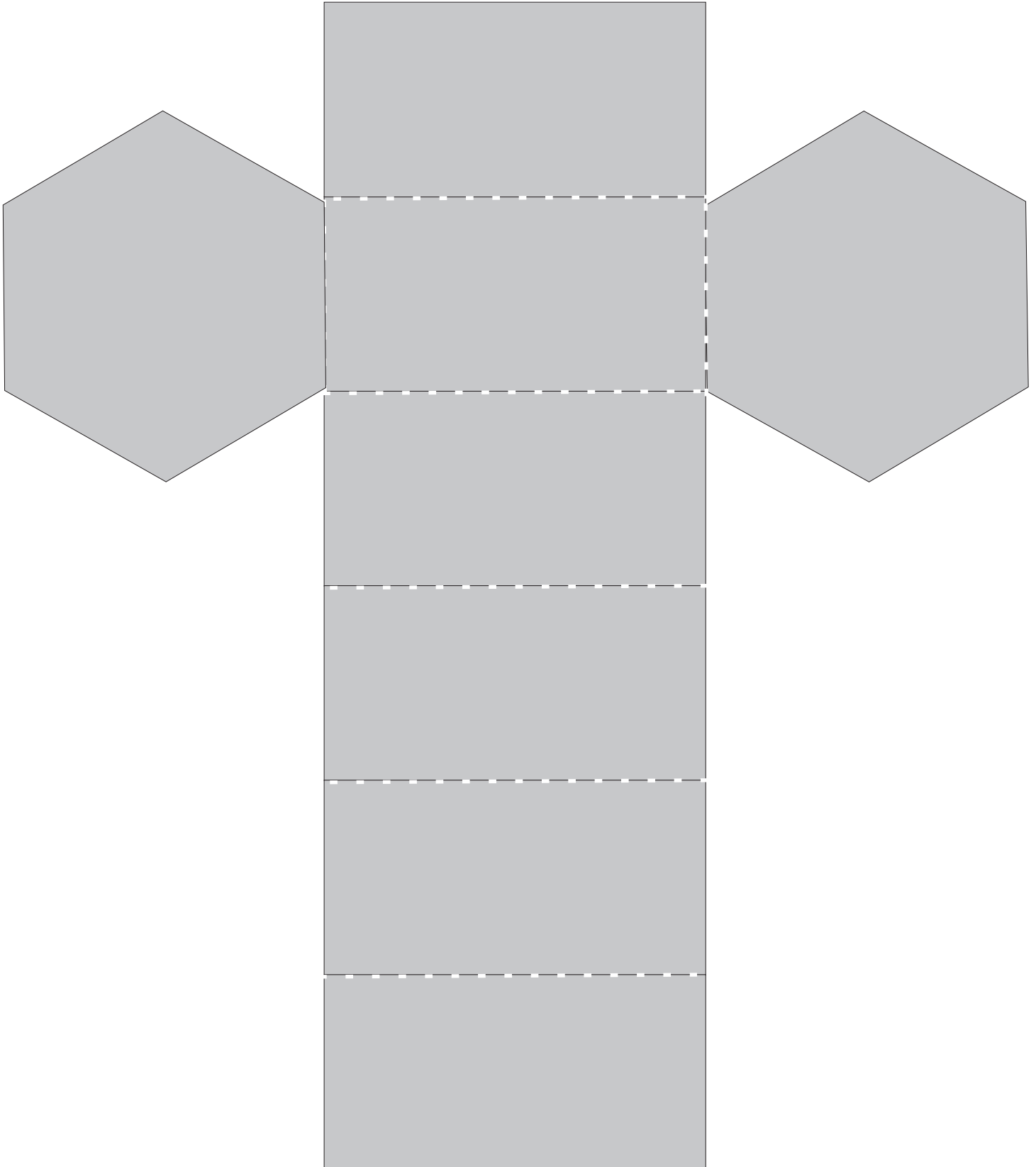

Sorcóir

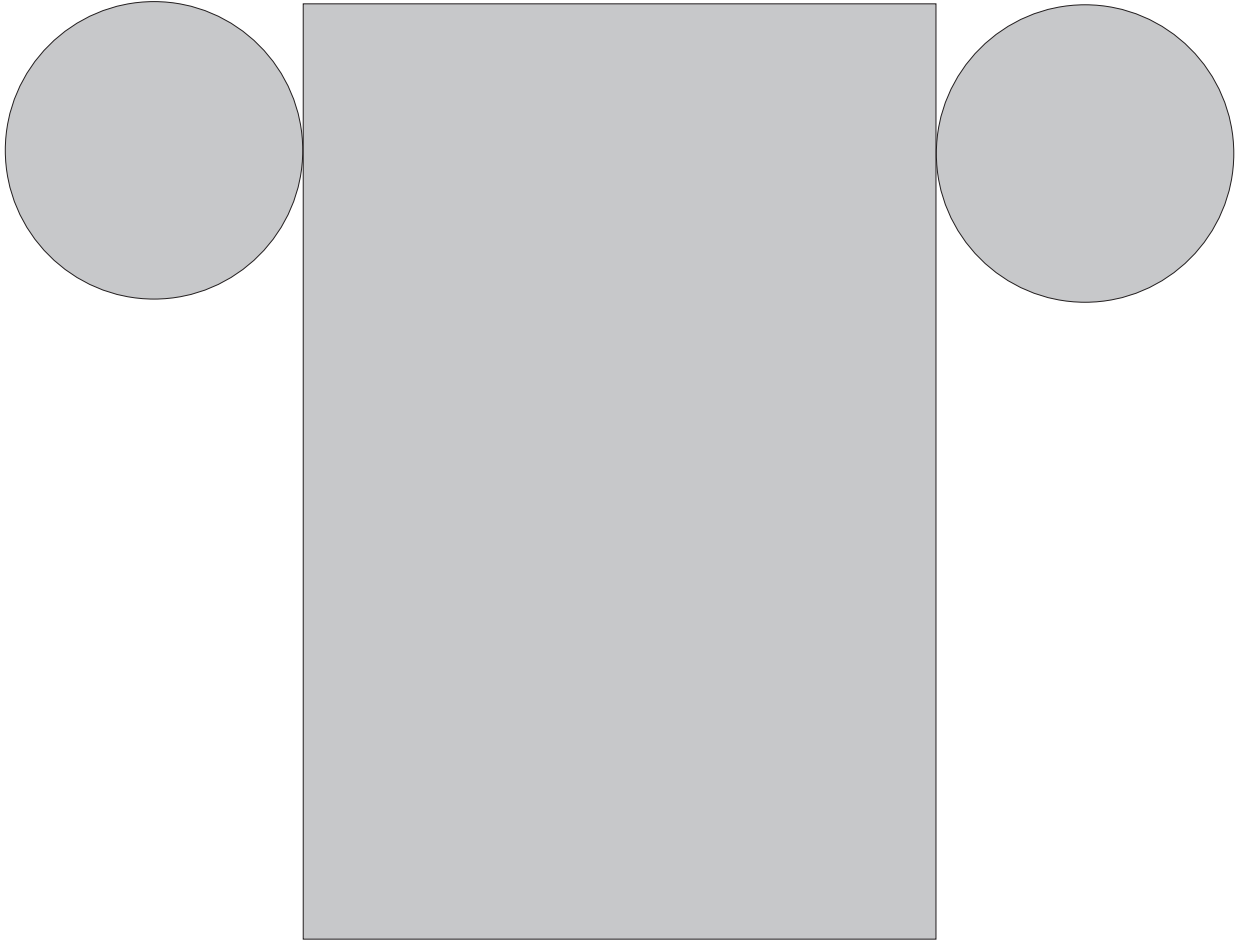

Ochtaihéadrán

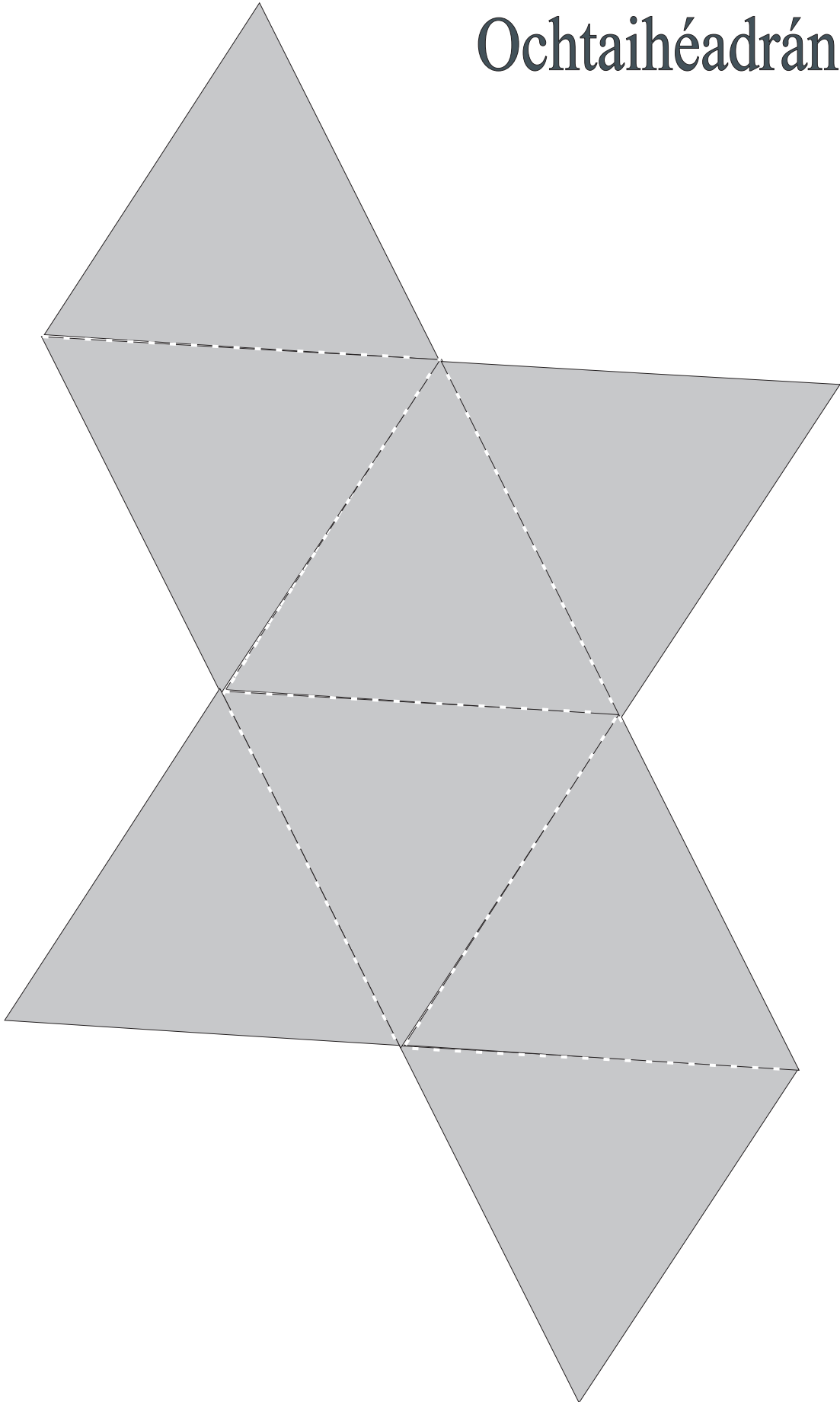

Cón

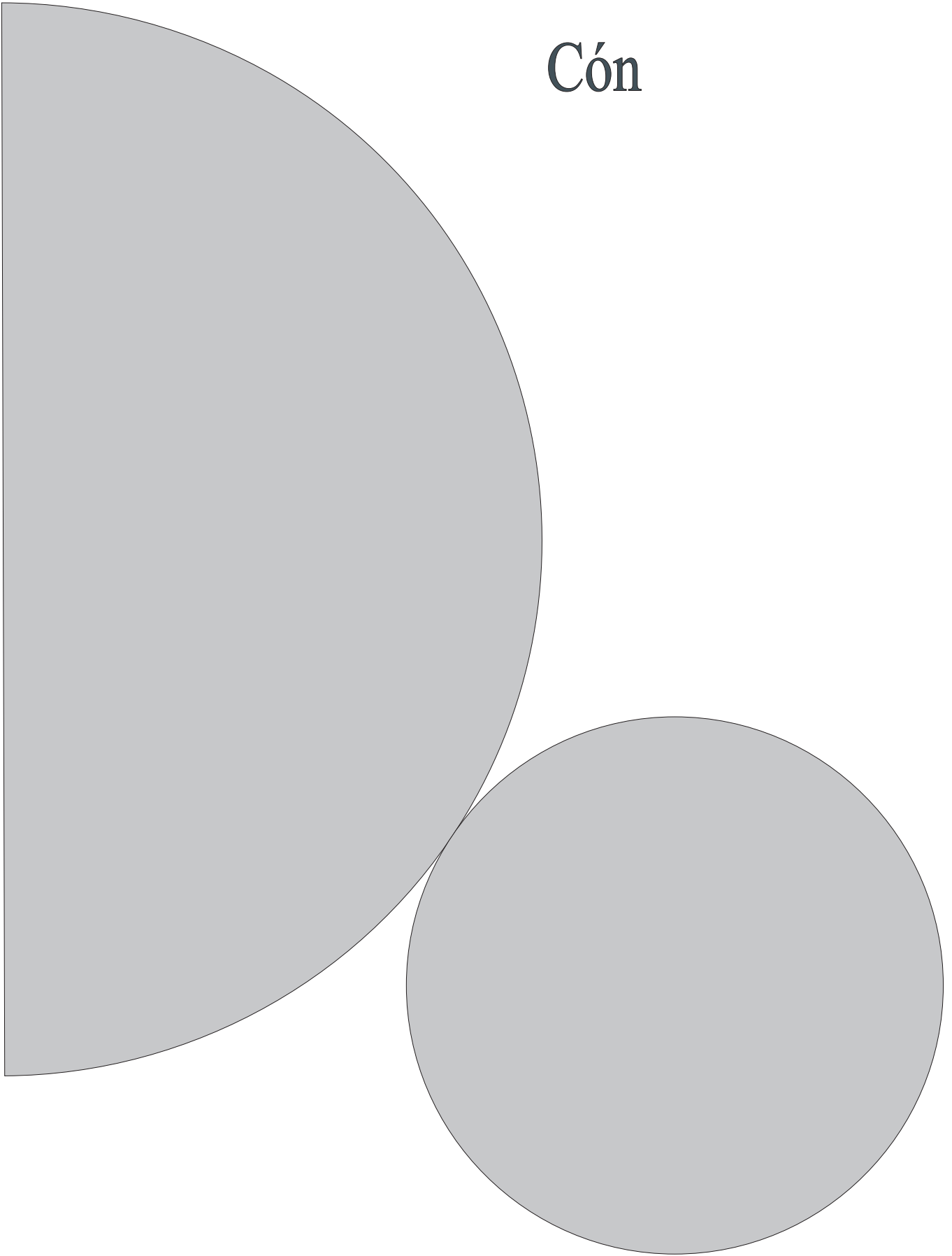

1

(A) $3745 + 4692 + 1479 + 2564 =$

(B) $964 + 77 + 1598 + 3978 =$

(C) $845 + 6547 + 2179 - 3596 =$

(D) $34.75 + 3.91 + 18.05 + 4.65 =$

(E) $0.07 + 49.29 + 17.65 + 39 =$

(F) $54.6 \times 7 =$

(G) $33.27 \times 10 =$

(H) $509.73 \times 28 =$

(I) $56.354 \times 100 =$

(J) $48.16 \times 40 =$

Obair Gharbh

2

(A) $3.6 \times 45 =$

(B) $38 \times 5.2 =$

(C) $27 \times 7.3 =$

(D) $78 \times 8.6 =$

(E) $50.6 \times 0.9 =$

(F) $47.5 \times 0.53 =$

(G) $7.62 \times 4.61 =$

(H) $5.47 \times 7.64 =$

(I) $52.38 \times 60 =$

(J) $488.7 \times 10 =$

Obair Gharbh

3

(A) $92.4 \div 7 =$

(B) $5.598 \div 2 =$

(C) $3.584 \div 4 =$

(D) $5.802 \div \square = 0.967$

(E) $4.376 \div \square = 0.547$

(F) $3.52 \div 80 =$

(G) $4.56 \div 60 =$

(H) $4.03 \div 0.13 =$

(I) $66.3 \div 3.9 =$

(J) $507.3 \div 0.57 =$

Obair Gharbh

4

Corruimhir nó Ré-uimhir?

Obair Gharbh

A

15

21

23

12

B

corruimhir + corruimhir =

C

corruimhir + ré-uimhir =

Scríobh na chéad trí théarma eile sna seichimh uimhreacha thíos.

D

$\frac{3}{4}$, $2\frac{1}{4}$, $3\frac{3}{4}$, $5\frac{1}{4}$

E

3·9, 5·1, 6·3, 7·5

F

Cuir ciorcal timpeall ar na huimhreacha príomha.

1, 6, 7, 9, 11, 14

G

Cad iad na chéad cheithre uimhir thriantánacha?

H

Fíor nó Bréagach?

Uimhir chearnógach í 9.

Uimhir dhronuilleogach í 12.

5

Obair Gharbh

- (A) Faigh fachtóir coiteann is airde (FCA)
na n-uimhreacha seo:

30, 45, 54, 72

- (B) Faigh iolraí coiteann is lú (ICL)
na n-uimhreacha seo:

3, 7, 12, 8

Líon isteach na boscaí.

(C) $\frac{1}{2} = \frac{\square}{8}$

(D) $\frac{1}{2} + \frac{1}{8} = \frac{\square}{8}$

(E) $1 - \frac{1}{4} = \frac{\square}{4}$

(F) $\frac{1}{3} + \frac{2}{6} = \frac{\square}{3}$

(G) $\frac{3}{3} = \frac{\square}{6}$

(H) $\frac{1}{2} = \frac{\square}{6}$

(I) $1 - \frac{7}{8} = \frac{\square}{\square}$

(J) $\frac{1}{2} = \frac{\square}{10}$

6

Féach ar an **gcuid** seo den uimhirlíne.
An féidir leat na leaschodáin a scríobh isteach ag na marcanna?

A

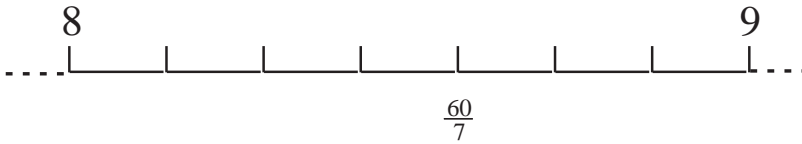

B

Cén codán atá scáthaithe?

$\frac{33}{6}$, $\frac{3}{3}$, $\frac{1}{3}$, $\frac{6}{9}$

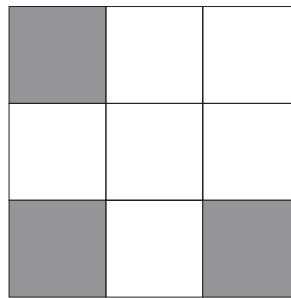

C

$$\frac{\square}{10} = \frac{5}{50}$$

D

$$\frac{7}{\square} = \frac{21}{24}$$

E

Cuir ciorcal timpeall ar na huimhreacha measctha.

$\frac{1}{4}$, $3\frac{1}{4}$, $4\frac{1}{7}$, $\frac{1}{5}$, $\frac{1}{4}$, $\frac{1}{10}$

F

Cuir ciorcal timpeall ar na leaschodáin.

$\frac{3}{2}$, $\frac{10}{5}$, $\frac{1}{100}$, $\frac{1}{20}$, $\frac{6}{5}$

7

Ⓐ $2\frac{1}{4} + 3\frac{1}{6} =$

Ⓑ $4\frac{1}{3} + 2\frac{1}{5} =$

Ⓒ $4\frac{3}{8} - \frac{15}{16} =$

Ⓓ $4\frac{1}{4} + 5\frac{2}{3} - \frac{1}{2} =$

Ⓔ $5\frac{1}{5} \times 7\frac{1}{2} =$

Ⓕ $\frac{1}{2} \text{ de } 8\frac{3}{4} =$

Ⓖ $9\frac{1}{3} \div \frac{4}{5} =$

Ⓗ $5\frac{3}{4} \div \frac{1}{8} =$

Ⓘ $\frac{1}{4} \text{ de } 392 =$

Ⓙ $\frac{1}{10} \text{ de } 280 =$

Obair Gharbh

Obair Gharbh

8

Cén codán de na cruthanna seo atá scáthaithe?

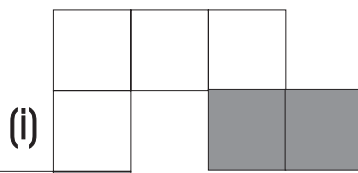

A

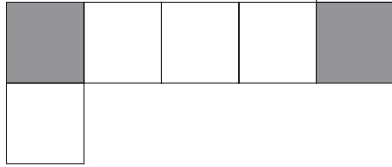

(ii)



(iii)

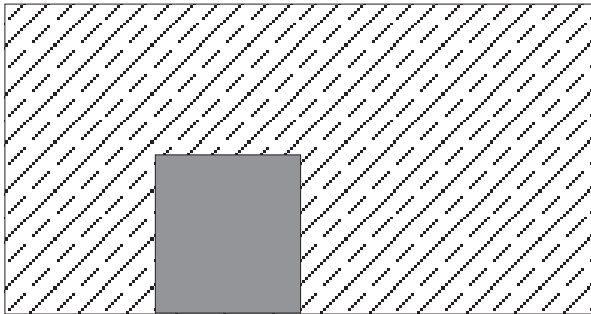

B

Faigh an t-achar.

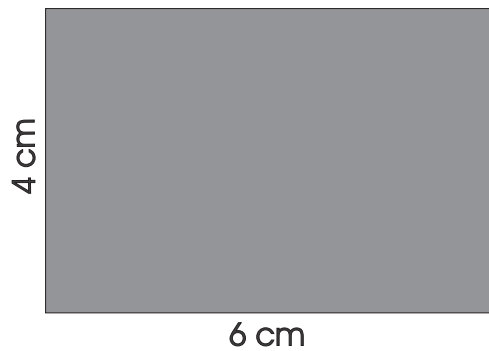

C

Faigh an leithead.

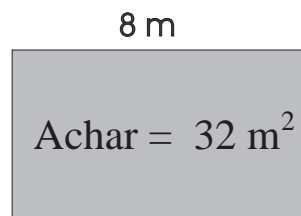

D

Faigh imlíne na dronuilleoige. 12 cm



9

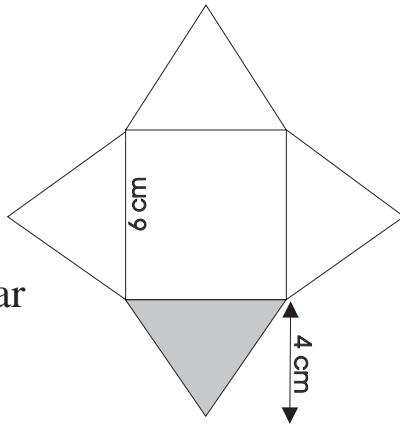

A Faigh an t-achar atá scáthaithe.

B Cé na línte atá: ceartingearach, cothrománach, comhthreomhar?

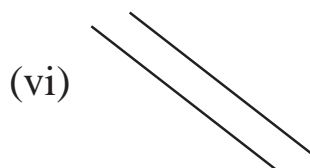
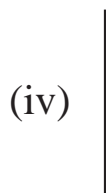
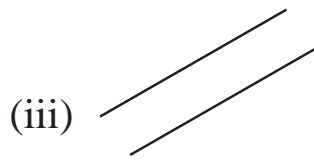
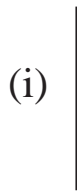

10

A

Cuir tic ✓ le gach géaruillinn.

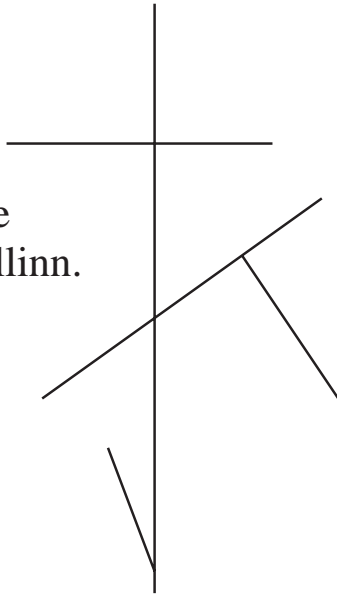

B

Ainmnigh na huillinneacha seo thíos.

(i)



(ii)

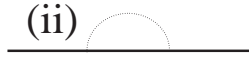

(iii)



(iv)

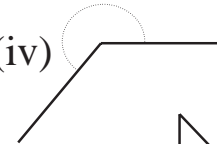

(v)



(vi)

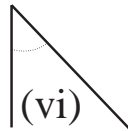

C

Ríomh luach na n-uillinneacha thíos.
Ná **húsáid** d'uillinntomhas.

(i)

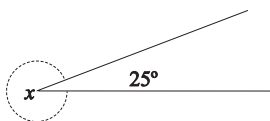

(ii)

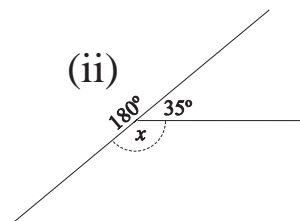

Obair Gharbh

11

Ríomh luach na n-uillinneacha thíos.
Ná húsáid d'uillinntomhas.

Obair Gharbh

A

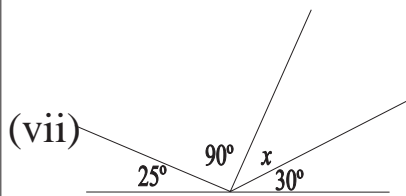
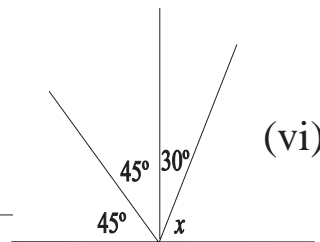
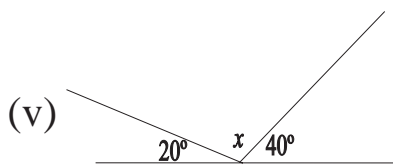
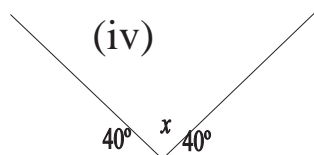
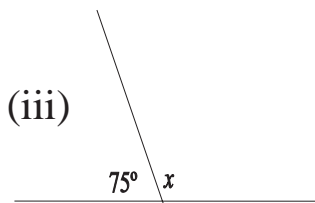
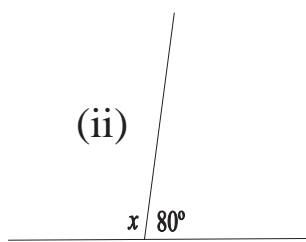
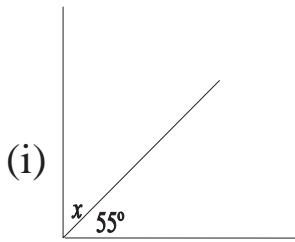

B

Faigh meán na ngrúpaí seo a leanas:

3, 8, 10

2, 3, 10

€5.50, €2.50, €1

12

A Scríobh na huimhreacha i ngach sraith thíos in ord méide. Tosaigh leis an uimhir is lú.

2.1, 1.9, 2.0, 2.4

0.8, 0.7, 1.6, 1.1

$2\frac{3}{5}$, 1.8, 2.5, $1\frac{7}{8}$

B Cé na suimeanna airgid atá á léiriú anseo thíos?

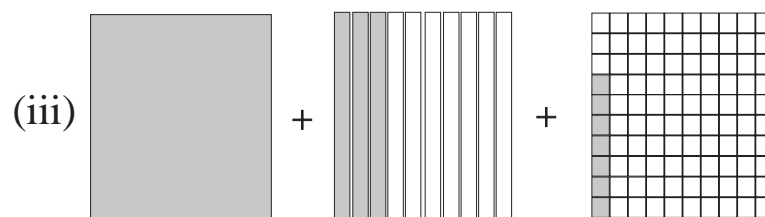
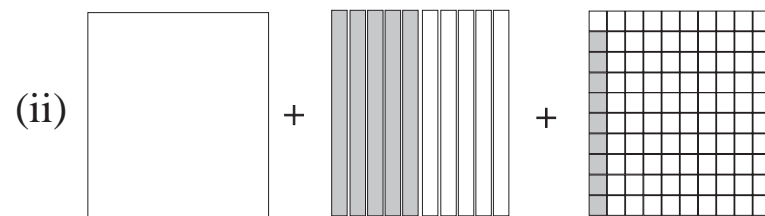
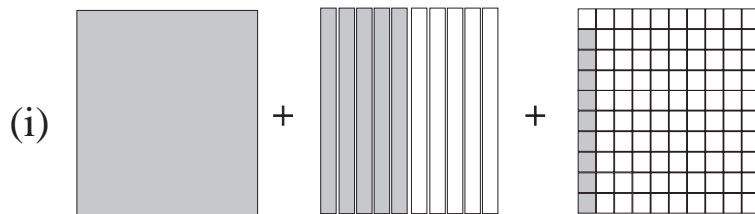

C Scríobh iad seo thíos ina ndeachúlacha.

$\frac{7}{100} =$

$\frac{21}{100} =$

$6 + \frac{1}{10} + \frac{3}{100} =$

$8 + \frac{4}{10} + \frac{6}{100} =$

Obair Gharbh

13

- (A) Líon isteach na chéad trí uimhir eile sa seicheamh thíos.

2.08, 2.09, _____, _____, _____

(B) 0.25 de $84 =$

(C) 0.2 de $40 =$

(D) $6.492 \times 100 =$

(E) $35.9 \div 100 =$

(F)

$\begin{array}{r} 9.66 \\ - 2.18 \\ \hline \end{array}$

Obair Gharbh

1

A Críochnaigh na cóimheasa seo a leanas.

$$15 : 50 = \square : 10$$

$$4 : 6 = \square : 12$$

B Scríobh na cóimheasa seo a leanas san fhoirm is simplí.

$$24 : 20 = \square : \square$$

$$25 : 100 = \square : \square$$

C Cad é cóimheas 150 m le 1 km?

D Cad é cóimheas 20 nóiméad le 1 uair an chloig?

E Cad é cóimheas 50 cent le €1.50?

F Cad é cóimheas 20 cm le 1 km?

Obair Gharbh

2

A Críochnaigh an tábla thíos.
(Líon isteach na bearnaí).

Obair Gharbh

Codán	=	Deachúil	=	Céatadán
$\frac{1}{10}$	=	0.1	=	10%
	=	0.125	=	12 $\frac{1}{2}$ %
	=	0.2	=	20%
$\frac{1}{4}$	=	0.25	=	25%
$\frac{3}{10}$	=	0.3	=	
$\frac{1}{3}$	=	0.333	=	
	=	0.375	=	37 $\frac{1}{2}$ %
$\frac{2}{5}$	=	0.4	=	40%
	=	0.5	=	50%
$\frac{3}{5}$	=	0.6	=	60%
	=	0.625	=	62 $\frac{1}{2}$ %
$\frac{2}{3}$	=	0.666	=	
$\frac{7}{10}$	=	0.7	=	
	=	0.75	=	75%
$\frac{4}{5}$	=	0.8	=	80%
	=	0.875	=	
$\frac{9}{10}$	=		=	90%
$\frac{10}{10}$	=	1	=	

3

(A) 25% de 120 =

(B) $66\frac{2}{3}\%$ de €58 =

(C) 96% de €2.75 =

(D) Méadaigh €546 50%

(E) Méadaigh €222 $33\frac{1}{3}\%$

(F) Laghdaigh €252 30%

(G) Laghdaigh €35 75%

(H) Scríobh ina ndeachúlacha:

35% =

4% =

1% =

Obair Gharbh

4

Marcáil aiseanna na siméadrachta ar na cruthanna seo.

A

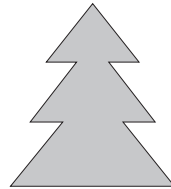
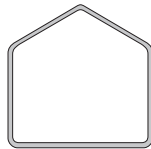
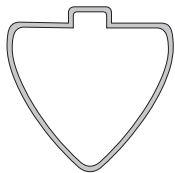

B

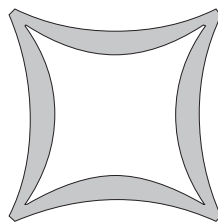
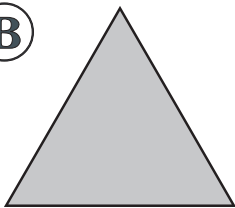

C

Críochnaigh an chéad chruth eile sna seichimh rothlacha seo.

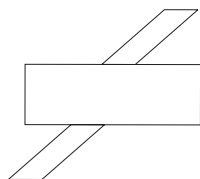
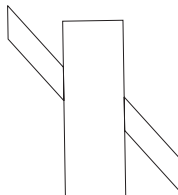
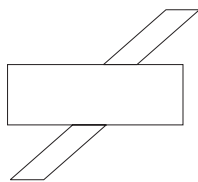
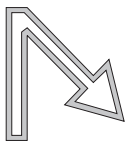
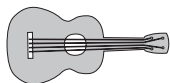

Obair Gharbh

5

Ⓐ $3^5 =$

Ⓑ $9^4 =$

<, > nó =

Ⓒ 100 10^3

Ⓓ 4^3 8^2

Ⓔ 2^6 3^5

Ⓕ 5^3 4^4

Uimhir agus séan atá ag teastáil sna freagraí ar cheisteanna **g**, **h**, agus **j**.

Ⓖ $2^4 \times 2^5 =$

Ⓗ $4 \times 4^2 \times 4^3 =$

$3^3 \times 3^6 =$

$3^2 \times 3^3 \times 3^4 =$

Ⓐ $(2 \cdot 4)^2 =$

Ⓙ $6^5 \div 6^3 =$

$(6 \cdot 2)^2 =$

$9^{10} \div 9^2 =$

Ⓚ Cad dó a sheasann **y** sa chothromóid seo a leanas?

$6,000 = 6 \times 10^y$

Obair Gharbh

6

A Scríobh na hamanna thíos sa chóras 24 uair an chloig.

1.30 a.m. =

9.32 p.m. =

2 a.m. =

11 a.m. =

10.30 p.m. =

3.15 p.m. =

6 p.m. =

6.15 a.m. =

B Scríobh na hamanna seo thíos sa chóras a.m. agus p.m.

05.45 =

14.00 =

13.00 =

21.00 =

07.10 =

18.34 =

05.04 =

12.55 =

C Cé mhéad uair agus nóiméad atá ann idir:

(i) 05.15 agus 05.45 ?

(ii) 08.23 agus 19.46 ?

(iii) 04.55 agus 08.15 ?

(iv) 10.39 agus 20.38 ?

D

uair	nóim.
4	30
+ 7	55
<hr/>	

E

uair	nóim.
8	22
- 2	49
<hr/>	

Obair Gharbh

7

Mí na Nollag

D	L	M	C	D	A	S
					1	2
3	4	5	6	7	8	9
10	11	12	13	14	15	16
17	18	19	20	21	22	23
24	25	26	27	28	29	30
31						

A Is é an dara Luan an lá déag de mhí na Nollag.

B Cén lá den t-seachtain ar a dtiteann Lá Nollag?

Baile Átha Cliath go Learpholl

Uimhir na hEitilte	Ag Imeacht	Ag Teacht Isteach
FR 660	07.10	07.55
FR 662	09.50	10.35
FR 664	13.20	14.05
FR 668	15.55	16.40

C Cén fad a ghlacann sé eitilt ó Bhaile Átha Cliath go Learpholl?

Obair Gharbh

8

A Ríomh méid na n-uillinneacha a go e.
Ná húsáid d'uillinntomhas.

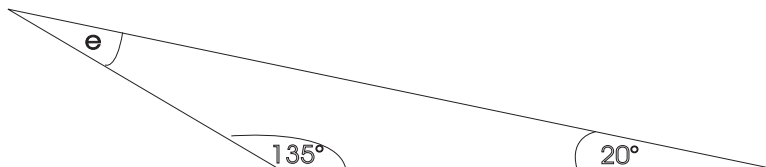
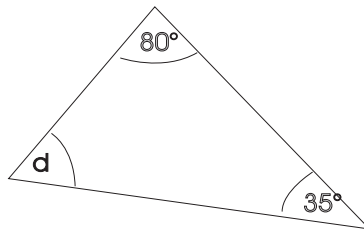
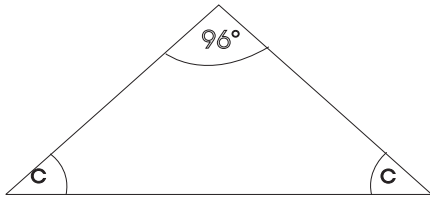
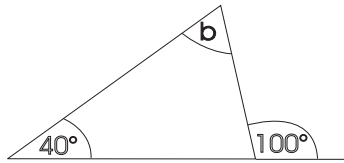
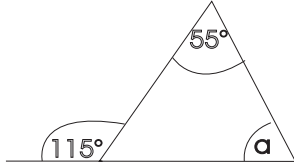

Obair Gharbh

9

(A) Críochnaigh an tábla

Trastomhas		17 cm		21 cm
Ga	$3\frac{1}{2}$ cm		$5\frac{2}{3}$ cm	

$$\pi = 3.14 \text{ nó } 3\frac{1}{7}$$

(B) Faigh imlíne rotha a bhfuil trastomhas 6 cm ann.

(C) 4.5 cm atá i nga ciorcail. Cad é fad na himlíne?

(D) 15.7 cm atá in imlíne ciorcail. Cén fad atá sa trastomhas?

(E) 19 cm atá in imlíne rotha. Cén fad a thaistealóidh an roth i 14 chasadh iomlána?

Obair Gharbh

10

A Cén fad atá sna línte seo dáiríre más é 1 cm : 10 cm an scála?



B Tá an plean seo sa scála 1 cm : 2 m. Cad é fíorachar an urláir ina mhéadair chearnacha?

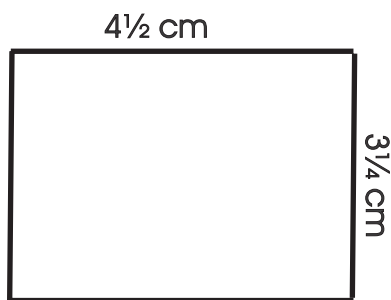

C Tarraingíodh an triantán seo sa scála 1 cm : 1 km. Cad é fad na himlíne sa léaráid? Cad é fíorfhad na himlíne?

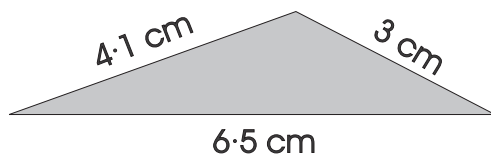

Obair Gharbh

11

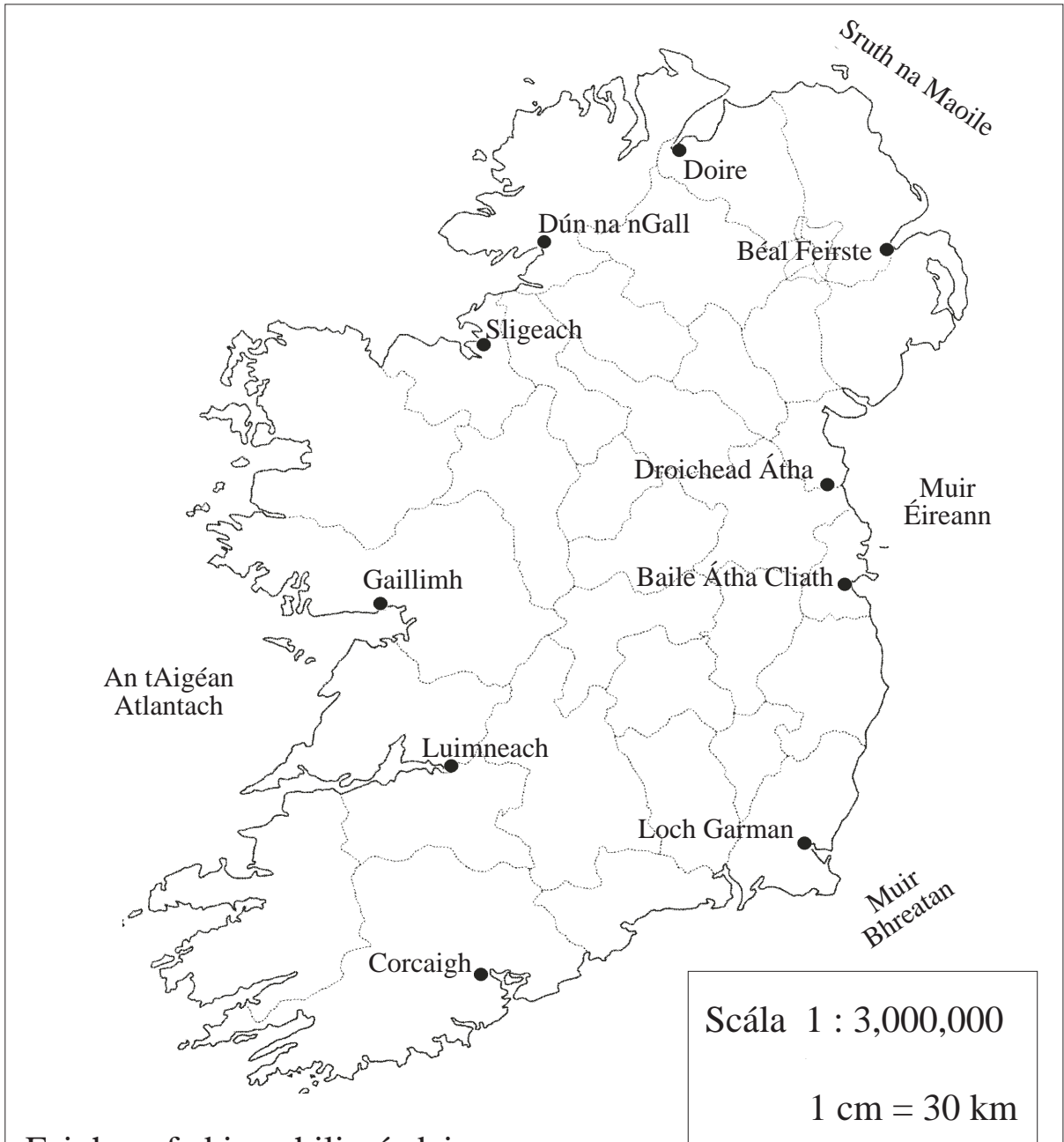

A Faigh an fad ina chiliméadair :

- (i) Ó Bhaile Átha Cliath go Dún na nGall km
- (ii) Ó Dhroichead Átha go Luimneach km
- (iii) Ó Luimneach go Loch Garman km
- (iv) Ó Chorcaigh go Baile Átha Cliath km
- (v) Ó Gaillimh go Droichead Átha km

Obair Gharbh

1

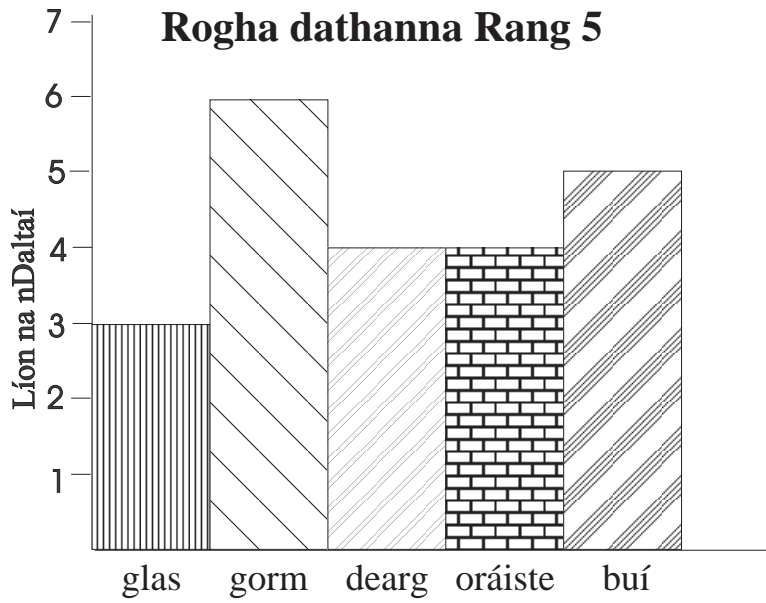

A

- (i) Cé mhéad dalta atá i Rang 5?
- (ii) Cén dath is mó a thaitníonn le daltaí rang 5?
- (iii) Cén dath is lú a thaitníonn leis na daltaí?
- (iv) Cé mhéad dalta arb é gorm a rogha?
- (v) Cé mhéad dalta arb é oráiste a rogha?
- (vi) Cé na dathanna a roghnaíodh os cionn an mheáin?
- (vii) Cé na dathanna a roghnaíodh faoi bhun an mheáin?

2

A

Rogha Ábhar Rang 5



Obair Gharbh

- (i) Cén t-ábhar is mó a thaitníonn leis na daltaí ?
- (ii) Cad iad na hábhair nach dtaitníonn leo chomh mór leis an nGaeilge?

B

Aoiseanna na bPáistí

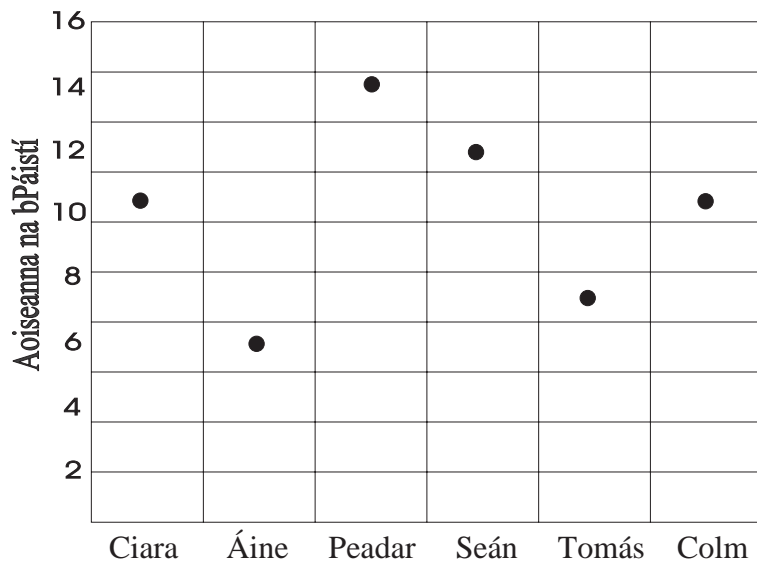

- (i) Cé acu is sine?
- (ii) Cé acu is óige?
- (iii) Cé mhéad bliain níos sine ná Áine atá an dara páiste is sine?
- (iv) Cad é aois na bpáistí ar meán?

3

€10 a bhí le caitheamh ag Tomás

A

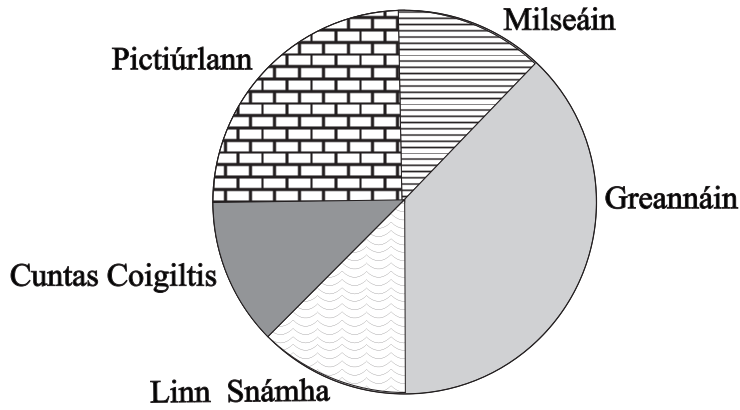

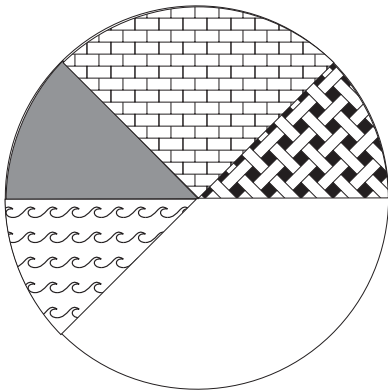

- (i) Cén méid airgid a chaith sé ar ghreannáin?
- (ii) Cén méid airgid a chaith sé sa linn snámha?
- (iii) Cén céatadán a chuir sé ina chuntas coigiltis?

B

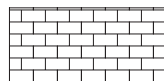

€100 atá á léiriú sa phíchart seo thíos. Cén méid airgid atá á léiriú i ngach teascóg ar leith?

 = €

 = €

 = €

 = €

 = €

4

Líon na nGluaisteán a bhí
Páirceáilte san Ionad Siopadóireachta

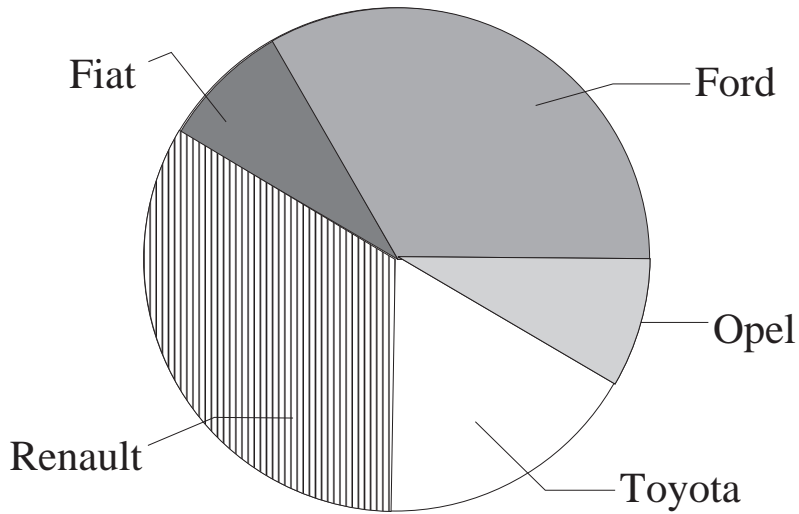

Obair Gharbh

A

Má bhí 360 gluaisteán sa charchlós

- (i) Cé mhéad Fiat a bhí ann?
- (ii) Cé mhéad Ford a bhí ann?
- (iii) Cén céatadán ar Renault iad?
- (iv) Cén céatadán ar Toyota iad?

5

A

Cé mhéad ceintiméadar atá i ngach ceann díobh seo a leanas?

(i) 0.21 m

(ii) 0.35 m

(iii) 2.86 m

B

Cé mhéad ceintiméadar atá i ngach ceann díobh seo a leanas?

(i) 4 m

(ii) $2\frac{3}{4}$ m

(iii) $\frac{3}{10}$ m

Obair Gharbh

C Scríobh iad seo a leanas ina gceintiméadair. Úsáid an pointe deachúlach.

(i) 65 mm

(ii) 7 mm

D

	cm	mm
	2	6
	2	7
+	1	5
	<hr/>	

	cm	mm
	4	5
-	1	6
	<hr/>	

E

	km	m
	2	290
	2	260
+	3	420
	<hr/>	

	km	m
	6	250
-	2	380
	<hr/>	

6

(A) Iompaigh ina ngram.

- (i) 1.85 kg (ii) 2.37 kg
 (iii) 3.275 kg (iv) 5.085 kg

(B) Iompaigh ina gcileagram

- (i) 2485 g (ii) 765 g
 (iii) 81 g (iv) 100 g

(C)

	kg	g
	3	248
	5	51
+	7	279

(D)

	kg	g
	2	49
	4	345
+	5	562

(E)

	kg	g
	6	658
-	4	439

(F)

	kg	g
	9	735
-	7	72

Bíodh do chuid freagraí ar cheisteanna **G-J** i bhfoirm kg.

(G)

(H)

(I)

(J)

Obair Gharbh

7

A

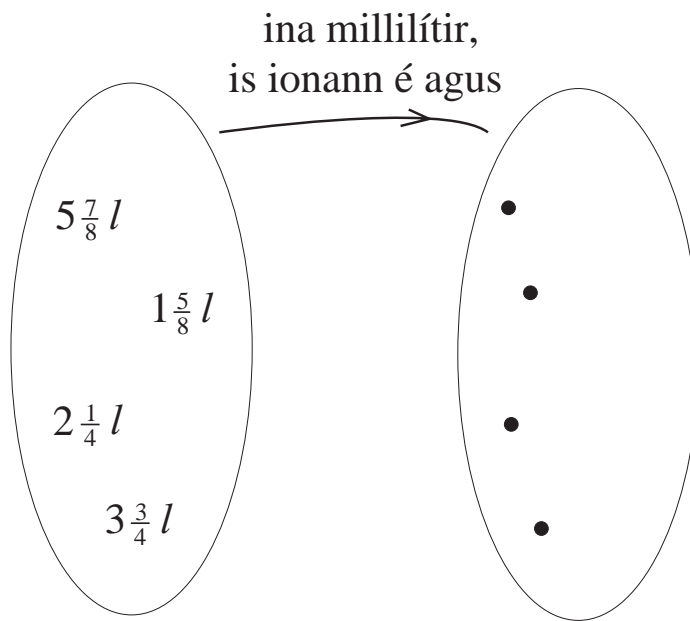

B

Iompaigh iad seo ina lítir.

(i) 100 ml =

(ii) 2000 ml =

C

(i) $3\text{ l } 315\text{ ml} + 8\text{ l } 17\text{ ml} + 12\text{ l} =$

(ii) $4\text{ l } 115\text{ ml} \times 6 =$

8

Meatseáil gach cruth leis an ainm ceart

Obair Gharbh

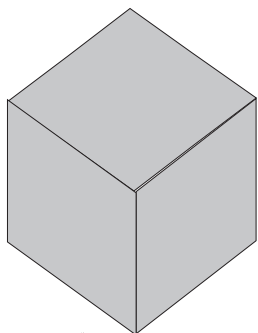

sféar

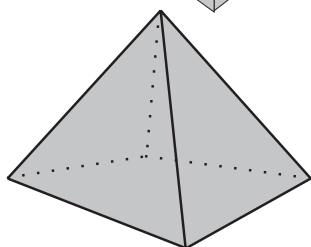

pirimid

priosma

ciúbóideach

ciúb

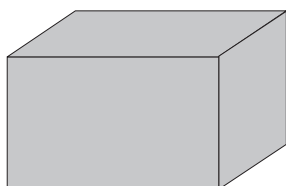

cón

sorcóir

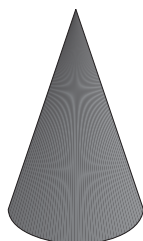
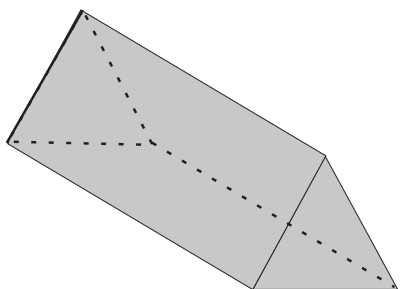

9

Faigh luach x.

- (A) $20 - x = 12$
- (B) $x + 7 = 18$
- (C) $8 \times x = 20 + 12$
- (D) $6 \times x = 36 \div 3$
- (E) $140 - x = 12 \times 10$
- (F) $7 \times x = 49$
- (G) $48 \div x = 144 \div 12$
- (H) $108 \div 9 = 132 \div x$
- (I) $36 + x = 9 \times 8$
- (J) $6 \times x = 50 + 10$
- (K) $12 \times x = 120 \div 12$
- (L) $100 + 131 = 11 \times x$

Obair Gharbh

10

Obair Gharbh

(A)

Taistealaíonn bus 89 km gach lá.
Cén fad a thaistealaíonn sé i 14 lá?

(B)

Tuilleann oibrí €253 sa tseachtain.
Cén fad ama a ghlacfadh sé air €13,156
a thuilleamh?

(C)

€56 an praghas ar cheamara. Laghdaíodh
an praghas 15% i sladmhargadh na Nollag.
Cén praghas a bhí air sa sladmhargadh?

(D)

Chaith bean $\frac{2}{5}$ dá cuid airgid san
ollmhargadh agus $\frac{1}{3}$ i siopa éadaí.
Má bhí €20 fágtha aici, cén méid a bhí aici
ar dtús?

(E)

Cé mhéad caipín snámha ar €3.15 an
ceann is féidir a cheannach le €37.80?

(F)

Má chaithim díse cén dóchúlacht atá
ann gur corruimhir a gheobhaidh mé?

Freagraí

Caibidil 1

Lch 1-1

1. Ré-uimhir. 2. Corruimhir 3. Corruimhir

Lch 1-3

1. $3 + 5 = 8$
2. Corruimhir + corruimhir = ré-uimhir
3. $11 + 9 = 20$
4. Corruimhir + corruimhir = ré-uimhir
5. $13 + 1 = 14$
6. Corruimhir + corruimhir + ré-uimhir

Lch 1-4

1. $4 + 6 = 10$
2. Ré-uimhir + ré-uimhir = ré-uimhir
3. $6 + 2 = 8$.
4. Ré-uimhir + ré-uimhir = ré-uimhir
5. $4 + 2 = 6$
6. Ré-uimhir + ré-uimhir = ré-uimhir .

Lch 1-5

3. $5 + 4 = 9$
4. Corruimhir + ré-uimhir = corruimhir
5. $7 + 6 = 13$.
6. Corruimhir + ré-uimhir = corruimhir

Lch 1-6

- a) 13, 16, 19
- b) 21, 25, 29
- c) 22, 19, 16
- d) $7\frac{1}{2}$, $9\frac{1}{2}$, $11\frac{1}{2}$
- e) 5 , $6\frac{1}{4}$, $7\frac{1}{2}$
- f) 100, 125, 150
- g) 8.5, 9.6, 10.7
- h) 32, 64, 128
- i) 12, 2, 15

Lch 1-7

1. $4 \times 8 = 22 + 10$
2. $(11 \times 9) - 8 = 91$

Lch 1-8

1. Corruimhir, ré-uimhir
2. 12, 18, 24, 30, 36, 42, 48, 54, 60, 66, 72
3. Ré-uimhreacha
4. Corruimhir, ré-uimhir
5. 8, 16, 24, 32, 40, 48, 56, 64, 72, 80, 88, 96
6. Ré-uimhreacha
7. 22, 24, 26, 28, 30, 32, 34, 36, 38
8. 5, 10, 15, 20, 25, 30, 35, 40, 45, 50, 55, 60, 65, 70, 75, 80, 85, 90, 95

Caibidil 2

Lch 2-1

1. 3 2. 4 3. 5 4. 3 5. 2 6. $2\frac{1}{2}$

Lch 2-2

- A. 40, 30, 60, 30, 70, 40, 30, 60
- B. 190, 140, 200, 240, 240, 480, 480, 360
- C. 1. 8 nó 9, 2. 7 3. 8 4. 10 nó 11
5. 3 6. 4 nó 5 7. 4 nó 5 8. 7 nó 8
- D. 1. 4 2. 5 3. 6 4. 8 5. 9 6. 12 7. 10 8. 14

Lch 2-3

22 an roinnteoir,
89 an inroinnt
4 an líon

Lch 2-4

1. 4 2. 2 3. 2 4. 3 5. 7 6. 3 7. 4 8. 4

Lch 2-5

1. 7 f 2 2. 3 f 4 3. 2 f 2 4. 2 f 2 5. 4 f 5 6. 4 f 5

Lch 2-6

1. 5 2. 4 f 16 3. 4 f 18 4. 3 f 1 5. 7 f 3 6. 5 f 11
7. 6 f 13 8. 3 f 3 9. 4 f 1 10. 3 f 1 11. 3 f 6 12. 4 f 13

Lch 2-8

1. 5 f 14 2. 6 f 15 3. 7 f 13 4. 8 5. 8 f 30
6. 9 f 19 7. 5 f 13 8. 8 f 2 9. 9 f 27 10. 9 f 16

Lch 2-9

1. 9 2. 7 3. €5.64 4. 6.5 5. 27 6. 23 7. 37

Caibidil 3

Lch 3-1

1. 15 2. 21

Lch 3-2

1.

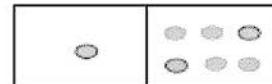

2. $36 \div 12 = 3$
3. $4 \times 9 = 20 + 16$
4. $5 \times 11 = 39 + 16$
5. $(3 \times 5) + 13 = 10 + 18$

Lch 3-4

1. 6, 8, 9, 10, 12

Caibidil 4

Lch 3-5

1. 21, 39, 51 2. 1, 15, 28 3. 17, 29, 31
 4. 25, 9, 16, 49 5. 27, 32, 35, 48 6. 25
 7. 2, 3, 5, 7, 11, 13, 17, 19, 23, 29, 31, 37, 41, 43, 47

Lch 3-7

1	2 0	3 0	4 x	5 0	6 x	7 0	8 x	9 x	10 x
11 0	12 x	13 0	14 x	15 x	16 x	17 0	18 x	19 0	20 x
21 x	22 x	23 0	24 x	25 x	26 x	27 x	28 x	29 0	30 x
31 0	32 x	33 x	34 x	35 x	36 x	37 0	38 x	39 x	40 x
41 0	42 x	43 0	44 x	45 x	46 x	47 0	48 x	49 x	50 x
51 x	52 x	53 0	54 x	55 x	56 x	57 x	58 x	59 0	60 x
61 0	62 x	63 x	64 x	65 x	66 x	67 0	68 x	69 x	70 x
71 0	72 x	73 0	74 x	75 x	76 x	77 x	78 x	79 0	80 x
81 x	82 x	83 0	84 x	85 x	86 x	87 x	88 x	89 0	90 x
91 x	92 x	93 x	94 x	95 x	96 x	97 0	98 x	99 x	100 x

Lch 3-8

1. 15, 20, 24, 28 2. 31

Lch 3-9

1. 7, 3 2. 25, 5, 5 3. 9, 3, 3 4. 3, 5

Lch 3-10

1. 6

Lch 3-11

1. 15 2. 24 3. 9 4. 17 5. 33

Lch 3-12

1. (a) Corruimhir 2. (b) 3. (c)

Lch 3-13

1. 3, 5, 7 2. 4, 6 3. Ré-uimhir 4. Corruimhir
 5. Ré-uimhir 6. Corruimhir 7. 2, 4, 6, 8, 0

Lch 3-15

1. (a) 35 (b) 24 (c) 72 (d) 72 (e) 60 (f) 60
 2. (a) 6 (b) 5 (c) 3 (d) 4 (e) 4

Lch 3-16

1. 3, 6, 9, 12, 15, 18, 21, 24, 27, 30, 30, 33, 36, 39,
 42, 45, 48, 51, 54, 57, 60, 63, 66, 69, 72, 75, 78,
 81, 84, 87, 90, 93, 96, 99
 2. 7, 14, 21, 28, 35, 42, 49, 56, 63, 70, 77, 84, 91, 98
 3. 21, 42, 63, 84
 4. 21

Lch 4-1

1. (a) $\frac{4}{6}$ nó $\frac{2}{3}$ (b) $\frac{1}{6}$ 2. (a) $\frac{3}{8}$ (b) $\frac{2}{8}$ nó $\frac{1}{4}$
 3. (a) $\frac{5}{8}$

Lch 4-4

1. 4, 6, 2, 1 2. 4, 3, 8, 8
 3. 6, 3, 6, 4 4. 3, 3, 1, 3
 5. (a) $\frac{3}{7}$, $\frac{3}{9}$, $\frac{3}{11}$, $\frac{5}{11}$ (b) $\frac{4}{7}$, $\frac{2}{3}$, $\frac{8}{11}$, $\frac{6}{11}$

Lch 4-5

1. (a) $\frac{2}{3}$ (b) $\frac{1}{2}$ (c) $\frac{3}{4}$ (d) $\frac{7}{8}$ (e) $\frac{9}{10}$
 2. 12 =>24, 27 =>54, 45=>90, 75=>150,
 50=>100, 122=>244
 3. 72, 48, 24

Lch 4-6

1. (a) 5 (b) 7 (c) $\frac{3}{8}$ (d) $\frac{5}{8}$ (e) $\frac{3}{4}$ (f) $\frac{7}{8}$
 (g) 6 (h) 2 (i) 2 (j) $\frac{1}{5}$ (k) $\frac{7}{10}$ (l) 4 (m) 8
 (n) 2 (o) 3 (p) 4 (q) 5 (r) 3

Lch 4-7

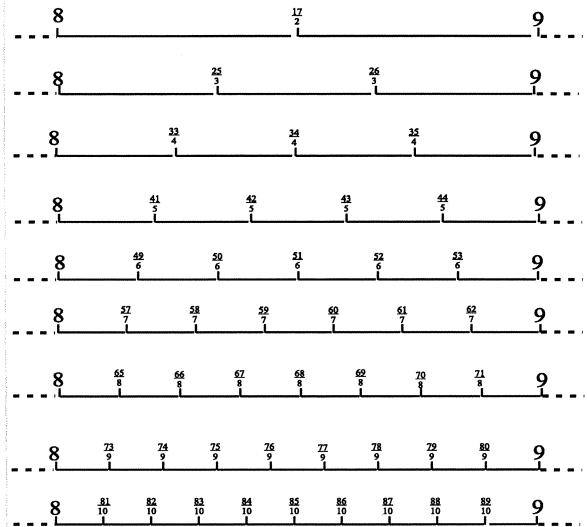

Lch 4-8

1. $\frac{5}{10}$ 2. $\frac{4}{10}$ 3. 8, 5 $\frac{5}{8}$ 4. $\frac{1}{3}$ 5. 36

Lch 4-12

1. (a) 1 (b) 3 (c) 6 (d) 2 (e) 1 (f) 3 (g) 2
 2. (a) 25 (b) 12 (c) 8 (d) 21 (e) 40 (f) 27 (g) 7

Freagraí *Leathanach 3*

Lch 4-13

1. $3\frac{1}{2}$, $4\frac{1}{8}$ 2. $\frac{3}{2}$, $\frac{10}{5}$, $\frac{6}{5}$
3. (a) $7\frac{13}{14}$ (b) $5\frac{5}{14}$ (c) $8\frac{7}{15}$ (d) $3\frac{5}{8}$ (e) $12\frac{4}{9}$

Lch 4-15

1. (a) $6\frac{11}{20}$ (b) $7\frac{5}{8}$ (c) $5\frac{1}{2}$ (d) $8\frac{7}{9}$ (e) $8\frac{7}{12}$
2. (a) $\frac{5}{6}$ (b) $2\frac{39}{40}$ (c) $2\frac{11}{12}$ (d) $2\frac{9}{10}$ (e) $1\frac{29}{40}$
3. (a) $1\frac{1}{3}$ (b) $6\frac{13}{20}$ (c) $2\frac{27}{28}$ (d) 10 (e) $8\frac{23}{24}$
4. (a) $2\frac{1}{8}$ (b) $1\frac{1}{8}$ (c) $3\frac{1}{8}$ (d) $3\frac{2}{3}$ (e) $9\frac{5}{12}$

Lch 4-16

1. (a) $\frac{15}{24}$ nó $\frac{5}{8}$ (b) $\frac{5}{20}$ nó $\frac{1}{4}$ (c) $\frac{35}{48}$
(d) $\frac{6}{20}$ nó $\frac{3}{10}$ (e) $\frac{6}{28}$ nó $\frac{3}{14}$
(f) $\frac{45}{80}$ nó $\frac{9}{16}$ (g) $\frac{11}{24}$ (h) $\frac{7}{40}$

Lch 4-17

1. (a) $9\frac{7}{20}$ (b) $19\frac{16}{27}$ (c) 4 (d) $26\frac{1}{4}$ (e) $13\frac{1}{54}$
2. (a) $1\frac{3}{4}$ (b) $3\frac{1}{8}$ (c) $3\frac{2}{5}$ (d) $4\frac{3}{8}$

Lch 4-18

1. $\frac{2}{5}$ 2. $2\frac{1}{4}$ 3. $\frac{3}{4}$ 4. $2\frac{1}{2}$ 5. $2\frac{2}{3}$

Lch 4-19

1. $\frac{2}{5}$ 2. $\frac{1}{2}$ 3. $\frac{1}{2}$ 4. $\frac{1}{8}$ 5. $\frac{1}{4}$ 6. $\frac{3}{8}$ 7. $\frac{1}{2}$ 8. $\frac{1}{4}$

Caibidil 5

Lch 5-1

- A. 11.5 cm^2 B. 19 cm^2 C. 30 cm^2 D. 14 cm^2
E. 31 cm^2

Lch 5-2

- A. 18 cm^2 B. 12 cm^2 C. 3 cm^2 D. 6 cm^2
E. 12 cm^2 F. 24 cm^2 G. 4 cm^2

Lch 5-3

- A. 24 cm^2 B. 42 cm^2 C. 25 cm^2 D. 14 cm^2
1. 84 cm^2 2. 108 cm^2 3. 55 cm^2 4. 110 cm^2
5. 63 cm^2 6. 48 cm^2 7. 32 cm^2 8. 42 cm^2
9. 45 cm^2 10. 16 cm^2

Lch 5-4

1. 169 2. 56 3. 225

Lch 5-5

- A. 5 cm^2 B. 5 cm^2 C. 6 cm^2 D. 5 cm^2 E. 5 cm^2
F. 11 cm^2 G. 6 cm^2

Lch 5-6

- A. 12 cm^2 B. 16 cm^2 C. 27 cm^2 D. $22\frac{1}{2} \text{ cm}^2$

Lch 5-7

1. (a) 12 (b) 15 (c) 3 (d) 8 (e) 12 (f) 11 (g) 9
(h) 9 (i) 2 (j) 12 (k) 9 (l) 77

Lch 5-8

1. 8 cm 2. 9 cm

Lch 5-9

1. (a) 16 cm (b) 37 cm (c) 18 cm (d) 37 cm
2. (a) 12 cm (b) 18 cm (c) 56 cm (d) 28 cm

Lch 5-10

1. 16 cm 2. 18 cm 3. 22 cm 4. 22 cm
5. 20 cm 6. 21 cm

Lch 5-11

- A. 12 cm B. 12 cm C. 14 cm D. 12 cm
E. 12 cm F. 12 cm G. 24 cm

Lch 5-12

1. 18 m 2. imlíne, 40 m 3. C

Lch 5-13

1. (a) 450 m^2 (b) 3 huaire, 45 nóiméad
2. 36 cm^2 3. 32 cm 4. (iii) 5. 13.2 m 6. €432

Lch 5-14

1. 6 2. 11 3. 6 4. 5 5. 2 6. 7 7. 3 8. 8 9. 4

Lch 5-15

1. (a) 15 cm^2 2. 405 cm^2

Lch 5-16

1. AB = 14 cm, AD = 4 cm
Achar = 56 cm^2 Imlíne = 36 cm
2. (a) 4.76 cm^2 (b) 9 cm
3. (a) 58.8 m^2 (b) 36.4 m

Lch 5-17

1. 16.5 cm 2. 15 cm 3. 33.8 4. 28 cm 5. 6 cm

Lch 5-19

1. 32 cm^2 2. 72 cm^2

Lch 5-20

1. 24 cm^2 2. 42.5 cm^2 3. 42.5 cm^2 4. 1800 cm^2

Lch 5-21

1. 378 cm^2 2. 144 cm^2 3. 80 cm^2

Caibidil 6

Lch 6-1

1. (a) 2 (b) 9 2. 8 3. 6

Lch 6-2

1. 18 2. cothrománach 3. ceartingearach

Lch 6-3

1. 6 2. Níl 3. 2, 3 4. Líne chothrománach
5.

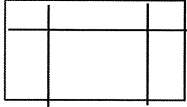

Lch 6-5

1. chothrománach 2. cheartingearach

Lch 6-7

3. Cearnóg 4. (i) 6 (ii) 24

Lch 6-9

1. 3 2. 12

Lch 6-10

1. 1

Lch 6-11

1. 1 2. 3

Lch 6-12

1. 4 2. Maoluillinn 3. Géaruillinn

Lch 6-13

1. Dronuillinn 2. Géaruillinn 3. Géaruillinn
4. Uillinn dhíreach 5. Maoluillinn
6. Uillinn athfhillteach

Lch 6-14

1. 40° 2. 130° 3. 40° 4. 130° 5. 120° 6. 245°
7. 45° 8. 45° 9. Níl.

Lch 6-15

- (b) dronuillinn (c) maoluillinn (d) uillinn dhíreach
(e) maoluillinn (f) maoluillinn (g) géaruillinn
(h) dronuillinn (i) géaruillinn

Lch 6-16

1. 90° 2. 30° 3. 300° 4. 270°

Lch 6-17

1. 30° 2. 110° 3. 50° 4. 40° 5. 130° 6. 250°

Lch 6-18

1. 70° 2. 110° 3. 110° 4. 90° 5. 105° 6. 45° 7. 20°
8. 170°

Lch 6-19

1. 340° 2. 225° 3. 135° 4. 65° 5. 325° 6. 250°

Lch 6-21

1. (a) Soir ó dheas (b) Siar ó thuaidh (c) Siar
(d) Soir (e) Siar ó dheas (f) Soir
2. (a) Siar ó thuaidh (b) Soir ó dheas (c) Ó dheas
(d) Ó thuaidh (e) Siar ó dheas (f) Ó thuaidh

3.

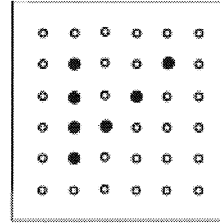

Caibidil 7

Lch 7-2

1. (a) 5 (b) 5 (c) 7 (d) 9 (e) 50
2. (a) 3 (b) €9.50 (c) 2 (d) €3

Lch 7-3

1. 1 m 39 cm 2. 5 leabhar
3. 5½ bliain (cúig bliana go leith) 4. 5 chúl

Lch 7-4

1. 225 g 2. 30 3. 106 kg 4. €163,000
5. 74 lítear 6. 3 cm

Caibidil 8

Lch 8-1

2. 0.6 3. 0.8

Lch 8-2

1. (b) 1.4 (c) 2.2 (d) 3.3 (e) 1.5 (f) 2.7 (g) 1.9
(h) 4.3 (i) 7.7 (j) 5.9
2. 4.2 3. 4.6

Lch 8-3

1. $\frac{3}{10}$, $\frac{4}{10}$, $\frac{5}{10}$, $\frac{6}{10}$, $\frac{7}{10}$, $\frac{8}{10}$, $\frac{9}{10}$
0.4, 0.5, 0.6, 0.7, 0.8, 0.9
2. A. 0.3 B. 0.1 C. 0.9 D. 0.8 E. 0.7 F. 0.2
G. 0.4 H. 0.5 I. 0.6 J. 10 cent K. 50 cent
L. 40 cent M. 70 cent N. 100 cent O. 160 cent
P. 40 cent

Lch 8-4

1.

C	D	A	$\frac{1}{10}$	C	D	A	$\frac{1}{10}$
*	*	*	*	*	*	*	*
*	*	*	*	*	*	*	*
*	*	*	*	*	*	*	*
*	*	*	*	*	*	*	*
*	*	*	*	*	*	*	*
*	*	*	*	*	*	*	*
*	*	*	*	*	*	*	*
*	*	*	*	*	*	*	*

2. A. 0.9, 1.2, 1.6, 2.1
 B. 0.5, 2.1, 4.8, 5.0
 C. 1.2, 1.5, $1\frac{6}{10}$, 1.7
 D. 4.9, 7.6, 8.0, 9.3
 E. 1.8, 3.5, 4.9, 6.2
 F. 0.8, $1\frac{6}{10}$, 1.7, 1.9

Lch 8-6

1. B. $\frac{8}{10}$ C. 6 aonad D. trí chéad
 E. 2 aonad F. dhá dheich (fiche)
 2. €0.60, €0.40, 0, €0.10, €0.01, €0.10
 3. €0.07, €0.26, €0.09, €0.06, €0.15, €0.72
 4. B. €0.15 C. €2.15 D. €1.80 E. €1.50
 F. €1.00 G. €1.90 H. €0.75 I. €4.35 J. €1.90

Lch 8-7

1. A. 34 B. 98 C. 62 D. 73 E. 25 F. 84 G. 16
 H. 38 I. 45 J. 59
 (a) €0.31 (b) €0.82 (c) €0.71 (d) €0.55

Lch 8-9

1. €1.33 2. €1.59 3. €1.94 4. €1.44

Lch 8-10

1. €0.32 2. €1.09 3. €0.90 4. €0.03

Lch 8-11

2. 1.57 3. 1.07 4. 0.2

Lch 8-13

1. B. 0.04 C. 0.39 D. 0.21 E. 0.06 F. 0.65
 G. 0.59 H. 0.19 I. 0.49 J. 0.84
 2. A. 2.46 B. 9.13 C. 3.31 D. 6.12 E. 4.23
 F. 7.38 G. 8.56 H. 41.49 I. 62.22 J. 97.97
 K. 84.81 L. 45.94 M. 63.75 N. 11.11

Lch 8-14

1. Deirdre 29.57, Colm 29.68, Sorcha 29.86
 2. Sorcha
 3. Úna 61, Tadhg 61.36, Diarmaid 61.41

Lch 8-15

- A. 2.41, 2.43, 2.45 B. 6.58, 6.60, 6.62
 C. 1.26, 1.28, 1.30 D. 5.35, 5.37, 5.39
 E. 13.68, 13.70, 13.72 F. 12.90, 12.94, 12.98
 G. 3.62, 3.65, 3.68 H. 4.10, 4.11, 4.12
 I. 13.27, 13.37, 13.47 J. 6.40, 6.43, 6.46

Lch 8-16

1. $\frac{2}{3}$ de 51 2. $\frac{1}{3}$ de 75
 3. $\frac{2}{5}$ de 40 4. 0.9 de 55
 5. 0.25 de 84

Lch 8-17

1. 3.47 2. 3.88 3. 5.16 4. 7.23 5. 6.53
 6. 6.48 7. 10.02 8. 10.80 9. 13.50 10. 12.20
 11. 8.21 12. 6.42 13. 5.23 14. 3.04 15. 6.46
 16. 6.29 17. 6.48 18. 6.72 19. 4.58 20. 1.90
 21. 1.00 22. 0.93 23. 2.99 24. 3.60 25. 1.22

Lch 8-18

1. Diarmaid, Dara, Deirdre, Sorcha, Colm
 2. Sorcha, Colm, Dara, Deirdre, Diarmaid
 3. Colm, Dara, Sorcha, Deirdre, Diarmaid

Lch 8-19

1. 0.2, 0.7, 0.5

Lch 8-20

1. B. 6 C. 5 D. 8 E. 9 F. 7

Lch 8-21

1. B. 0.06 C. 0.04 D. 0.05 E. 0.03 G. 0.01
 H. 0.09 I. 0.08
 2. B. 6.2 C. 7.4 D. 35.6 E. 46.3 G. 24.6
 H. 3.3 I. 17.6 J. 91.4
 3. B. 0.17 C. 0.047, D. 0.626 E. 0.308
 G. 0.3 H. 0.006 I. 0.206 J. 0.1

Lch 8-22

1.

2.2 + 2.0	2.8 + 1.0	2.6 + 2.7	0.5 x 10
1.3 + 0.1	1.2 + 0.5	1.3 + 1.6	1.3 + 2.2
4.0 + 1.6	4.0 + 0.1	2.7 + 0.5	2.8 + 2.0
4.0 x 2.25	4.0 x 0.5	2.0 + 1.4	2.6 + 1.3

Lch 8-23

1. (a) 13.5 (b) 3.45 (c) 247 (d) 623.8 (e) 430.6
 2. (a) 1.56 (b) 0.66 (c) 0.007 (d) 0.372 (e) 0.002

Freagraí Leathanach 6

Lch 8-24

1. 1.6, 3.9, 4.2 2. $\frac{2}{10} + \frac{5}{100}$
 3. €24.50 4. 0.75 5. 20 6. €24.50
 7. (a) 0.75 (b) 0.25 8. 2.7 9. €25 10. 20

Lch 8-25

1. €5.40 2. 94 3. 76 4. 631.66
 5. 210 km 6. 607.94

Caibidil 9

Lch 9-2

1. (a) 6:3 (b) 4:7 (c) 7:4 (d) 4:6 (e) 3:7 (f) 4:3

Lch 9-3

1. (a) 1:4 (b) 1:3 (c) 5:4 (d) 1:3 (e) 1:3
 2. (a) 2:1 (b) 6:5 (c) 5:3 (d) 6:1 (e) 5:1

Lch 9-4

1. (a) 1:4 (b) 5:3 (c) 4:3 (d) 3:2 (e) 1:3 (f) 1:2

Lch 9-5

1. 360 kg
 2. $\frac{1}{2}$, 1, 2, 6
 3. (a) 900 (b) 2, 6

Lch 9-6

1. (a) 3:8 (b) 1:3 (c) 6:5 (d) 1:3 (e) 3:2
 2. (a) 1:4 (b) 1:4 (c) 4:1 (d) 1:6 (e) 5:4
 3. (a) €0.75, €1.25 (b) 40 nóiméad, 50 nóiméad
 (c) 800 g, 200 g (d) €32, €24 (e) €16, €24
 (f) 70 cent, 50 cent (g) 1 m 25 cm, 75 cm
 (h) 15 nóiméad, 45 nóiméad, (i) €40, €160
 (j) €16, €8

Lch 9-7

1. (a) 3:7 (b) €1650, €3850
 2. €48, €12 3. €99 4. €5.40 €6.25

Caibidil 10

Lch 10-2

1. 9% 2. 87% 3. 51%

Lch 10-3

1. 65% 70% 99%
 2. 60% 30% 1%
 3. 66% 34% 5%
 4. 43% 69% 100%

Lch 10-4

1. (b) 0.17 (c) 0.02 (d) 0.25 (e) 0.2
 2. (a) 0.8 (b) 0.08 (c) 0.18 (d) 0.09 (e) 0.9

Lch 10-5

1. (b) 17% (c) 2% (d) 25% (e) 20%
 2. (a) 80% (b) 8% (c) 18% (d) 9% (e) 90%

Lch 10-6

1. (a) 20% (b) 30% (c) 80% (d) 25%
 (e) 60% (f) 70% (g) 50% (h) 90%
 2. (a) 30 (b) 66 (c) 54 (d) 93 (e) 21 (f) 2
 (g) 9 (h) 45

Lch 10-7

1. 0.09 nó 9% 2. 0.87 nó 87%
 3. 0.51 nó 51%

Lch 10-8

1. (a) 0.08 (b) 0.15 (c) 0.35 (d) 0.24
 (e) 0.9 (f) 0.05 (g) 0.09 (h) 0.11
 2. (a) 3% (b) 8% (c) 1% (d) 32% (e) 87%
 (f) 19% (g) 74% (h) 2%

Lch 10-9

1. (a) €145.80 (b) €43 (c) €117.60 (d) €9
 2. (a) €495 (b) €158 (c) €608 (d) €493

Lch 10-10

1. (a) 25% (b) $12\frac{1}{2}$ (c) 0.3% (d) 80% (e) 2%
 (f) 20% (g) 8% (h) 30%
 2. $\frac{5}{8}$ 3. $\frac{3}{8}$

Lch 10-12

Codán		$\frac{1}{8}$	$\frac{1}{5}$		$\frac{3}{10}$	$\frac{3}{8}$
Deachúil	0.1		0.2	0.25		0.375
Céatadán	10%	$12\frac{1}{2}$ %		25%	30%	

Codán		$\frac{1}{2}$	$\frac{3}{5}$		$\frac{5}{8}$
Deachúil	0.4		0.6	0.333	
Céatadán	40%	50%		$33\frac{1}{3}$ %	$62\frac{1}{2}$ %

Codán		$\frac{7}{10}$	$\frac{3}{4}$		$\frac{7}{8}$
Deachúil	0.66		0.75	0.8	
Céatadán	$66\frac{2}{3}$ %	70%		80%	$87\frac{1}{2}$ %

Lch 10-13

- €102.60, €15.30, €196.65, €96.84, €52.83, €4.32,
 €22.68

Lch 10-14

2. B 3. B 4. B 5. B 6. B 7. B 8. A 9. B 10. B

Lch 10-15

1. 84%, 88%, 70%, 60%

Freagraí *Leathanach 7*

Lch 10-16

1. 70% 90% 64% 60% 90%

Lch 10-17

1. 40 % de €50, €2 2. €33, 333 3. 155,000 l
4. (a) 162 (b) 378 (c) 70% 5. 741

Lch 10-18

1. 408 2. €13, 305
3.

42	558	93%
12	588	98%
9	591	98½%
18	582	97%
30	570	95%

4. 60 kg 5. €160

Lch 10-19

1. €3 2. (a) 60 % (b) 90
3. 40 úll, 20 banana, 32 pluma
4. 420 5. €45, €27, €18

Lch 10-20

1. €30 2. 2.8 m 3. €1.50 4. 80.5 kg
5. 4.25 kg 6. 15.6 kg 7. €1.80

Caibidil 11

Lch 11-1

1. Iad ar fad seachas 8, 9 agus 12.

Lch 11-3

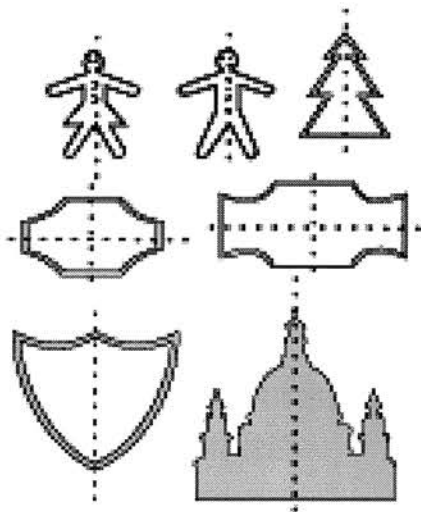

Lch 11-4

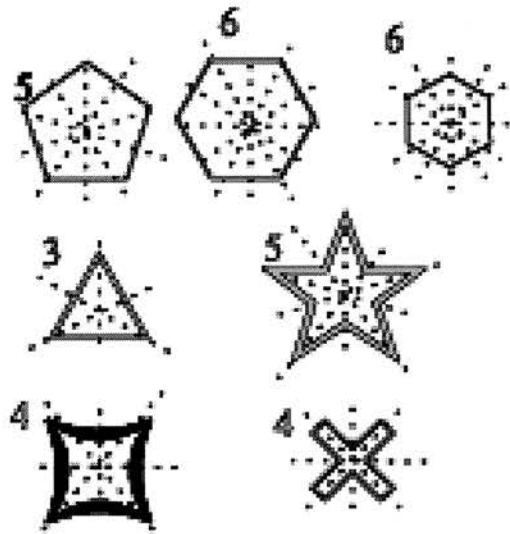

Lch 11-6

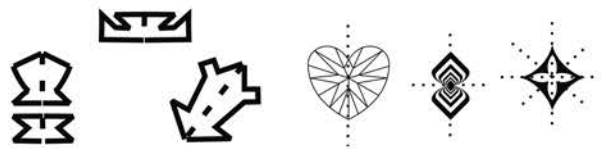

Lch 11-7



Lch 11-8

1.



Lch 11-9

1.



Lch 11-10

1. (B) 180° (C) 90° (D) 120° (E) 180° (H) 180°
2. Ceathrú tar éis a deich.
3. A hocht a chlog.

Caibidil 12

Lch 12-1

1. toradh, chomhionanna
toradh, chomhionanna
8, 27, 64

Lch 12-2

1. $4 \times 4 \times 4 = 64$
2. $5 \times 5 \times 5 \times 5 = 625$
3. $4 \times 4 \times 4 \times 4 \times 4 = 1024$

Lch 12-3

1. (a) 7^4 (b) 9^7 (c) 3^8 (d) 8^2 (e) a^3 (f) b^3 (g) c^4
2. 5^3 , 3^4 , 4^5
3. 4.41, 12.96, 3.61 4. 0.001, 0.125

Lch 12-4

1. (a) 100 (b) 6561 (c) 7776 (d) 1024 (e) 49
(f) 32768 (g) 4096 (h) 2187 (i) 5764801
2. (a) $>$ (b) $<$ (c) $<$ (d) $>$ (e) $<$ (f) $>$
3. (a) 4096, $>$ (b) 343, $>$ (c) 3125, $>$ (d) 216, $>$
(e) 256, $>$ (f) 64, $>$

Lch 12-6

1. (a) 3^7 (b) 6^{10} (c) 2^9 (d) 10^4 (e) 8^8 (f) 9^5 (g) 7^5
(h) 5^5 (i) 4^{11}
2. (a) 100, 16, 625, 243 (b) 1000, 49, 4096, 729
(c) 10.24, 18.49, 26.01, 56.25

Lch 12-7

1. 16.1524 2. 9 3. 3^3 4. $x = 3$ 5. 48
6. (a) 500 (b) 700 (c) 9000 (d) 320 (e) 1210

Lch 12-9

1. (a) 4^2 (b) 5^3 (c) 3^5 (d) 10^3 (e) 9^5 (f) 7^1 (g) 6^2
(h) 8^3 (i) 5^4 (j) 2^1

Lch 12-10

1. (a) 10^1 (b) 7^2 (c) 8^4 (d) 6^2 (e) 8^7
2. (a) $x = 13^2 = 169$ (b) $x = 18^2 = 324$
(c) $x = 19^3 = 6859$ (d) $x = 73,800$

Caibidil 13

Lch 13-1

2. 12.50 3. 7.40 4. 9.10 5. 3.15
6. 3.30 7. 6.45 8. 3.05 9. 12.25
10. 8.55

Lch 13-2

1. 11.50, 06.55, 03.05, 11.30, 16.10

Lch 13-3

1. (a) Uair agus 20 nóiméad (b) 2 uair
(c) 2 uair agus 10 nóiméad
(d) 2 uair agus 35 nóiméad
(e) 3 uair agus 10 nóiméad
2. (a) 50 (b) 20 (c) 40 (d) 45 (e) 30

Lch 13-4

1. (a) 9 n-uair agus 5 nóiméad
(b) 9 n-uair agus 55 nóiméad
(c) 11 uair
(d) 10 n-uair agus 25 nóiméad
(e) 8 n-uair agus 25 nóiméad
2. (a) 4 uair agus 50 nóiméad
(b) 11 uair agus 20 nóiméad
(c) 8 n-uair agus 5 nóiméad
(d) 11 uair agus 25 nóiméad
(e) 10 n-uair agus 55 nóiméad

Lch 13-6

1. 12.50, 07.55, 12.25, 05.00, 04.15,
03.05, 06.40, 10.55, 06.10

Lch 13-7

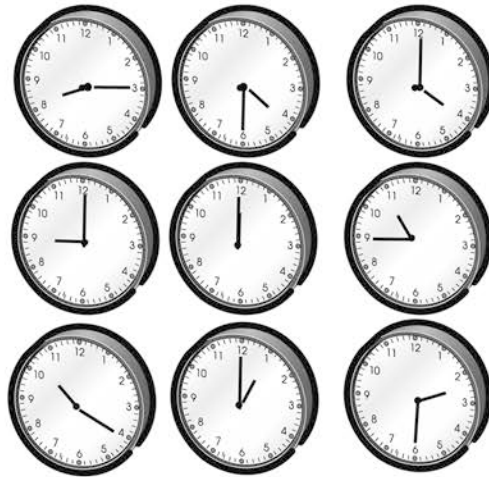

Lch 13-8

1. (a) 13.20 (b) 19.30 (c) 09.00 (d) 10.00 (e) 08.30
(f) 00.08 (g) 12.45 (h) 11.10 (i) 04.40
2. (a) 8.00 p.m. (b) 1.50 a.m. (c) 4.45 p.m.
(d) 12.25 p.m. (e) 10.15 a.m. (f) 2.10 p.m.
(g) 1.00 p.m. (h) 12.07 a.m. (i) 6.30 p.m.

3. (i) 1 uair agus 15 nóiméad (ii) 15.40 (iii) FR113

Lch 13-9

1. 9 n-uair agus 20 nóiméad
2. 5 uair 13 nóiméad
3. 6 huaire agus 14 nóiméad
4. 3 huaire agus 36 nóiméad
5. 8 n-uair agus 12 nóiméad
6. 6 huaire agus 31 nóiméad

Lch 13-10

1. (a) 2 uair agus 15 nóiméad
(b) 2 uair agus 15 nóiméad
(c) Uair agus 40 nóiméad
(d) 3 huaire agus 15 nóiméad
(e) 2 uair agus 35 nóiméad
(f) 2 uair agus 40 nóiméad

3. (a) 9.30 a.m. (b) 1.15 p.m. (c) 2.30 p.m.
(d) 5.20 p.m. (e) 10.15 p.m. (f) 3.40 p.m.

Lch 13-11

1. Uair agus 40 nóiméad
2. 2 uair agus 52 nóiméad
3. 2 uair agus 41 nóiméad
4. 2 uair agus 40 nóiméad
5. Uair agus 29 nóiméad
6. 5 huaire agus 43 nóiméad
7. 3 huaire agus 37 nóiméad
8. 2 uair agus 50 nóiméad
9. 5 huaire agus 31 nóiméad

Lch 13-12

1. (a) 6 huaire agus 15 nóiméad
(b) 6 huaire agus 38 nóiméad
(c) 12 uair agus 29 nóiméad
(d) 9 n-uaire agus 45 nóiméad

Lch 13-12

1. Páras: 02.45, 06.15, 12.30, 08.25
Perth: 09.45, 13.15, 19.30, 15.25
Caireo: 03.45, 07.15, 13.30, 09.25
Shanghai: 09.45, 13.15, 19.30, 15.25
Tóiceo: 10.45, 14.15, 20.30, 16.25
Moscó: 04.45, 08.15, 14.30, 10.25

Lch 13-14

1. Montréal: 20.45, 00.15, 06.30, 02.25
Chicago: 19.45, 23.15, 05.30, 01.25
Los Angeles: 17.45, 21.15, 03.30, 23.25
Honolulu: 15.45, 19.15, 01.30, 21.25
Meicsiceo: 19.45, 23.15, 05.30, 01.25
Nua-Eabhrac: 20.45, 00.15, 06.30, 02.25

Lch 13-15

1. 4 2. 4 3. 4 4. 5

Lch 13-16

1. 13 Deireadh Fómhair 2. Dé hAoine
3. 24 Deireadh Fómhair
4. Eanáir, Márta, Bealtaine, Iúil, Lúnasa,
Deireadh Fómhair, Mí na Nollag.

Lch 13-17

1. 24 Nollaig, (Oíche Nollag) 2. 7, 14, 21, 28
3. 15 bliana agus 3 mhí 4. 2 Nollaig

Lch 13-18

1. (a) 55 nóiméad (b) 45 nóiméad (c) 2 uair go leith

Lch 13-19

1. (a) Uair agus 25 nóiméad (b) 45 nóiméad
(c) 55 nóiméad (d) Uair agus 15 nóiméad
(e) 50 nóiméad

Lch 13-20

1. 144 km san uair
2. 4 huaire agus 51 nóiméad
3. 3 huaire agus 19 nóiméad
4. 5 huaire agus 35 nóiméad
5. 07.25, 07.35, 07.45, 07.55, 08.05
6. 105 ciliméadar
7. 142.5 ciliméadar
8. 28 uair agus 45 nóiméad
9. 175 ciliméadar
10. (a) 13 huaire agus 25 nóiméad
(b) 10 n-uaire agus 35 nóiméad

Caibidil 14

Lch 14-1

1. (a) 186.59 (b) 223.44 (c) 204.58 (d) 738.36

Lch 14-2

1. (a) 0.5658 (b) 7.2364 (c) 2.0148 (d) 3.4704
(e) 1.4265 (f) 4.7276 (g) 1.7612 (h) 2.5912
(i) 3.4773 (j) 0.9396
2. (a) 3.596 (b) 28.073 (c) 17.712 (d) 14.212
(e) 41.976 (f) 9.765 (g) 27.504 (h) 11.868
(i) 71.949 (j) 6.578

Lch 14-4

1. (a) 11.9 (b) 16.6 (c) 12.9 (d) 4.44
2. (a) 4 (b) 38.4 (c) 34.6 (d) 13.3 (e) 75.2 (f) 69.1

Lch 14-5

1. (a) 12.4 (b) 13 (c) 71.2 (d) 23.7

Caibidil 15

Lch 15-1

1. A, B

Lch 15-2

- Triantán: 3, 3 Ceathairshleasán : 4, 4
Comhthreomharán: 4, 4 Dronuilleog: 4, 4
Cearnóg: 4, 4 Peinteagán: 5, 5
Heicseagán: 6, 6 Heipteagán: 7, 7
Ochtagán: 8, 8 Nónagán: 9, 9
Deacagán: 10, 10

Lch 15-3

	✓	✓	✓
	✓	✓	✓
	✓	X	✓
	X	X	X
	✓	X	X
	X	X	X
	✓	X	X

Lch 15-4

10	13	19	22

- Ní féidir
- 1 + 3 + 3 + 3

Lch 15-7

a = 75° b = 32° c = 55° d = 75° e = 62°

Lch 15-8

1.

Nónagán	Heicseagán
Heipteagán	Peinteagán
Ochtagán	Deacagán

Lch 15-11

- (a) 2 (b) 5 (c) 3 (d) 1 (e) 4 (f) 2

Caibidil 16

Lch 16-2

- 10 cm

Lch 16-3

1. 16 cm 2. 4.5 cm

Lch 16-4

1.

	5 cm		31 cm		
12.5 cm		21 cm		15 cm	50 cm

Lch 16-7

- 4 cm

2.

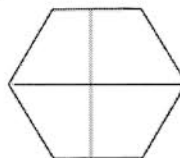

3.

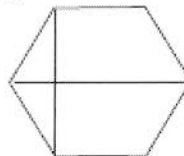

Caibidil 17

Lch 17-1

- (a) 64 m (b) 56 m (c) 52 m (d) 76 m (e) 48 m

Lch 17-2

1.

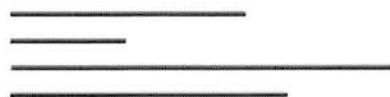

- (a) 4 m (b) 6.4 m (c) 4.8 m (d) 4.8 m (e) 4.8 m

Lch 17-4

- An Phríomhshráid
- 10 m 3. 85 m 4. 30 m
- 200 m² 6. 6 theach

Lch 17-5

1.

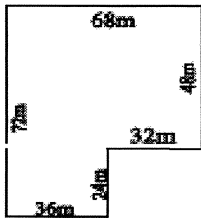

Achar = 36 m x 72 m + 32 m x 48 m
= 4128 m²

Lch 17-6

1. (a) 190 km (b) 75 km (c) 220 km (d) 140 km

Caibidil 18

Lch 18-1

1. 12 2. 2 3. Toyota 4. Fiat 5. 42

Lch 18-3

1. 145 lítear 2. 36.25 lítear
3. Muintir Uí Néill 4. 13.75 lítear
5. Muintir Uí Riain 6. 20%

Lch 18-4

1. Méid an airgid phóca a fuair na páistí
2. Líon na bpáistí 3. Seisear 4. Naonúr
5. Ceithre pháiste is fiche

Lch 18-5

1. (a) $\frac{1}{4}$ (b) $\frac{1}{9}$
2. (a) $\frac{1}{2}$ (b) $\frac{1}{4}$ (c) $\frac{1}{9}$ (an naoú cuid)

Lch 18-6

1. (a) 4 (ceathrar) (b) Donn (c) 16 (sé pháiste dhéag)
(d) $12\frac{1}{2}\%$
2. (a) $\frac{1}{3}$ (trian) (b) $\frac{1}{6}$ (an séú cuid) (c) $\frac{1}{2}$ (a leath)
3. (a) 4 (ceathrar) (b) 8 (ochtar)
(c) 16 (sé dhuine dhéag)

Lch 18-7

1. 10 mbliana
2.

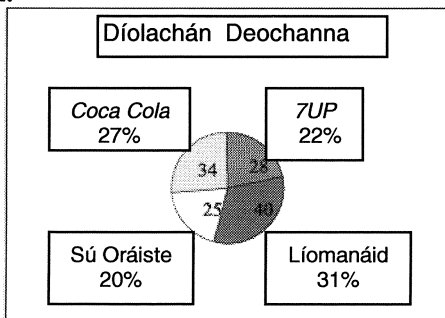

Lch 18-10

1. (a) $\frac{1}{15}$ (b) $\frac{1}{3}$ (c) $\frac{1}{4}$
2. (a) $\frac{1}{12}$ (b) $\frac{1}{8}$ (c) $\frac{1}{6}$

Lch 18-11

1. A. 60° $\frac{1}{6}$ B. 40° $\frac{1}{9}$ C. 80° $\frac{2}{9}$
D. 30° $\frac{1}{12}$ E. 45° $\frac{1}{8}$ F. 105° $\frac{7}{24}$
2. A. 120° $\frac{1}{3}$ B. 60° $\frac{1}{6}$ C. 50° $\frac{5}{36}$
D. 40° $\frac{1}{9}$ E. 90° $\frac{1}{4}$

Lch 18-12

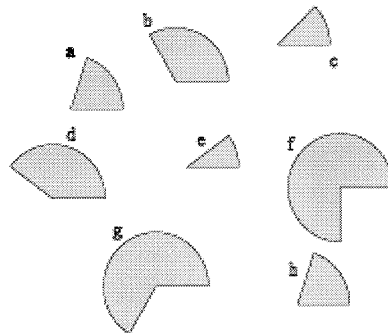

2. 25 3. 18 4. 100

Lch 18-13

1. Modhanna taistil chun na scoile

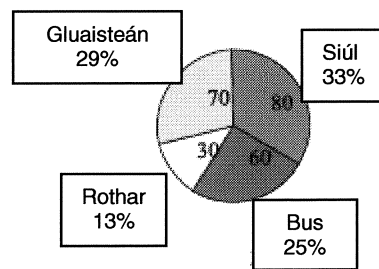

2. (a) 20 (b) 250

Caibidil 19

Lch 19-1

1. (a) 200 cm (b) 250 cm (c) 600 cm (d) 50 cm
(e) 75 cm (f) 25 cm
2. (a) 20 cm (b) 10 cm (c) 30 cm (d) 550 cm
(e) 40 cm (f) 380 cm

Lch 19-2

- (a) 420 cm (b) 950 cm (c) 182 cm (d) 403 cm
- (a) 5160 cm (b) 2390 cm (c) 50 cm (d) 25 cm
- (a) 300 cm (b) 25 cm (c) 100 cm (d) 75 cm
(e) 150 cm (f) 200 cm (g) 50 cm (h) 400 cm
(i) 225 cm (j) 175 cm (k) 10 cm (l) 90 cm
- (a) 14 (b) 96 (c) 132 (d) 476 (e) 156 (f) 203
(g) 82 (h) 341 (i) 2 (j) 77 (k) 209 (l) 168
- 2.19 m 8.94 m

Lch 19-3

- 16 mm 2. 2 mm 3. 9 mm

Lch 19-4

- (a) 2.6 cm (b) 4.1 cm (c) 3.3 cm (d) 5.5 cm
(e) 8.2 cm (f) 6.4 cm (g) 9.6 cm (h) 7.8 cm
(i) 10.9 cm (j) 1.3 cm
- (a) 1.9 cm (b) 0.4 cm (c) 0.2 cm (d) 0.5 cm
(e) 0.6 cm (f) 0.3 cm (g) 0.8 cm (h) 0.7 cm
(i) 1.0 cm (j) 0.9 cm

Lch 19-5

- (a) 85.1 cm (b) 49.7 cm (c) 96.1 cm
(d) 37.7 cm (e) 6.6 cm
- (a) 61.4 cm (b) 73.1 (c) 28.2 cm
(d) 49.2 cm (e) 95.3 cm

Lch 19-6

- 6 cm 8 mm 2. 6.8 cm 3. 2 cm 9 mm 4. 2.9 cm
5. 5 m 483 mm 6. 18.m 503 mm 7. 5 m 864 mm
8. 5 m 985 mm

Lch 19-7

- (a) 10.28 m (b) 10.58 m (c) 10.912 m
(d) 12.23 m (e) 10.806 m (f) 12.01 m
- (a) 1 m 88 cm (b) 4 m 93 cm (c) 2 m 648 mm
(d) 1 m 628 mm (e) 6 m 255 mm (f) 3 m 52 cm

Lch 19-8

- (a) 9.503 m (b) 5.31 m (c) 13.098 m
(d) 11.69 m (e) 10.794 m (f) 1.749 m (g) 3.85 m

Lch 19-9

- (a) 6 mhéadar (b) €29.10 2. €3.80 3. €24.67
- 8 5. 1.966 m, 2.034 m 6. 2.69 7. 285

Lch 19-10

- 4000 m, 7000 m, 10 000 m
- 500 m, 4500 m, 8500 m,
- 2100 m, (b) 5400 m (c) 3750 m (d) 7250 m
- ($6\frac{1}{2}$ km, 6500 m), ($5\frac{1}{4}$ km, 5250 m),
(.75 km, 750 m), (4.5 km, 4500 m),
(8.5 km, 8500 m).
- ($10\frac{3}{4}$ km, 10 750 m), ($9\frac{1}{10}$ km, 9100 m),
($5\frac{1}{5}$ km, 5200 m), ($11\frac{3}{10}$ km, 11 300 m),
($6\frac{4}{5}$ km, 6800 m)

Lch 19-11

- €4.13 2. 112.5 km 3. 9 n-uaire 4. 8.785 km
5. 19.286 km 6. 12 km 588 m 7. 264 m
8. 181 km 830 m 9. 165 m 10. 73.116 km

Caibidil 20

Lch 20-1

- (a) 1680 g (b) 7350 g (c) 4450 g (d) 4045 g
(e) 1360 g (f) 4670 g
- (a) 1010 g (b) 3500 g (c) 7230 g (d) 5025 g
(e) 1679 g (f) 6000 g

Lch 20-2

- (a) 1.348 (b) 0.036 (c) 0.728 (d) 8.462
(e) 0.009 (f) 0.097
- (a) 0.228 (b) 0.078 (c) 0.345 (d) 0.08
(e) 3.72 (f) 0.1
- (a) 9.729 kg (b) 10.2 kg (c) 8.229 kg
(d) 11.46 kg (e) 6.221 kg

Lch 20-3

- (a) 50 kg (b) 4.25 kg 2. 4.55 kg 3. 50.855 kg
4. 126.kg 585 g 5. 7

Caibidil 21

Lch 21-1

- Cartán bainne (aon lítear amháin),
Buidéal uisce mianraí (750 ml),
Buidéal linbh (333 ml), Canna sóide (280 ml)
Cupán caife (250 ml), Canna péint (2.5 lítear)

Lch 21-2

- 10 2. 3 3. Ní líonfadh.
- (a) 1300 ml (b) 10 000 ml (c) 3500 ml
(d) 12 500 ml (e) 1250 ml (f) 2750 ml
5. 5 l (5000 ml), $4\frac{1}{4}$ l (4250 ml), $7\frac{1}{2}$ l (7500 ml),
 $8\frac{1}{2}$ l (8500 ml), $6\frac{3}{4}$ l (6750 ml)
6. 2 l 300 ml (2300 ml), 9 l 700 ml (9700 ml)
3 l 130 ml (3130 ml), 1 l 900 ml (1900 ml)

Lch 21-3

- 5250 ml, 4600 ml, 7019 ml, 3750 ml
- 5800 ml, 2009 ml, 3079 ml, 4125 ml, 3625 ml
- 7875 ml, 5500 ml, 6875 ml, 8600 ml

Lch 21-4

- 1 l 250 ml, 6 l 800 ml, 3 l 450 ml, 19 l 873 ml
- 2 l 200 ml, 1 l 760 ml, 24 l 500 ml, 7 l 600 ml
- 700 ml, 175 ml, 250 ml, 1 l 400 ml

Lch 21-5

- (a) 18 l 475 ml (b) 16 l 406 ml (c) 16 l 406 ml (d) 18 l 370 ml
- (a) 3 l 647 ml (b) 5 l 387 ml (c) 6 l 763 ml (d) 14 l 931 ml
- (a) 7 l 22 ml (b) 5 l 655 ml (c) 3 l 405 ml (d) 5 l 453 ml

Lch 21-6

- 250 ml
- €32.55
- (a) 821.25 l (b) €10.08
- 252
- €8.64

Caibidil 22

Lch 22-1

- A, F, G, H

Lch 22-2

-

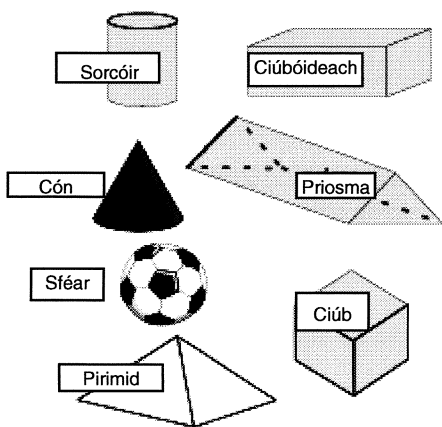

Caibidil 23

Lch 23-1

- (a) 8 (b) 11 (c) 4 (d) 2 (e) 20 (f) 7 (g) 4 (h) 11 (i) 36 (j) 10 (k) $\frac{5}{6}$ (l) 12

Lch 23-2

- (a) $x = 11$ (b) $a = 15$ (c) $b = 23$ (d) $x = 43$ (e) $y = 43$ (f) $x = 18$
- (a) $x = 13$ (b) $x = 4$ (c) $x = 3$ (d) $x = \frac{1}{2}$ (e) $x = 8$
- (a) $x = 1.925$ (b) $y = 3.5$ (c) $a = 30$ (d) $a = 33$ (e) $x = 15$

Caibidil 24

Lch 24-3

- $\frac{1}{6}, \frac{1}{6}, \frac{1}{6}$ 2. $\frac{1}{8}, \frac{1}{8}, \frac{1}{8}$
- Corruimhir. $\frac{2}{5}$ nó 40%. $\frac{3}{5}$ nó 60%.

Lch 24-5

- $\frac{1}{4}$ nó 25%
- 1 as 6
- $\frac{1}{250}$ Ní dócha é in aon chor.
- $\frac{1}{52}$ 5. $\frac{2}{6}$ nó $\frac{1}{3}$ 6. $\frac{3}{6}$ nó $\frac{1}{2}$

Lch 24-6

- $\frac{1}{26}$ 2. 5 3. $\frac{5}{26}$ 4. 21 5. $\frac{21}{26}$ 6. Consan.
- An dóchúlacht chéanna sa dá chás.
- $\frac{10}{25}$ nó 40%

Triail 1

- (a) 12, 480 (b) 6,617 (c) 5,975 (d) 61.36 (e) 106.01 (f) 382.2 (g) 332.7 (h) 14,272.44 (i) 5,635.4 (j) 1,926.4
- (a) 162 (b) 197.6 (c) 197.1 (d) 670.8 (e) 45.54 (f) 25.175 (g) 35.1282 (h) 41.7908 (i) 3,142.8 (j) 4,887
- (a) 13.2 (b) 2.799 (c) 0.896 (d) 6 (e) 8 (f) 0.044 (g) 0.076 (h) 31 (i) 17 (j) 890
- (a) corruimhir, corruimhir, corruimhir, ré-uimhir (b) ré-uimhir (c) corruimhir (d) $6\frac{3}{4}, 8\frac{1}{4}, 9\frac{3}{4}$ (e) 8.7, 9.9, 11.1 (f) 7, 11 (g) 1, 3, 6, 10 (h) fíor, fíor

- (a) 3 (b) 168 (c) 4 (d) 5 (e) 3 (f) 2 (g) 6 (h) 3 (i) $\frac{1}{8}$ (j) 5

6. (a)

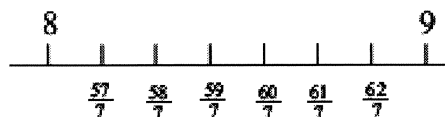

- (b) $\frac{1}{3}$ (c) 1 (d) 8 (e) $3\frac{1}{4}, 4\frac{1}{7}$ (f) $\frac{3}{2}, \frac{10}{5}, \frac{6}{5}$
- (a) $5\frac{5}{12}$ (b) $6\frac{8}{15}$ (c) $3\frac{7}{16}$ (d) $9\frac{5}{12}$ (e) 39 (f) $4\frac{3}{8}$ (g) $11\frac{2}{3}$ (h) 46 (i) 98 (j) 28
- (a) (i) $\frac{1}{3}$ (ii) $\frac{5}{16}$ (iii) $\frac{1}{8}$ (b) 24 cm² (c) 4 m (d) 28 cm

9. (a) 12 cm^2
 (b) (i) ceartingearach (ii) cothrománach
 (iii) comhthreomhar (iv) ceartingearach
 (v) cothrománach (vi) comhthreomhar

10. (a)

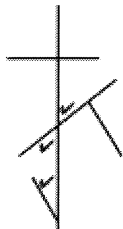

- (b) (i) géaruillinn (ii) uillinn dhíreach
 (iii) dronuillinn (iv) uillinn athfhillteach
 (v) maoluillinn (vi) géaruillinn
 (c) (i) 335° (ii) 145°
11. (a) (i) 35° (ii) 100° (iii) 105° (iv) 100°
 (v) 120° (vi) 60° (vii) 35° (viii) 175°
 (b) 7, 5, €3

12. (a) 1.9, 2.0, 2.1, 2.4; 0.7, 0.8, 1.1, 1.6;
 $1\frac{7}{8}$, 1.8, 2.5, $2\frac{3}{5}$
 (b) (i) €1.59 (ii) €0.59 (iii) €1.37
 (c) 0.07, 0.21, 6.13, 8.46

13. (a) 2.10, 2.11, 2.12 (b) 21 (c) 8 (d) 649.2
 (e) 0.359 (f) 7.48

Triail 2

1. (a) 3,8 (b) 6 : 5, 5 : 20 (c) 3 : 20 (d) 1 : 3
 (e) 1 : 3 (f) 1 : 5,000
2. (a) $\frac{1}{8}$, $\frac{1}{5}$, 30%, $33\frac{1}{3}\%$, $\frac{3}{8}$, $\frac{1}{2}$, $\frac{5}{8}$,
 $66\frac{2}{3}\%$, 70%, $\frac{3}{4}$, $\frac{7}{8}$, $87\frac{1}{2}\%$,
 0.9, 100%
3. (a) 30 (b) .39c (c) €2.64 (d) €819 (e) €294
 (f) €176.40 (g) €8.75 (h) 0.35, 0.04

4. (a)

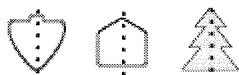

(b)



(c)

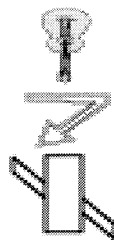

5. (a) 243 (b) 6,561 (c) < (d) = (e) < (f) <
 (g) 2^9 nó 512, 39 nó 19,683
 (h) 4^6 nó 4,096, 3^9 nó 19,683
 (i) 5.76, 38.44
 (j) 6^2 nó 36, 9^8 nó 43,046, 721
 (k) 3
6. (a) 01.30, 21.32, 02.00, 11.00, 22.30, 15.15,
 18.00, 06.15
 (b) 5.45 a.m. 2.00 p.m. 1.00 p.m. 9.00 p.m.
 7.10 a.m. 6.34 p.m. 5.04 a.m. 12.55 p.m.
 (c) (i) 30 nóiméad (ii) 11 uair 23 nóiméad
 (iii) 3 huaire 20 nóiméad
 (iv) 9 n-uair 59 nóiméad
 (d) 12 uair 25 nóiméad
 (e) 5 huaire 33 nóiméad
7. (a) An t-aonú lá déag (b) Dé Luain
 (c) 45 nóiméad

8. $a = 60^\circ$, $b = 60^\circ$, $c = 42^\circ$, $d = 65^\circ$, $e = 25^\circ$

9. (a) 7 cm, 8.5 cm, $11\frac{1}{3}$ cm, 10.5 cm
 (b) 18.8 cm (c) 28.3 cm (d) 5 cm (e) 266 cm
10. (a) 40 cm, 29 cm (b) 58.5 cm^2
 (c) 13.6 cm, 13.6 cm
11. (i) 210 km (ii) 210 km (iii) 165 km
 (iv) 240 km (v) 207 km

Triail 3

1. (a) (i) 22 (ii) gorm (iii) glas (iv) 6 (seisear)
 (v) 4 (ceathrar) (vi) gorm agus buí
 (vii) glas, dearg agus oráiste
2. (a) (i) Mata/Gaeilge
 (ii) Béarla, Tíreolaíocht, Corpoideachas
 (b) (i) Peadar (ii) Áine (iii) sé bliana (iv) 10
3. (a) (i) €3.75 (ii) €1.25 (iii) $\frac{1}{8}$
 (b) €25, €12.50, €12.50, €12.50, €37.50

Freagraí *Leathanach 15*

4. (a) (i) 30 (ii) 120 (iii) $\frac{1}{3}$ (iv) $\frac{1}{6}$

5. (a) (i) 21 (ii) 35 (iii) 286

(b) (i) 400 (ii) 275 (iii) 30

(c) (i) 6.5 cm (ii) 0.7 cm

(d) 6 cm 8 mm, 2 cm 9 mm

(e) 7 km 970 m, 3 km 870 m

6. (a) (i) 1850 g (ii) 2370 g (iii) 3275 g (iv) 5085 g

(b) (i) 2.485 kg (ii) 0.765 kg (iii) 0.081 kg

(iv) 0.1 kg

(c) (i) 15 kg 578 g (d) 11 kg 956 g (e) 2 kg 219 g

(f) 2 kg 663 g (g) 24.05 kg (h) 1.464 kg

(i) 1.813 kg (j) 17.575 km

7. (a) $5\frac{7}{8}$ l = 5875 ml, $1\frac{5}{8}$ l = 1625 ml,

$2\frac{1}{4}$ l = 2250 ml, $3\frac{3}{4}$ l = 3750 ml

(b) (i) 0.1 l (ii) 2 l

(c) (i) 23 l 332 ml (ii) 24 l 690 ml

9. (a) 8 (b) 11 (c) 4 (d) 2 (e) 20

(f) 7 (g) 4 (h) 11 (i) 36 (j) 10 (k) $\frac{5}{6}$

10. (a) 1,246 km (b) 52 seachtain (c) €472.60

(d) €75 (e) 12 (f) $\frac{3}{6}$

8.

